

Tumble dryer

T5290

Features and benefits

- Axial airflow and tight construction gives low energy consumption
- High productivity - 2 full loads per hour
- Large door opening for easy loading and unloading
- Easy and ergonomic access to the lint screen
- Excellent water evaporation efficiency per kWh
- The coin version with Ecopower to avoid over drying of the garments and get a lower energy consumption
- With Compass Pro program control
 - Large and clear display with control knob for easy program selection
 - Easy access with userfriendly interface
 - Language selection
 - Drying program packages optimized on Economy, Care and Time
 - Service program for adjustment of parameters
 - USB connection

Main options

- Stainless steel front
- Stainless steel drum
- Residual Moisture Control - RMC
- Payment systems: coin meter with Ecopower, central payment, chip card, intelligent communication
- Reversing drum
- Heat recovery system: Heat Recovery Pipes (HRP)
- Fresh air intake
- Emergency stop button
- Supply disconnecter
- Exhaust on top
- Frequency controlled motor



Images shown are a representation of the product only and variations may occur.

Main specifications			T5290				
Rated capacity,	filling factor 1:18	kg/lb	16.1/35.5				
	filling factor 1:22	kg/lb	13.2/29.1				
Drum volume		litre	290				
Drum diameter		mm	680				
Heating alternatives	electric	kW	13.5/18				
	gas	BTU/h (kW)	71 700 (21)				
	steam at 600-700 kPa		kW	25			
Consumption data*			13.5 kW	18 kW	Gas	Steam	
Total time at 13.2 kg		min	27	21	20	23	
Energy consumption at 13.2 kg		kWh	6.32	6.15	7.13	10.29	
Evaporation		g/min	244	303	328	293	
Energy kWh/litre water evaporated		kWh/l	0.96	0.97	1.06	1.56	

* At rated capacity 100% cotton load at 50% initial moisture dried to 0%.

Electrical connections		T5290	
Heating Voltage			
El.	400-415V 3N AC 50/60 Hz	kW(A)	14.5 (25)
	400-415V 3N AC 50/60 Hz	kW(A)	18.9 (35)
	440-480V 3AC 60 Hz	kW(A)	14.5 (20)
	440-480V 3AC 60 Hz	kW(A)	19.0 (35)
	230-240V 3AC 50/60 Hz	kW(A)	19.0 (50)
	230-240V 3AC 50/60 Hz	kW(A)	14.5 (50)
	230-240V 1AC 50/60 Hz	kW(A)	14.3 (63)
	230-240V 1AC 50/60 Hz	kW(A)	18.8 (100)
Gas/ steam	400-415V 3N AC 50/60 Hz	kW(A)	1.0 (10)
	440-480V 3AC 60 Hz	kW(A)	1.0 (10)
	230-240V 3AC 50/60 Hz	kW(A)	1.0 (10)
	230-240V 1AC 50/60 Hz	kW(A)	1.0 (10)
Steam, gas and air connections			
Steam	ISO 7/1-R		1"
Steam pressure		kPa	100-1000
Steam consumption		kg/h	65
Condensate	ISO 7/1-R		1"
Gas	NG/PG	ISO 7/1-R	1/2"
Gas pressure	Natural gas	Pa	2000
		mbar	20
	Propane	Pa	2800-3700
		mbar	28-37
Air outlet		ø mm	200
Evacuated air* el 13 kW		m ³ /h	380
	el 18 kW	m ³ /h	450
steam			640
	gas		550
Pressure drop (el 13 kW/el 18 kW)	Max. Pa		350/400
			350/350
Sound levels			
Airborne sound level		dB(A)	<70
Heat emission			
% of installed power, max			15
Shipping data (el/steam/gas)			
Shipping volume	net, kg		220
	crated, kg		235
	boxed, kg		330
Shipping volume	crated, m ³		1.72
Accessories			
Heat recovery pipes			HRP290
Fresh air intake			x
Dimensions in mm			
A	Width		710
B(a)	Depth		1155
B(b)	Depth		1335
C	Height		1675
D			725
E			780
F			140
G			1310
H			70
I			155
J			1380
K			55
L			355
M			685
N			605
1	Control panel	5	Exhaust connection
2	Door opening ø 580 mm	6	Condensate connection
3	Electrical connection	7	Steam connection
4	Gas connection	8	Lint screen

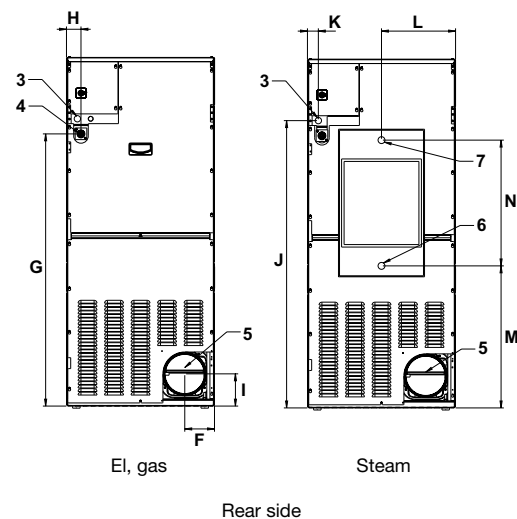
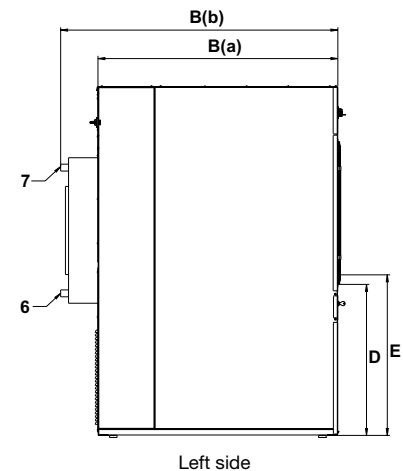
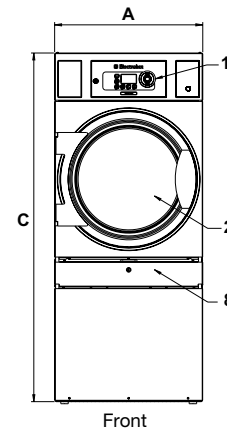

* Consumed air when the machine is optimally installed. Filling factor 1:22 when machine is warm.