



TRUE EUROPE

Field's End Road, Goldthorpe, Nr. Rotherham, South Yorkshire S63 9EU, England • www.truemfg.com • Tel 01709 888 080 • Fax 01709 880 838
• Free Phone 0 800 783 2049 • Free Phone to U.S. 0 800 894 928

Project Name: _____

Location: _____

Item #: _____ Qty: _____

Model #: _____

A/A #

SIS #

Model:
TGU-2

Gastronorm Undercounter:
Solid Door Refrigerator



TGU-2

- ▶ True undercounter units are designed with enduring quality that protects your long term investment.
- ▶ Designed using the highest quality materials and components to provide the user with colder product temperatures, lower utility costs, exceptional food safety and the best value in today's food service marketplace.
- ▶ Oversized, environmentally friendly (134A) force-air refrigeration system holds .5°C to 3.3°C (33°F to 38°F).
- ▶ Stainless steel exterior front, top and ends. Matching aluminum finished back.
- ▶ Radius countertop.
- ▶ Stainless steel interior and door liners.
- ▶ LED temperature display.
- ▶ Front breathing.
- ▶ 3 sets of ¼gastronorm rails with stainless steel shelves per door section.
- ▶ Foamed-in-place using Ecomate. A new, innovative, high density, polyurethane insulation that has zero ozone depletion potential (ODP) and zero global warming potential (GWP).

ADVANCED TECHNOLOGY
Reverse Condensing Fan Motor



Reversing Air Flow Keeps Your Condenser Clean!*

* Manufacturer recommended condenser cleaning every 2-3 months. Please consult your technical/installation manual for proper cleaning instructions.

Radius Countertop



ROUGH-IN DATA

Specifications subject to change without notice.

Chart dimensions rounded up to the next whole millimeter (inches rounded up to the next 1/8").

Model	Doors	Capacity (liters)	Shelves	Cabinet Dimensions (mm)			HP	Voltage	Amps	NEMA Config.	Cord Length (total m)	Crated Weight (kg)
				L	D	H						
TGU-2	2	297	6	1420	712	864	1/3	230-240/50/1	2.3	▲	2.74	157

▲ Plug type varies by country.

	APPROVALS:	AVAILABLE AT:
Printed in U.S.A.		

Model:
TGU-2

Gastronorm Undercounter: Solid Door Refrigerator



STANDARD FEATURES

DESIGN

- True's commitment to using the highest quality materials and oversized refrigeration systems provides the user with colder product temperatures, lower utility costs, exceptional food safety and the best value in today's food service marketplace.

REFRIGERATION SYSTEM

- Factory engineered, self-contained, capillary tube system using environmentally friendly (CFC free) 134A refrigerant.
- Reversing Condenser Fan Motor keeps the condenser cleaner, reducing wear and stress on the compressor, and decreasing service calls significantly.
- Oversized, factory balanced, refrigeration system with guided airflow to provide uniform product temperature.
- Extra large evaporator coil balanced with higher horsepower compressor and large condenser; maintains cabinet temperature of .5°C to 3.3°C (33°F to 38°F) for the best in food preservation.
- Sealed, cast iron, self-lubricating evaporator fan motors and larger fan blades give True undercounter units a more efficient low velocity, high volume airflow design. This unique design ensures faster temperature recovery and shorter run times in the busiest of food service environments.

CABINET CONSTRUCTION

- Exterior - stainless steel front, top and ends. Matching aluminum finished back.
- Interior - stainless steel interior and door liners.
- Insulation - entire cabinet structure and solid doors are foamed-in-place using Ecomate. A new, innovative, high density, polyurethane insulation that has zero ozone depletion potential (ODP) and zero global warming potential (GWP).
- 102 mm (4") diameter stem castors - locks provided on front set. 864 mm (34") work surface height.

DOORS

- Stainless steel fronts and liners.
- Each door fitted with 305 mm (12") long recessed handle that is foamed-in-place with a sheet metal interlock to ensure permanent attachment.

- Positive seal, self closing doors with 90° stay open feature. Doors swing within cabinet dimensions.
- Magnetic door gaskets of one piece construction, removable without tools for ease of cleaning.

SHELVING

- Three (3) stainless steel shelves 324 mm L x 534 mm D (12¾" x 21") per section.
- Three (3) sets of ¼gastronorm rails per section.

MODEL FEATURES

- Evaporator is epoxy coated to eliminate the potential of corrosion.
- Self-contained condensate pan. No need for external drain.

ELECTRICAL

- Unit completely pre-wired at factory and ready for final connection to a 230-240/50/1 phase dedicated outlet.
- Plug type varies by country.

OPTIONAL FEATURES/ACCESSORIES

Upcharge and lead times may apply.

- 64 mm (2½") diameter castors.
- 153 mm (6") standard legs (requires leg mounting plates).
- 153 mm (6") seismic/flanged legs (requires leg mounting plates).

PLAN VIEW

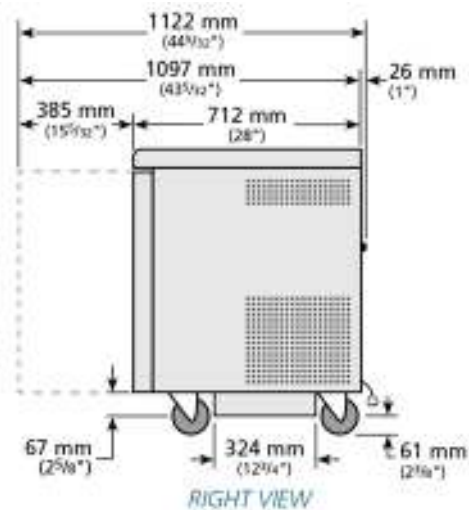
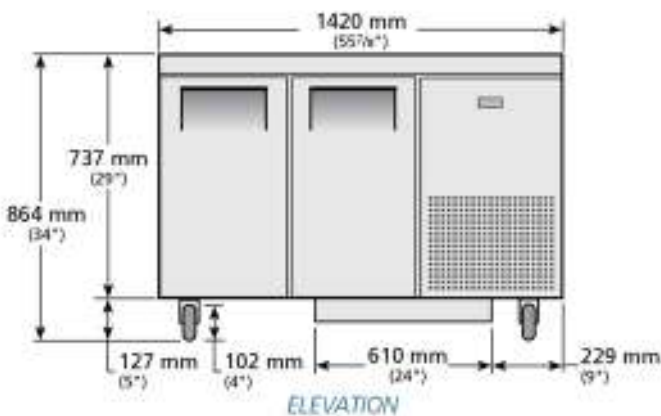

METRIC DIMENSIONS ROUNDED UP TO THE NEAREST WHOLE MILLIMETER

SPECIFICATIONS SUBJECT TO CHANGE WITHOUT NOTICE

	Model	Elevation	Right	Plan	3D	Back
	TGU-2					

TRUE EUROPE