

Technical data sheet for **GAS COOKTOPS 1200mm**

G518D-B, G518D-CB, G518D-LS, G518D-RB,
G518C-B, G518C-CB, G518C-LS, G518C-RB,
G518B-B, G518B-CB, G518B-LS, G518B-RB,
G518A-B, G518A-CB, G518A-LS, G518A-RB

- Heavy-duty construction
- 7kW open burners
- Flame failure standard
- Pilot burners optional
- 300mm, 600mm, and 900mm griddle plate options
- Optional simmer plates
- 3 models of base unit
- 1 model of ventilated refrigeration base with drawer/door options
- Rear rollers
- Stainless steel exterior
- Easy clean
- Easy service
- Fully modular



G518D-LS

Overall Construction

Cooktop

- Welded hob with 1.5mm 304 stainless steel bull nose
- Side panels 1.2mm 304 stainless steel
- Splashback 1.2mm 304 stainless steel
- Enamelled control panel
- Aluminised steel internal construction
- Cast iron 7kW open burners with forged brass cap
- Enamelled cast iron potstands
- Enamelled open burner spill covers
- Cast iron simmer plates (optional extra)
- 12mm thick mild steel griddle plate
- 2.5mm 304 stainless steel griddle splash guards
- Stainless steel spill trays

Griddle sections are standard on RH side. Available on LH side and centres to order or by conversion.

Bench mount (supplied as -B model)

- Four 63mm dia. heavy-duty 1.2mm 304 stainless steel bench legs with adjustable feet
- Adjustable height 80mm - 105mm

Cabinet base (supplied as -CB model)

- Fully modular for match suite finish
- Double skin 0.9mm 304 stainless steel interior and exterior
- Optional GN 1/1 4 position racking kit (1 or 2 cabinet bays)
- Up to eight 65mm GN 1/1 capacity
- 63mm dia. heavy-duty 1.2mm 304 stainless steel legs with two adjustable feet at front and two rollers at rear

Leg stand (supplied as -LS model)

- Fully modular for matched suite finish
- Framed top for connection to Cooktop
- 63mm dia. heavy-duty 1.2mm 304 stainless steel legs with two adjustable feet at front and two rollers at rear
- Fully modular framed stand shelf with 0.9mm 304 stainless steel finish
- Shelf to top stainless steel backstop panel for convenience and rigidity
- Suitable for rear or through shelf gas connection to Cooktop
- Quick assembly design

Refrigerated base (supplied as -RB model)

- Self contained suite matched modular base
- Ventilated system with R134a refrigerant
- -2° to +8°C temperature (Tropical Climate rated)
- Two GN 1/1 drawers and one door standard
- 100mm deep pan drawer capacity
- Heavy-duty European telescopic drawer guides
- Magnetic drawer gaskets (replaceable without tools)
- 50mm fully foamed CFC free insulation
- 304 stainless steel exterior and interior
- Anti-corrosion treated evaporator
- No condensate drain required
- 63mm dia. heavy-duty 1.2mm 304 stainless steel legs with adjustable feet
- Condensing unit removable through front of unit for service
- Easy clean interior

Controls

Cooktop

- Variable high to low controls to open burners
- Open burners flame failure standard with pilot burners optional
- Variable high to low controls to griddles
- Griddles standard with pilot, flame failure and piezo ignition
- Large easy use control knob - heat resistant reinforced
- Easy view control settings on knob

Refrigerated base

- Digital control electronic thermostat
- Automatic defrost
- Automatic evaporation of defrost water
- -2° to +8°C temperature range

Cleaning and Servicing

- All models with easy clean stainless steel external finish
- Lift off burner heads and enamelled burner spill covers
- Stainless steel spill trays under open burner and griddle sections
- Access to all parts from front of unit
- Refrigerated Base condenser removable through front of unit

Technical data sheet for GAS COOKTOPS 1200mm

Specifications

Burners

Open Burners 7kW dual flame ring with simmer rate
Griddle Burners 6kW per 300mm section

Gas power (gross)

G518D 56kW, 192,500 Btu/hr
G518C 48kW, 165,000 Btu/hr
G518B 40kW, 137,000 Btu/hr
G518A 24kW, 81,500 Btu/hr

Griddle Plate

300mm Griddle cooking surface
292mm x 475mm, 1387cm²
600mm Griddle cooking surface
592mm x 475mm, 2812cm²
900mm Griddle cooking surface
892mm x 475mm, 4237cm²

Gas connection

R 3/4 (BSP) male
All units supplied with Natural and LP gas regulator

Refrigerated base

Type
Ventilated system

Refrigerant

R134a (160grams)

Climate classification

T - tropical

Electrical connection

220-240Vac, 50Hz, 1.8A, 1P+N+E
3 pin 13A plug cordset fitted

Dimensions

Bench models
Width 1200mm
Depth 812mm
Height 315mm
Incl. splashback 485mm

All models (excluding Bench model)

Width 1200mm
Depth 812mm
Height 915mm
Incl. splashback 1085mm

Packing data

Bench and Leg Stand models
0.72m³
Width 1245mm
Depth 870mm
Height 665mm

Cabinet Base and Refrigerated Base models

1.36m³
Width 1245mm
Depth 870mm
Height 1255mm

Gas types

Available in Natural gas and LP gas, please specify when ordering
Units supplied complete with gas type conversion kits

Options

Adjustable feet at rear
Simmer plates (replaces Potstand)
Ribbed griddle plates
Joining caps
Castors

G518-B

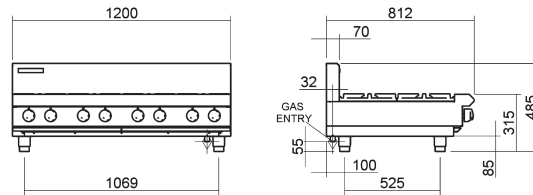

G518-LS

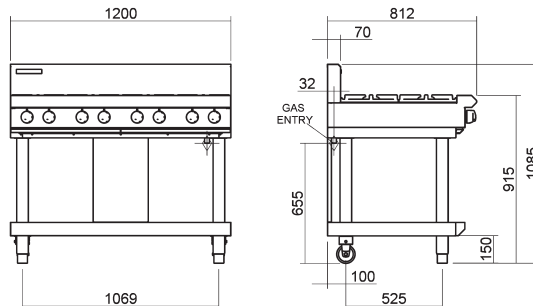

G518-CB

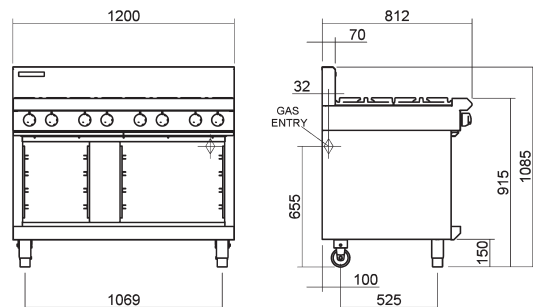

G518-RB

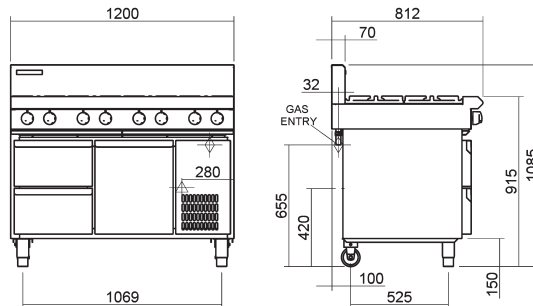

G518D

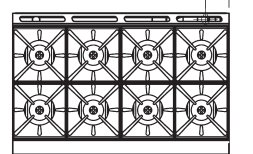

G518C

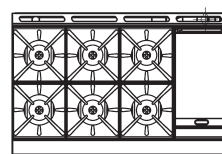

G518B

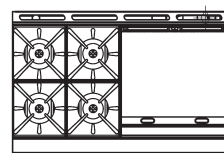

G518A

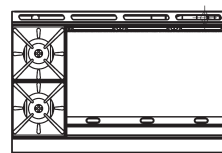

BLUE SEAL

www.blueseal.co.uk
www.bluesealevolution.com

United Kingdom Blue Seal Limited

Unit 67
Gravelly Business Park
Gravelly
Birmingham B24 8TQ
England
Telephone 0121-327 5575
Facsimile 0121-327 9711
Email sales@blue-seal.co.uk
www.blue-seal.co.uk

Australia Moffat Pty Limited

740 Springvale Rd
Mulgrave
Victoria 3170
Australia
Telephone 03-9518 3888
Facsimile 03-9518 3833
Email vsales@moffat.com.au
www.moffat.com.au

New Zealand Moffat Limited

16 Osborne St
PO Box 10-001
Christchurch 8011
New Zealand
Telephone 03-389 1007
Facsimile 03-389 1276
Email sales@moffat.co.nz
www.moffat.co.nz



Designed and manufactured by

MOFFAT

ISO9001
All Blue Seal products are designed and manufactured by Moffat using the internationally recognised ISO9001 quality management system, covering design, manufacture and final inspection, ensuring consistent high quality at all times.



In line with policy to continually develop and improve its products, Moffat Limited reserves the right to change specifications and design without notice.

Printed in China
© Copyright Moffat Ltd
Moffat/4825-UK/BH/2.5M/12.06

