



COMBI VEGETABLE PREP.-CUTTER CK-48V 230/50-60/1

2 in 1: high capacity vegetable cutter (650 kg/h) + cutter with 8 litre bowl.



1050821



SALES DESCRIPTION

It has a variable speed motor block, large-capacity head and 8-lt cutter bowl equipped with a rotor with micro-serrated blades. Brushless technology.

Equipped with “brushless” technology: powerful and efficient motors.

- ✓ Maximum efficiency: maintain the torque throughout the speed range.
- ✓ Exclusive “force control system”: guarantee of a uniform and high quality result.
- ✓ Lightweight and compact design: they weigh less, they occupy less space.
- ✓ Improved air/water-tightness since no ventilation is required.
- ✓ They generate less noise: improved workplace environment.

Cutting function: a perfect cut

- ✓ High precision settings and comprehensive cutter and disc design aimed at obtaining a perfect cut.
- ✓ It can be fitted with a wide range of discs and grids of the highest cutting quality. Combining these accessories together to obtain more than 70 different types of cuts and grating grades.
- ✓ Exclusive “Force Control System” to optimise and standardise the cutting of each product: acoustic warning when the motor exceeds the pre-established force.

Cutter function: efficiency and performance

- ✓ Possibility of programming by time and pulse button.
- ✓ Reverse function, ideal for mixing products instead of cutting.
- ✓ 8 litre stainless steel bowl.
- ✓ Polycarbonate lid with built-in “cut&mix” mixer.
- ✓ Depending on the purpose, the possibility of using optional smooth or perforated blades.

Built to last

- ✓ Made from stainless steel and food-grade materials of the highest

quality: stainless steel motor block and food-grade aluminium head. Stainless steel bowl with highly-resistant polycarbonate lid.

Maximum comfort for the user

- ✓ Ergonomic design. Maximum comfort for the user.
- ✓ Lateral product output: it requires less room on the work surface and directs the product avoiding splashing.
- ✓ Advanced control panel that is very intuitive to use and offers all the information at a glance.

Maintenance, safety, hygiene

- ✓ Plunger, lid and hopper easy to remove for changing or cleaning.
- ✓ Combination of security systems: head, covers, bowl, power switch.
- ✓ Appliance certified by NSF International (regulations on hygiene, cleaning and materials suitable for contact with foods).
- ✓ 100% tested.

INCLUDES

- ✓ Variable speed motor block.
- ✓ Large capacity head.
- ✓ Cutter bowl, with micro-serrated blade rotor.

OPTIONAL

- Tube head.
- High production semi-automatic bowl.
- Discs, grids and disc support.
- Rotor with smooth cutting blades.
- Rotor with perforated cutting blades.
- Support-trolley.
- Grid cleaning kit.

ACCESSORIES

- FCC Curved Slicing Discs
- FCO Rippled Slicing Discs
- FFC Chipping Grids
- FMC Dicing Grids
- FCE Julienne Discs
- FR Shredding & Grating Discs
- Disc and Grid Holder
- Blades for CK / K / KE
- Grid Cleaning Kit
- FC-D Slicing Discs
- SH Shredding & Grating Discs

SPECIFICATIONS

Total loading: 1500 W

Electrical supply: 230 V / 50-60 Hz / 1 ~ (10 A)

Plug: EU (SCHUKO 2P+G)

As vegetable preparation machine

Hourly production: 200 Kg - 650 Kg

Inlet opening: 286 cm²

Disc diameter: 205 mm

Speed as veg. slicer: 300 rpm - 1000 rpm

External dimensions (WxDxH): 391 mm x 400 mm x 652 mm

Net weight (Veg.Pre): Net weight (Veg.Pre)

As cutter

Bowl capacity: 8 l

Speeds as cutter (positions): 300 rpm - 3000 rpm

External dimensions (WxDxH): 286 mm x 387 mm x 517 mm

Net weight (Cutter): 19 Kg

Noise level (1m.): <70 dB(A)

Background noise: 32 dB(A)

Crated dimensions

705 x 415 x 515 mm

Volume Packed: 0.15 m³

Gross weight: 36.1 Kg

DYNAMIC PREPARATION
FOOD PROCESSOR / VEG PREP COMBI MACHINES

product sheet
updated 24/02/2022





COMBI VEGETABLE PREP.-CUTTER CK-48V 230/50-60/1

2 in 1: high capacity vegetable cutter (650 kg/h) + cutter with 8 litre bowl.



1050821

DYNAMIC PREPARATION
FOOD PROCESSOR / VEG PREP COMBI MACHINES

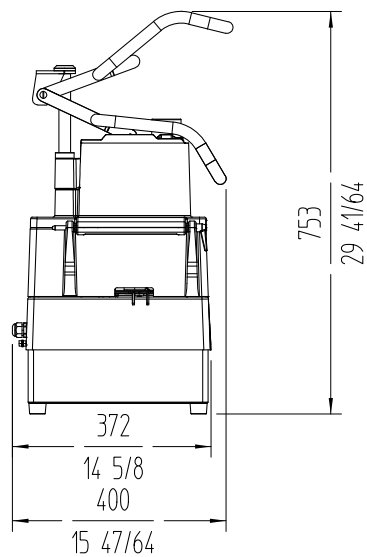
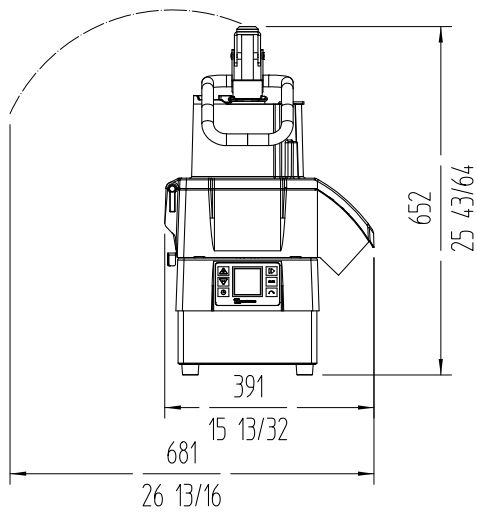
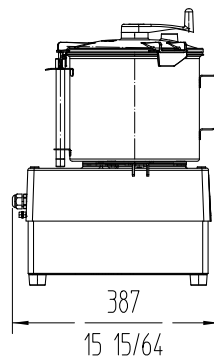
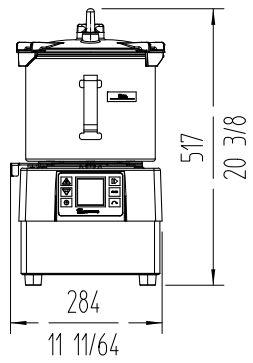

www.sammic.co.uk

Food Service Equipment Manufacturer

Unit 2, Trevanth Road
Troon Industrial Park
LE4 9LS - Leicester

uksales@sammic.com
Tel.: +44 0116 246 1900



Project	Date
Item	Qty
Approved	

product sheet
updated 24/02/2022