

Hand slicer 300 - 350

Anniversario



Ed. 04/2010

Instruction Manual for Use and Maintenance

**SIRMAN**[®]

FOREWORD

- This manual is meant to provide **Customers** with information on the machine and its specifications, and provides all the safety measures and standards, operating and maintenance instructions in order to ensure machine performance and longevity.
- This manual is to be kept until the machine is disposed of.
- This manual should be made accessible to all operators and maintenance personnel.

INDEX

| | |
|---|--------|
| CHAP. 1 – RECEIVING THE SLICER | pg. 4 |
| 1.1 PACKAGING | |
| 1.2 - CHECKING PACKAGING UPON RECEIPT OF SLICER | |
| CHAP. 2 – INSTALLING THE SLICER | pg. 6 |
| 2.1 UNPACKING | |
| 2.2 - SLICER LOCATION | |
| 2.3 - SERIAL NUMBER PLATE | |
| CHAP. 3 – INFORMATION ABOUT THE SLICER | pg. 8 |
| 3.1 - GENERAL SAFETY MEASURES | |
| CHAP. 4 – GETTING FAMILIAR WITH THE SLICER | pg. 10 |
| 4.1 - STRUCTURAL AND DESIGN FEATURES | |
| 4.2 - SAFETY PROTECTIONS FITTED | |
| 4.2.1 - Mechanical safety protections | |
| 4.3 - MACHINE DESCRIPTION | |
| 4.4 - OVERALL DIMENSIONS, WEIGHT, SPECIFICATIONS... | |
| CHAP. 5 – USING THE SLICER | pg. 13 |
| 5.1 - OPERATIONAL CHECKS | |
| 5.2 - LOADING AND SLICING THE FOOD PRODUCT | |
| 5.3 - SHARPENING THE BLADE | |
| CHAP. 6 – ROUTINE CLEANING OPERATIONS | pg. 16 |
| 6.1 FOREWORD | |
| 6.2 - CLEANING THE MACHINE | |
| 6.2.1 - Cleaning the product hopper | |
| 6.2.2 - Cleaning the blade | |
| 6.2.3 - Cleaning the ring | |

- 6.2.4 - Cleaning the blade guard
- 6.2.5 - Cleaning the sharpener
- 6.2.6 - Cleaning removed parts
- 6.3 GREASING SLIDE GUIDES

CHAP. 7 – MAINTENANCE

pg. 19

- 7.1 FOREWORD
- 7.2 CHAINS AND SPROCKETS
- 7.3 GEARS
- 7.4 SUPPORT FEET
- 7.5 BLADE
- 7.6 SPRING
- 7.7 GREASING SLIDE GUIDES

CHAP. 8 – SCRAPPING

pg. 19

- 8.1 - PUTTING OUT OF SERVICE
- 8.2 SCRAPPING

CHAP. 1 – RECEIVING THE SLICER

11.1 – PACKAGING

The slicer is packed in (*Fig. n. 1*):

- a cardboard box;
- on a wood pallet;
- in a protective plastic bag. Packaging materials must be disposed of separately and in conformity with waste treatment legislation in force in the country of use .

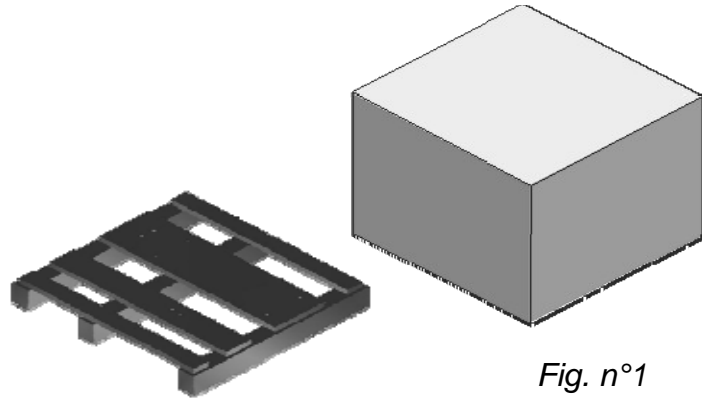

Fig. n°1

| | Dimensions AxBxC (mm) | Gross weight (Kg) |
|-----|-----------------------------|-------------------------|
| 300 | 960x920x860 | 78 |
| 350 | 960x920x860 | 90 |

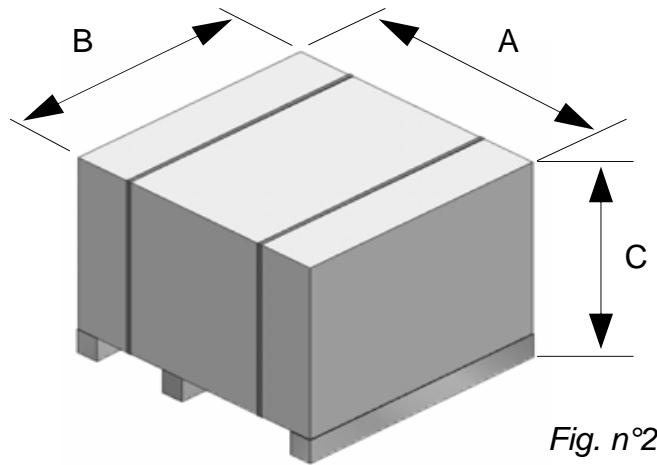

Fig. n°2



CAUTION !

Do not stack boxes on top of one another (*Fig. n°3*).

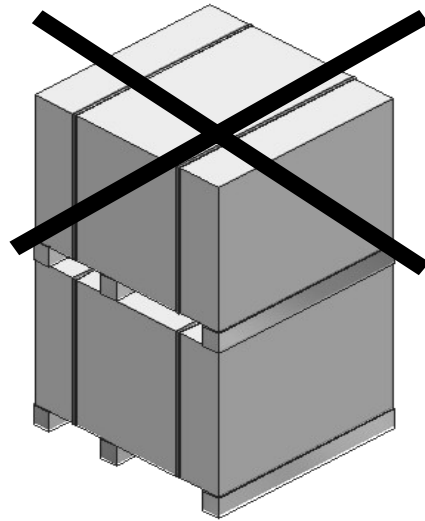

Fig. n°3



Do not leave the package in the rain or in a damp location (*Fig. n°4*).

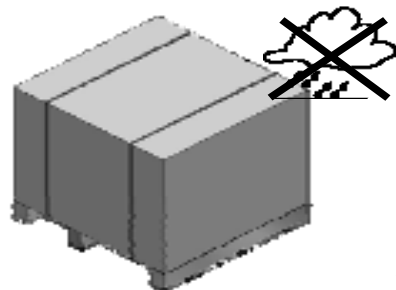

Fig. n°4



Heavy weight package. Do not manually lift the packed slicer without the help of another person (*Fig. n°5*).

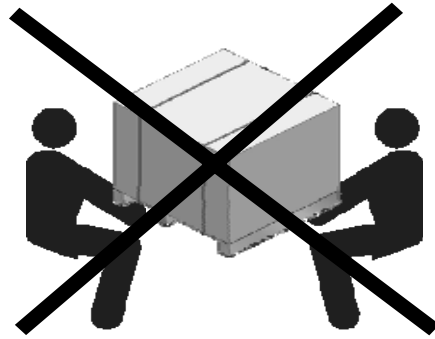

Fig. n°5



To handle and move the package utilise suitable manual or electric material handling equipment fitted with suitable lifting accessories (*Fig. n°6*).

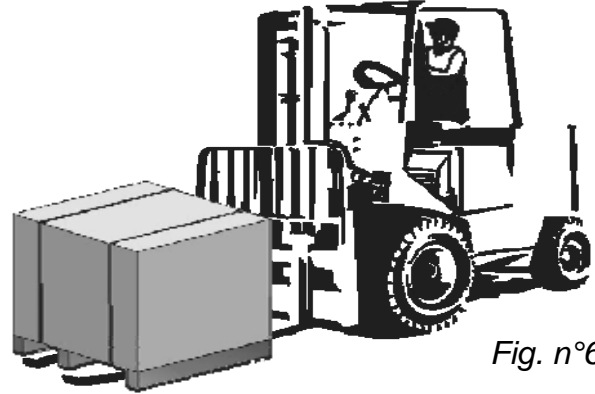

Fig. n°6



As the centre of gravity of the package is off-centre do not use lifting slings or other similar lifting and handling equipment (*Fig. n.7*) to move the package .

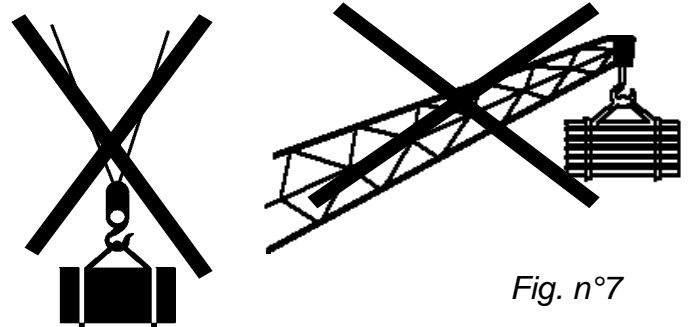

Fig. n°7

1.2 - CHECKING PACKAGING UPON RECEIPT OF SLICER

Upon receipt of the slicer check packaging shows no signs of damage and then open and check that all the parts are included. If packaging shows signs of damage (*Fig. n.8*) impacts or other, inform the carrier immediately of such damage and within 3 days from the delivery date provided in the transport document write a report listing the damage. **Do not overturn the package!!** When handling lift the box at the four corners (make sure it remains vertical to the ground).

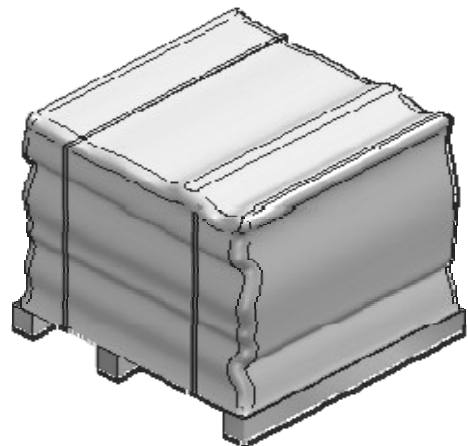

Fig. n°8

CHAP. 2 – INSTALLING THE SLICER

CAUTION!

Only qualified persons should handle and lift the packed slicer (Fig. n°9).



Fig. n°9

2.1 - UNPACKING

Remove straps from packaging (Fig. n.10) and remove the cardboard box (h). The box should contain:

- a) machine on pallet (detail a Fig. n.11);
- b) 4 support feet (detail b Fig. n.11);
- c) Instruction booklet (detail c Fig. n.11);
- d) a card and box containing the slice receiving plate.

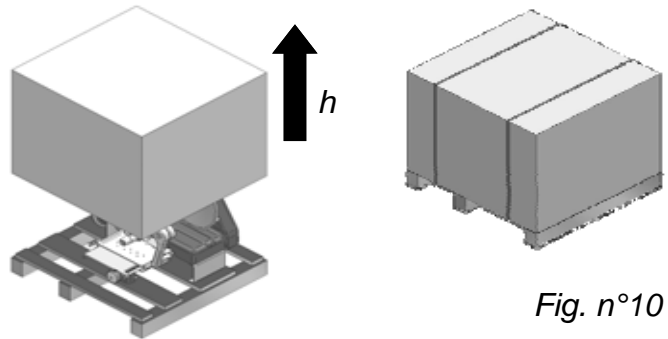

Fig. n°10

2.2 - SLICER LOCATION

Position the pallet, with the slicer, on a flat surface and remove (a) the cap from the slicer (Fig. n.12).

Utilising the correct wrench provided unscrew the 4 nuts (Fig. n.13) which secure the slicer to the pallet and remove the 4 washers. Remove the pallet and screw the 4 support feet provided to the slicer. Now lift the carriage (a) off the fixture bracket (Fig. n.14).

Finally, replace cap in its original position.

Position the slicer in its final operating location.

The dimensions indicated in Tab. 1 (pg.12) must always be considered and taken into account for when deciding on

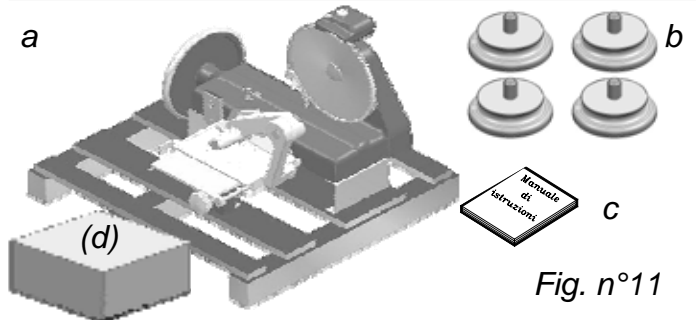

Fig. n°11

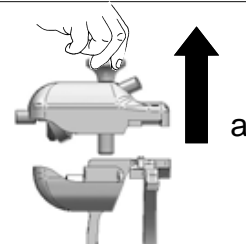

Fig. n°12

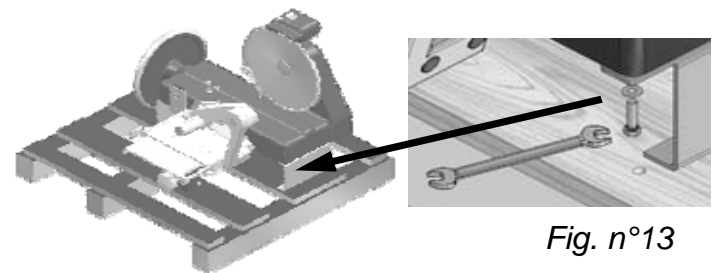

Fig. n°13

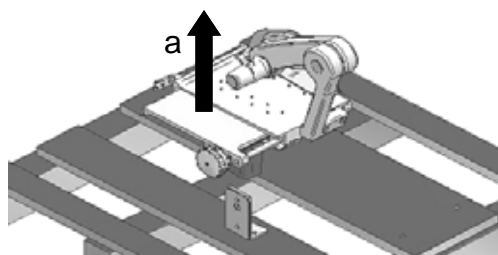
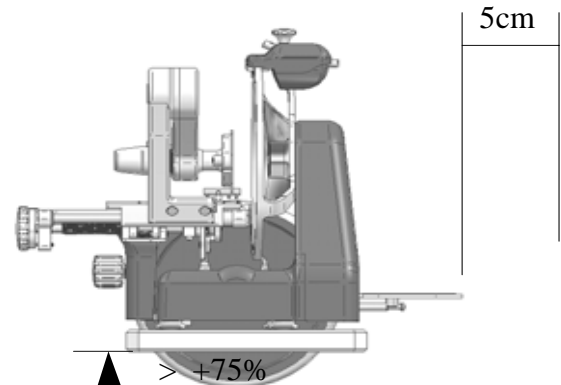
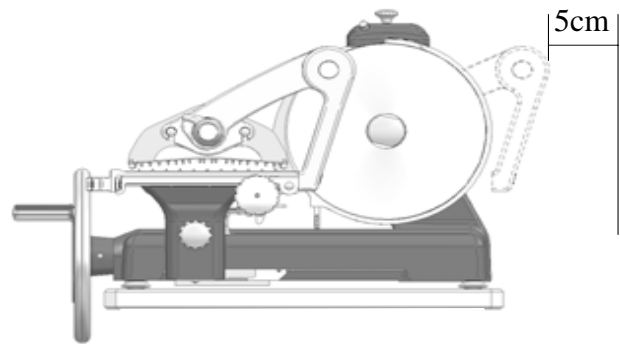

Fig. n°14

the final location of the slicer. Slicer location must be wide enough to accommodate the slicer, level, dry, smooth, robust, stable and at a height of approximately 80 cm from the ground and at least with a 5 cm gap from walls, objects, shelves, etc. (Fig. n.15) to allow for sufficient room to operate the slicer respecting and safeguarding operator safety. Furthermore, the machine must be located in an environment with a maximum humidity of 75%, non-saline and with a temperature ranging between +5°C and +35°C; and in any event in environments which conform to the above specifications *Tab. 1 (pg.12)*.



> +35°C

~ 80cm

Fig. n°15

2.3 - SERIAL NUMBER PLATE

Check that all the information provided on the serial number plate affixed to the machine (Fig. N.17) corresponds to the information provided in the transport documents and purchase order. In the event of discrepancies contact the manufacturer .

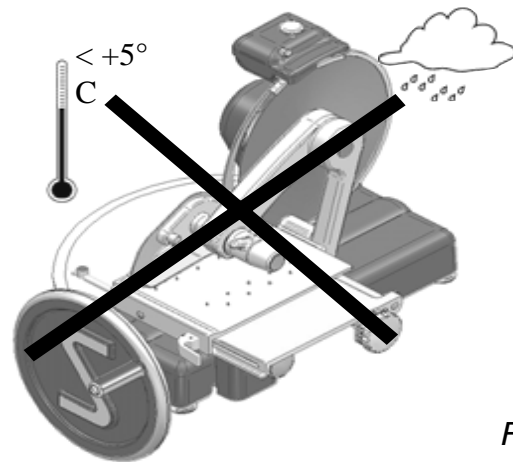

Fig. n°16

| | |
|------------|-------|
| MOD: | _____ |
| Kg: | _____ |
| ANNO: | _____ |
| SERIAL NO: | _____ |

Fig. n°17

CHAP. 3 – INFORMATION ABOUT THE SLICER

3.1 - GENERAL SAFETY MEASURES

The general measures, although they appear obvious, are fundamental and must be respected when installing, using and servicing the machine and for dealing with possible malfunctions.

- The slicer has been designed to cut fresh boneless meat and prepared sausage meat products (Fig. n. 18). Any other use, including slicing vegetables, is considered improper and therefore hazardous.
- The Manufacturer shall not be held responsible for:

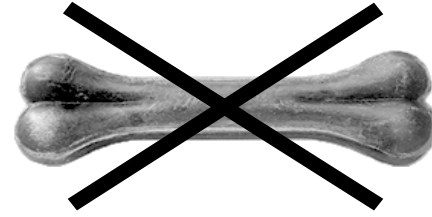

Fig. n°18

- ⇒ **the instructions in this manual are not followed carefully;**
- ⇒ **machine surfaces are treated with unsuitable products.**
- ⇒ **the machine is tampered with by unauthorised personnel;**
- ⇒ **components are replaced with non-original parts;**



ATTENZIONE!

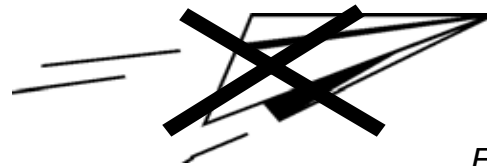

Fig. n°19

- Keep this manual in a safe and accessible place for future reference (Fig. n° 19).
- The slicer must only be used by trained personnel who have knowledge of the safety standards provided in this manual.
- In the event of staff turnover, new operators must be properly trained.
- Do not allow the slicer to be used by children or by untrained people (Fig. n. 20).
- When performing routine maintenance or cleaning the slicer (the guards are removed), carefully evaluate all residual risks.
- During maintenance or cleaning it is of utmost importance that the operator is fully concentrated on the operations being performed.
- Do not use corrosive or flammable substances to clean the slicer (Fig. n. 21) only use neutral cleaning detergents (pH7).

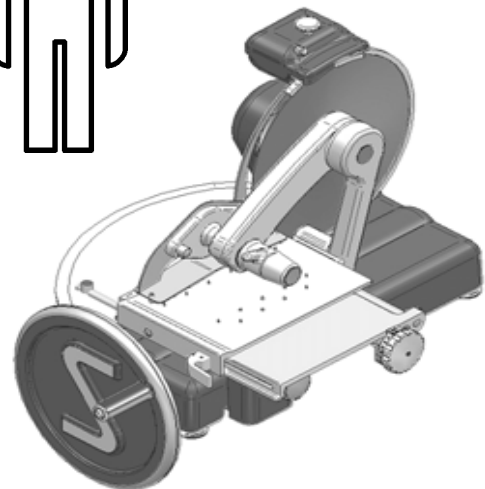
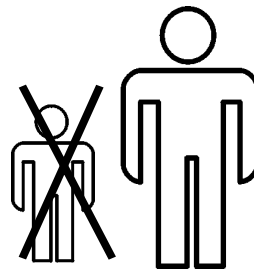

Fig. n°20

- To clean the slicer carefully follow the instructions in the chapter: “Routine cleaning operations”.
- Do not wash the slicer or parts of the slicer in a dishwasher (Fig. n.22) or with water jets, do not place in water or in other liquids.
- Do not leave the slicer exposed to damaging weather agents such as sun, rain, liquid sprays, humidity, ice (Fig. n.23).



ATTENZIONE!

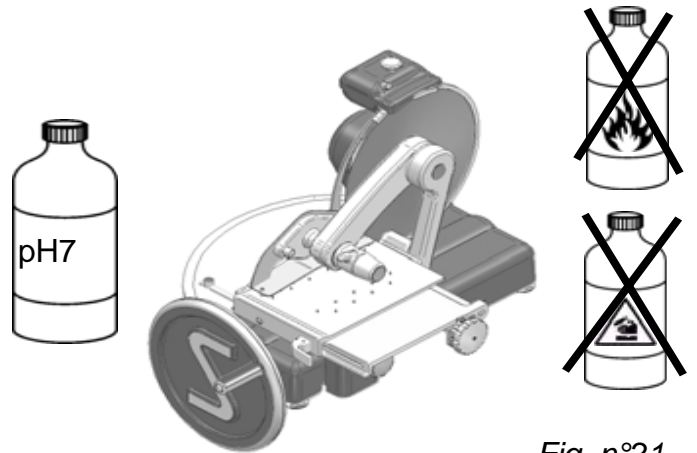

Fig. n°21

- If the machine remains unused for long periods of time, before using it again have it overhauled and checked by a “Service Centre”.
- If the slicer show signs of malfunctioning, it is recommended not to use it, do not repair, but contact the “Service Centre”, details are provided on the back cover of this manual.

- Although safety devices are fitted to protect hazardous points on the machine, do not place hands near the blade and other moving parts.

- **Never slice the product almost finished without utilising the product pusher. Do not place yourself in a position that causes parts of the body to come into direct contact with the blade.**

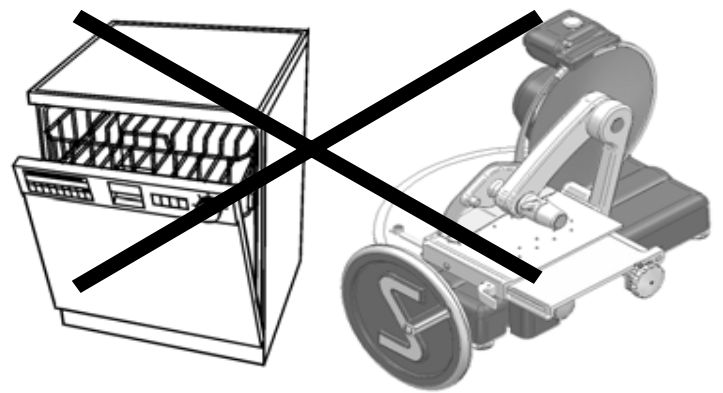

Fig. n°22

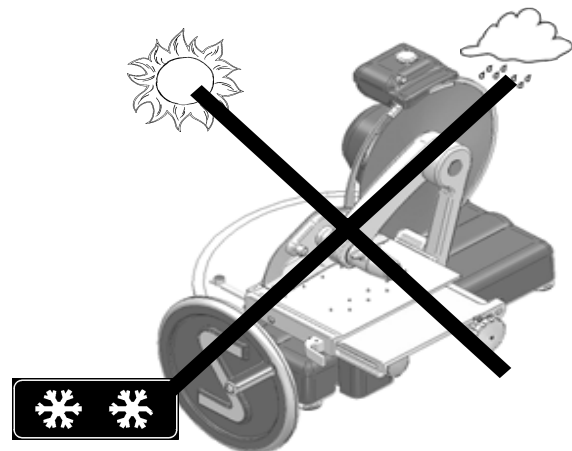

Fig. n°23

CHAP. 4 – GETTING FAMILIAR WITH THE SLICER

4.1 – STRUCTURAL AND DESIGN FEATURES

The slicer is manufactured from spheroidal cast iron quality G25 with a paint finish and is provided with a tempered glass slice receiving plate. As the slicer is used with food products this glass plate ensures hygiene and is highly resistant to acids, salts and rust.

The blade is manufactured from milled hardened steel quality grade 100 Cr6 with a chrome plated finish ensuring precision slicing even after sharpening. The majority of the parts are manufactured from:

- anodised aluminium alloy
- steel grade AISI 430 or 304 .

LEGEND:

- 1** - Base
- 2** - Handwheel
- 3** - Hand grip for handwheel
- 4** - Glass slice receiving plate
- 5** - Support foot
- 6** - Stem
- 7** - Hand grip for stem
- 8** - Knob carriage release
- 9** - Cap
- 10** - Cap knob
- 11** - Product hopper
- 12** - Carriage
- 13** - Slice thickness gauge
- 14** - Product pusher
- 15** - Hand grip product pusher
- 16** - Blade
- 17** - Ring
- 18** - Bracket product pusher
- 19** - Blade guard
- 20** - Slice guard
- 21** - End stop

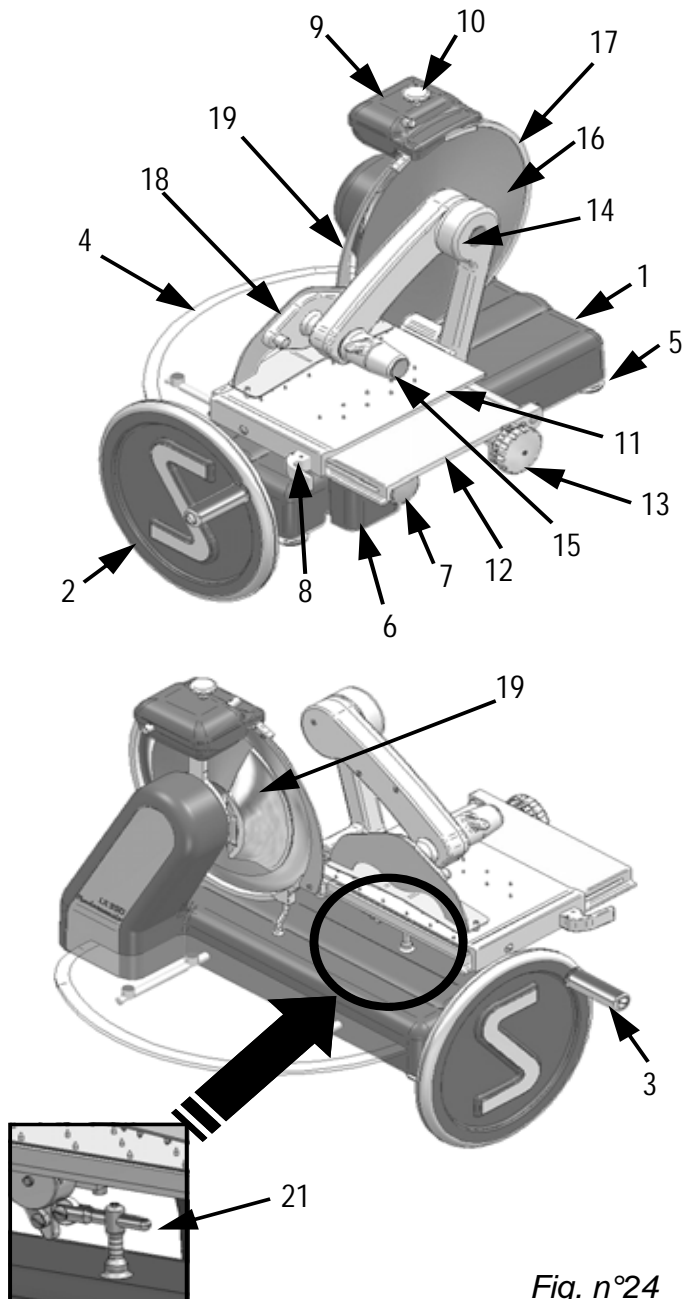

Fig. n°24

4.2 - SAFETY PROTECTIONS FITTED

4.2.1 - Mechanical safety protections The mechanical safety protections fitted are:

- ring
(rif. n°1 Fig. n°25);
- cap
(rif. n°2 Fig. n°25);
- Food pusher
(rif. n°3 Fig. n°25);
- Hand grip for food pusher (rif. n°4 Fig. n°25);
- housing blade guard
(rif. n°5 Fig. n°25);

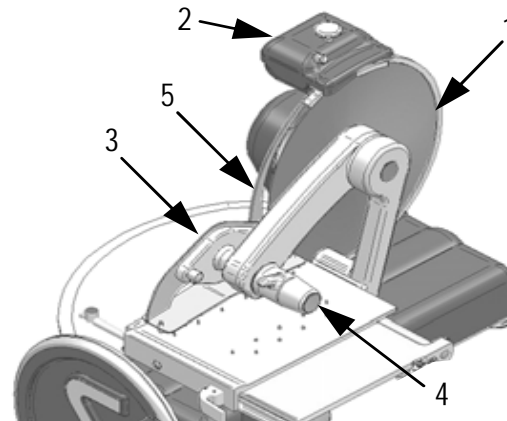

Fig. n°25

Although the slicer is fitted with mechanical safety protections (for slicing and for cleaning and maintenance operations), **RESIDUAL RISKS** exist and cannot be completely eliminated. These risks are highlighted in this manual under the wording **CAUTION**. They concern hazards related to cutting, bruising and other injuries caused by the blade or by other machine parts.

4.3 - MACHINE DESCRIPTION

The handwheel slicers have been designed and manufactured by our company with the precise purpose of slicing food products (cold sausage meats and meat products) and guarantee:

- maximum slicing precision;
- all components are of robust and stable construction;
- maximum silence;
- easy to handle.
- maximum safety in use, cleaning and maintenance operations;
- maximum hygiene thanks to a meticulous selection of materials that come into contact with the food products, and by eliminating sharp edges which come into contact with the product facilitating cleaning and part removal;

4.4 - OVERALL DIMENSIONS, WEIGHT, SPECIFICATIONS ...

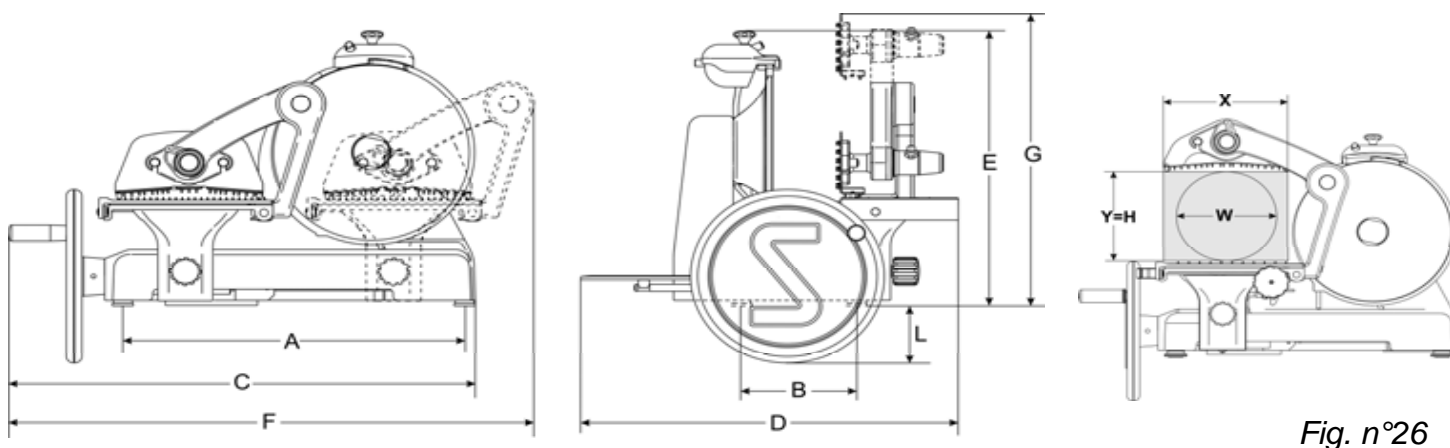

Fig. n°26

TAB.1 OVERALL DIMENSIONS, WEIGHT, SPECIFICATIONS (Fig. n° 26)

| | U.m. | 300 | 350 |
|-----------------------------|------------------------|-------------|-------------|
| Blade diameter | <i>mm/inch.</i> | 300 / 12" | 350 / 14" |
| Cutting thickness | <i>mm</i> | 0÷3 | 0÷3 |
| Carriage travel | <i>mm</i> | 285 | 345 |
| Hopper dimensions | <i>mm</i> | 270x295 | 320x350 |
| AxB | <i>mm</i> | 520x180 | 592x180 |
| CxDxE | <i>mm</i> | 770x625x510 | 820x780x560 |
| FxDxG | <i>mm</i> | 855x625x590 | 910x780x615 |
| L | <i>mm</i> | 90 | 120 |
| Slicing capacity | | | |
| X | <i>mm</i> | 270 | 330 |
| Y | <i>mm</i> | 200 | 255 |
| H | <i>mm</i> | 200 | 255 |
| W | <i>mm</i> | 200 | 255 |
| Net weight | <i>Kg</i> | 60 | 72 |
| Ratio blade rotation | <i>Operator: blade</i> | 1:2 | 1:2 |

CHAP. 5 – USING THE SLICER

5.1 - OPERATIONAL CHECKS

When the slicer is used for the first time, proceed as follows:

- check the slicer is correctly installed refer to **chapter 2**;
- check that the hopper is securely fastened utilising the lock knob (ref.1 Fig. n.27);
- by turning the handwheel (ref.2 Fig. 28) clockwise (ref .a Fig. n.28), check the hopper travels freely and there are no obstacles on the counter ((ref. b Fig. n. 28);

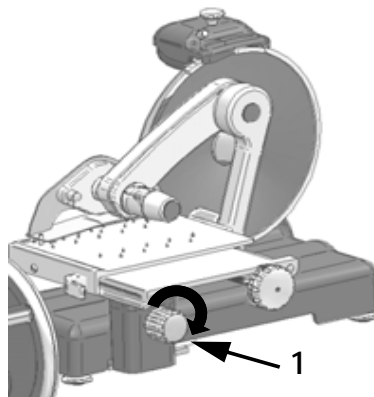

Fig. n°27

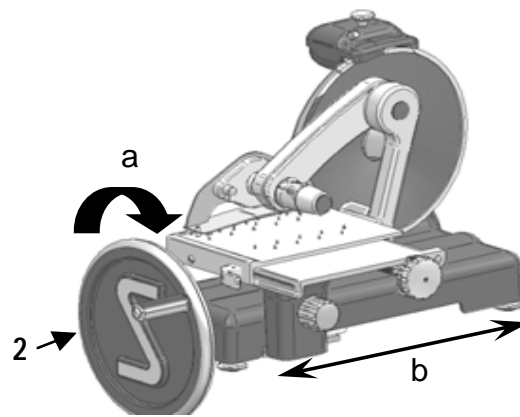

Fig. n°28

- by turning the hand grip (ref. 3 Fig. n.29) clockwise (Fig. n.29) check the product pusher can be raised and lowered easily and movement is not impeded in any way;

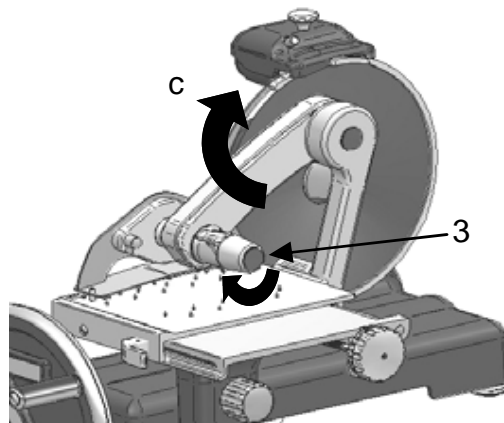

Fig. n°29

- check the sharpener is securely fastened to the machine and can be easily removed and free of obstacles (Fig. n. 30 ref. d).

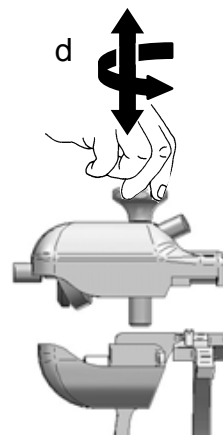

Fig. n°30

5.2 - LOADING AND SLICING THE FOOD PRODUCT

CAUTION: be careful not to touch blade and metal spikes.

Before loading the food product to slice make sure the carriage is in position start of travel if not proceed as follows :

1. pull the carriage, release knob towards you (*Fig. n.31 detail. a*); slide the carriage
2. outwards (*Fig. n.31 detail. b*);

To load the product proceed as follows :

1. release the food pusher utilising the hand grip (*Fig. n.32 detail .1*) and raise (*Fig. n.32 detail c*) food pusher; place the food to slice on the hopper and block in place with spiked food pusher (*Fig. n.33*);
3. using the thickness gauge knob (*Fig. n. 32 detail.2*) select required slice thickness;
4. position yourself correctly to prevent accidents; with your right hand grip the handgrip on the handwheel and then position your hand near the slice guard to receive the cut slices (do not touch the blade). Always remain in an upright position in respect to the (*Fig. n.33*) counter.
5. **CAUTION:** Do not stand in a position which causes parts of your body to come in contact with the blade (**e.g. Fig. n.34**).
6. turn the handwheel clockwise (*Fig. n.33 detail d*) so that the carriage (hopper + food pusher + stem) slides towards the blade. The food product comes into contact with the blade, the blade cuts the slice, the slice is then fed through the slice guard and falls onto the glass slice receiving plate (*Fig. n.35*);
7. If the sliced product has a threaded or rough appearance, sharpen the

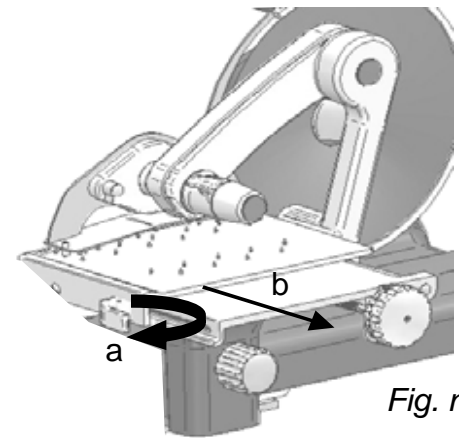

Fig. n°31

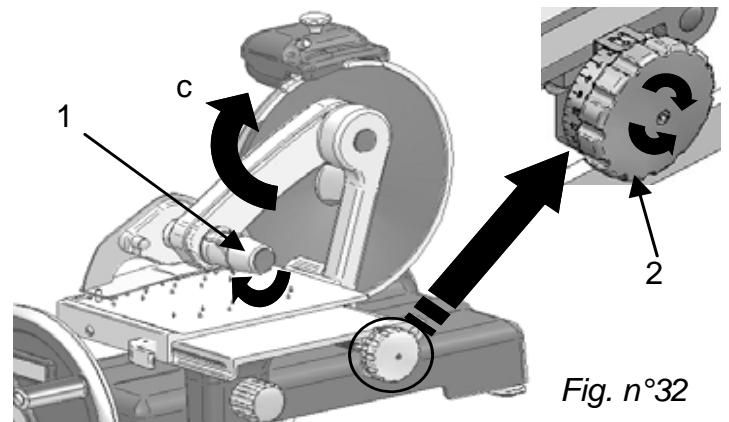

Fig. n°32

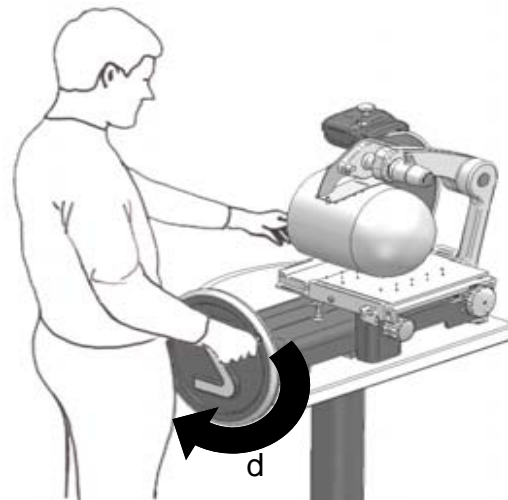

Fig. n°33

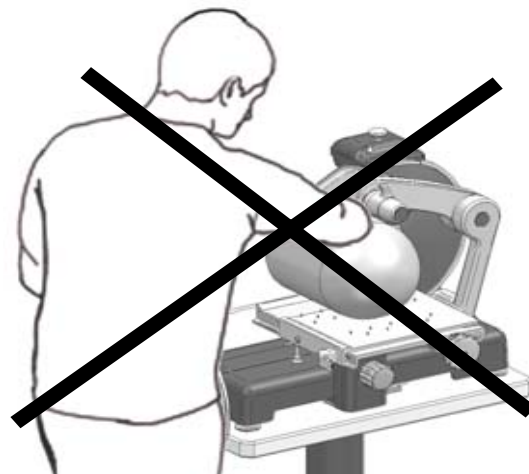

Fig. n°34

blade to prevent creating excessive pressure on the blade (**chapter 5.3**).

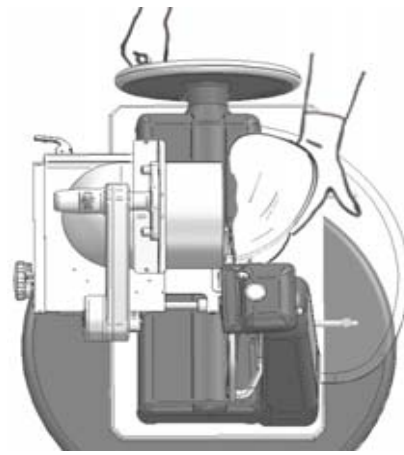

Fig. n°35

5.3 - SHARPENING THE BLADE

CAUTION: Before proceeding with blade sharpening, evaluate **RESIDUAL RISKS** (chapter 4.2.1) concerning hazard of injury if the below instructions are not respected.

The slicer blade should be sharpened periodically the moment slicing precision and performance diminishes. To sharpen slicer blade follow and respect the below instructions :

1. with a damp cloth thoroughly clean the blade, use a neutral detergent to remove any grease build-up on the blade (refer to chap. 6.2.2);
2. lift (Fig. n.36 detail a) the sharpener cap (Fig. n.36 detail 1) and rotate 180° (Fig. n.36 detail b);
3. release the cap (Fig.n.37 detail c) so that it fits onto the locator pins (Fig. n.37 detail d);
4. check that the blade is between the two grinders;
5. by turning the handwheel clockwise rotate the blade (Fig. n.33);
6. press the sharpening button (Fig.n.38 detail 2), leave the blade to rotate between the grinders for approximately 30/40 seconds until the blade edge is slightly burred;

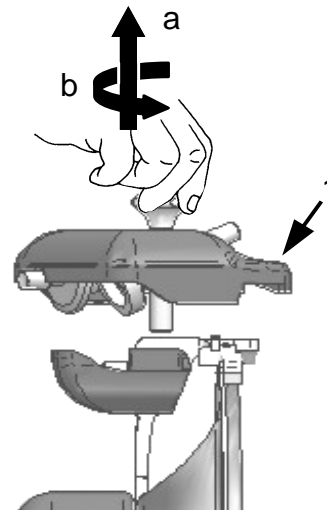

Fig. n°36

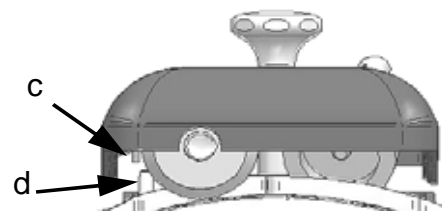

Fig. n°37

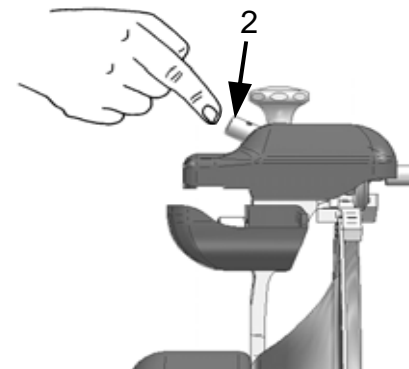

Fig. n°38

- 7.. press the pushbuttons (Fig. n.39 details 2 and 3) simultaneously for 3/4 sec and release.
8. after sharpening it is recommended to clean grinders and blade (**chapter 6.2.3**); once sharpening is completed, replace the sharpening device in its original position
9. inverting the above procedure .

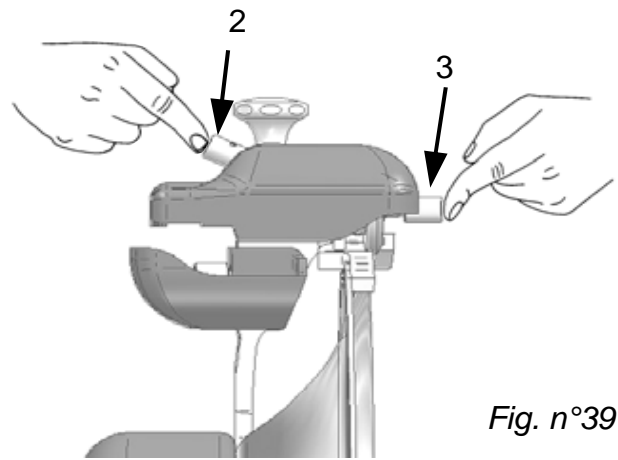

Fig. n°39

N.B.: dressing should not exceed more than 3/4 sec. to prevent damaging the blade edge.

CHAP. 6 – ROUTINE CLEANING OPERATIONS

6.1 - FOREWORD

- The slicer must be cleaned at least once a day and if necessary, more frequently.
- All the parts of the slicer that come into direct or indirect contact with the food product must be scrupulously cleaned.
- The slicer must not be cleaned with water cleaning machines, water jets or in a dishwasher. Use a water and neutral detergent solution only (pH 7). Rinse with clean water and dry with a soft cloth. Never use utensils, brushes and or other tools which could damage the machine surface.

CAUTION: evaluate residual risks due to sharp parts which could cause injury. Always wear protective safety gloves (Fig. n° 42).

6.2 - CLEANING THE MACHINE 6.2.1 – Cleaning the product hopper

- The hopper assembly (hopper + pusher + stem) is easy to remove:
- By turning the hand wheel move the hopper assembly (Fig. n.40 detail.1) to end of travel (Fig. n.40 detail 2) towards yourself – operator side
- Unscrew the hopper lock knob (Fig. n.40 detail 3) and slide the assembly sideways (Fig. n. 40 detail 3)
- Once the assembly is removed, the hopper can be cleaned with warm water and a neutral pH7 detergent (Fig. n°41).

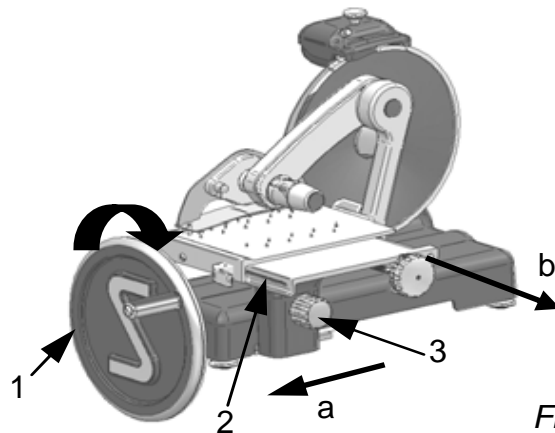

Fig. n°40



Fig. n°41

6.2.2 - Cleaning the blade

CAUTION

To prevent cutting hazards a pair of metal gloves must be worn when cleaning the blade (Fig. n.42).

- with a soft cloth (Fig. 43 detail a), press the surface of the blade (Fig. n.43 detail 1) on both sides of the ring and slowly wipe from the centre of the blade outwards,
- Dry in the same way with a dry cloth.

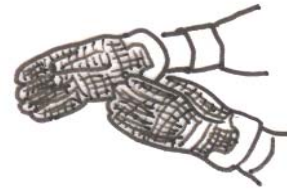

Fig. n°42

6.2.3 - Cleaning the ring

- remove the sharpener from its compartment (Fig. n.43 detail 3); pass a damp cloth through the gap between the blade (Fig. n.44 detail 1) and ring (Fig. n.44 detail 2); gripping the cloth (Fig. n.44 detail a) and pressing slightly against the inside of the ring manually rotate the cloth together with the blade a full turn.
- turn the slice guard (detail 1) until it is half open;
- push the slice guard downwards (Fig. n.45 detail a), move the lower part outwards (Fig. n. 45 detail b) to release the slice guard from the top pin.

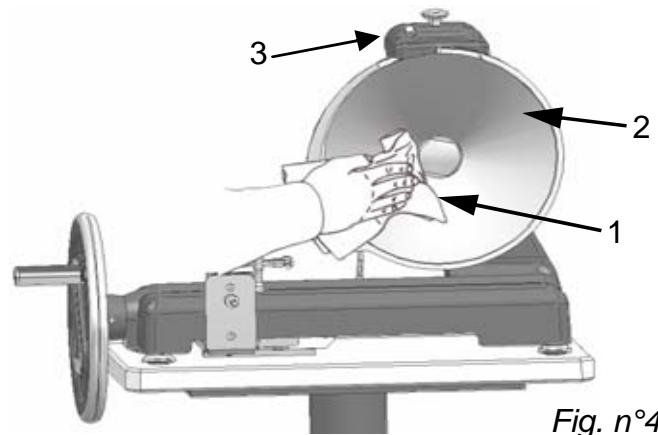

Fig. n°43

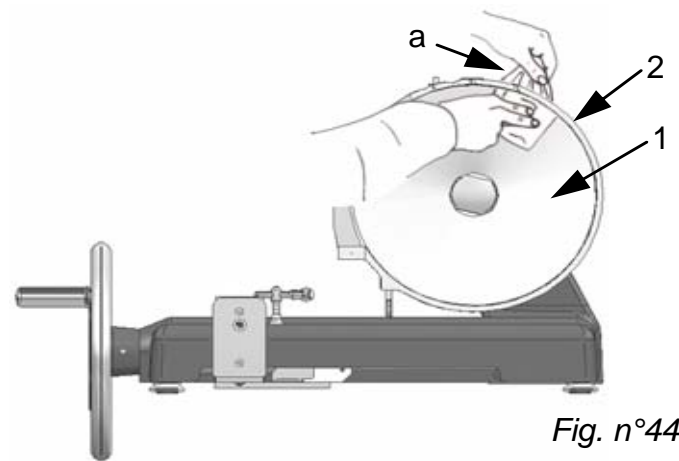

Fig. n°44

6.2.4 - Cleaning the blade guard

To remove the slice guard proceed as follows:

- At this point clean the slice guard with a warm water and neutral detergent (pH 7) solution. Rinse with clean water and dry with a soft cloth.
- To replace the slice guard invert the above procedure.

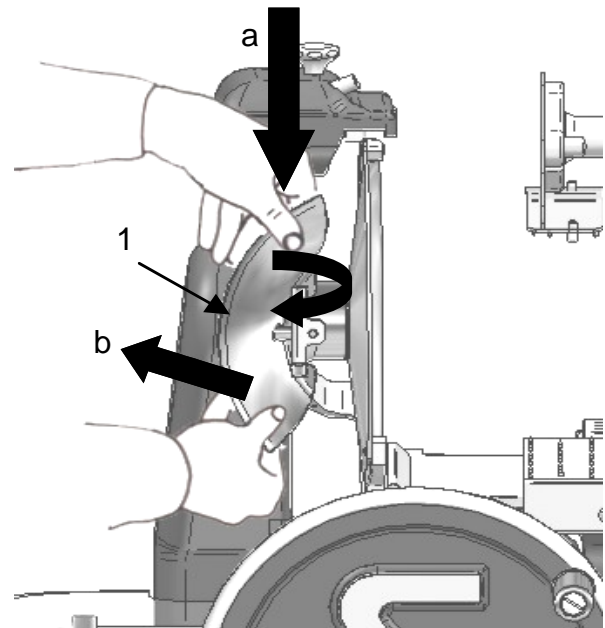

Fig. n°45

6.2.5 - Cleaning the sharpener

To clean the sharpener proceed as follows :

1. raise (Fig. n.46 ref. a) the cap until end of travel;
2. loosen the knob (Fig. n.47 ref.1);
3. raise (Fig. n.47 ref. b) the casing (Fig. n.47 ref.2) and remove (Fig. n.47 ref. c) Make sure the knob (Fig. n.47 ref.1) passes through the largest opening in the casing (Fig. n.47 ref.2);
4. rub the grinders with a brush. For the other components use a warm water and neutral detergent (pH 7) solution (pH 7).

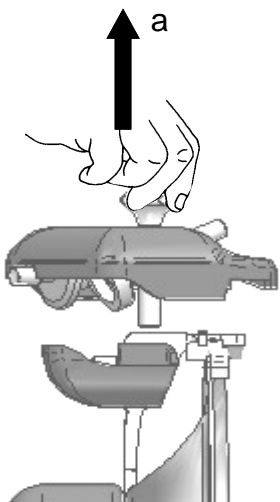

Fig. n°46

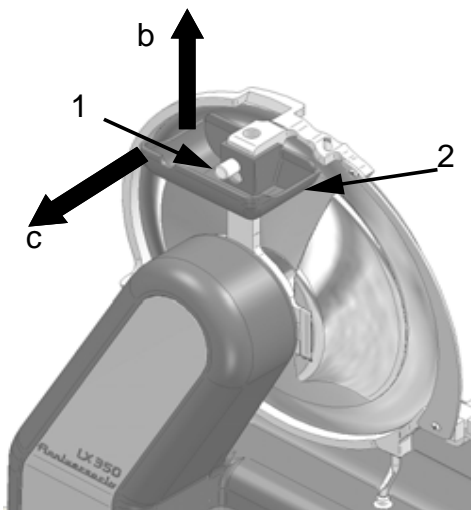

Fig. n°47

6.2.6 - Cleaning removed parts

All parts removed must be cleaned with a neutral detergent or disinfectant. Once cleaned all parts are to be rinsed with plenty of clean water and **DRIED THOROUGHLY** .

CAUTION

Take care when cleaning the hopper and pusher as these have spiked surfaces. We recommend you use protective metal safety gloves. Do not wash components and parts in the dishwasher.

Furthermore, the hopper and pusher must not be placed in any type of liquid as liquids can penetrate into the internal mechanisms causing damage. **IMPORTANT: use only a water and neutral detergent (pH 7) solution for cleaning, use clean water to rinse and soft cloths for cleaning and drying .**

6.3 - GREASING SLIDE GUIDES

The slide guides on the hopper assembly (1-2) must be lubricated periodically with the oil (a) provided (Fig. n.48 ref a).

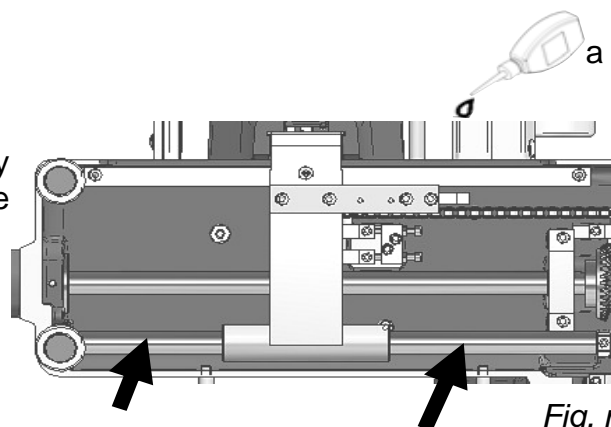

Fig. n°48

CHAP. 7 – MAINTENANCE

7.1 - FOREWORD

Before proceeding with maintenance evaluate all **RESIDUAL RISKS** related to spiked and sharp parts. To prevent cutting hazards a pair of metal gloves must be worn when cleaning the blade.

7.2 - CHAINS AND SPROCKETS

The chain does not require adjustment but simply periodic greasing. Use purpose grease.

7.3 - GEARS

Gears do not require adjustment but simply periodic greasing. Use purpose grease.

7.4 - SUPPORT FEET

The support feet can deteriorate in time and lose their elasticity, causing loss in stability. To replace contact your local “SERVICE CENTRE”.

7.5 - BLADE

After numerous sharpening and dressing operations check blade diameter. The diameter must not be reduced more than 10 mm in respect to the blade’s original diameter. Contact your local “**SERVICE CENTRE**” for a replacement

7.6 - GRINDERS

Check that the grinders maintain their abrasive property during sharpening. Grinders that are no longer abrasive must be replaced to prevent damaging the blade. Contact your local “**SERVICE CENTRE**” for a replacement.

7.7 - GREASING SLIDING GUIDES

Occasionally put a few drops of oil (from the tube provided) on the round bar the hopper assembly slides back and forth on (Fig. n. 48).

CHAP. 8 – SCRAPPING

8.1 - PUTTING OUT OF SERVICE

For whatever reason you decide to put the slicer out of service, make sure nobody can use it.

8.2 - SCRAPPING

When the slicer is out of service, it can be disposed of. To scrap the slicer contact your local Specialised Waste Treatment Centre, separate components (**refer to chap. 4 par. 4.1**).