

**Warewashing  
 Undercounter, pressure boiler, single  
 skin, drain pump, det&rinse aid  
 dispensers, 540d/h-UK**

ITEM # \_\_\_\_\_

MODEL # \_\_\_\_\_

NAME # \_\_\_\_\_

SIS # \_\_\_\_\_

AIA # \_\_\_\_\_

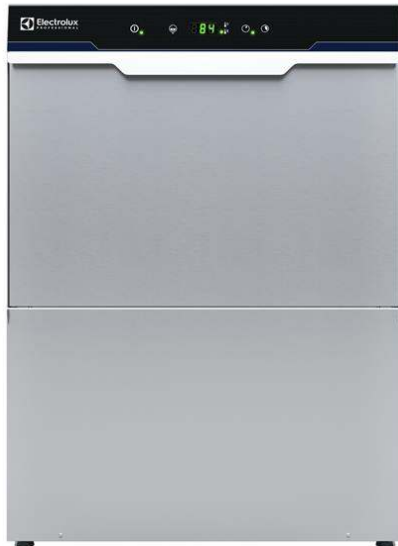
**400206 (ELIG)**

 Undercounter Dishwasher  
 with pressure boiler, single  
 skin, built-in drain pump,  
 detergent and rinse aid  
 dispensers, 1 phase, 540d/h  
 - UK

### Short Form Specification

**Item No.** \_\_\_\_\_

Unit shall be Electrolux Professional undercounter glasswasher type hot water rinsing using rack dimension of 500\*500mm. Electrical characteristics to be 230 volts single phase 50Hz operation. Washing performance is ensure by a powerful wash pump, large capacity wash tank, upper and lower revolving spray arms. Soft start wash pump to avoid accidental breakage of crystal wares. Rinse temperature and pressure guaranteed by built in pressure boiler. Uses 3 liters of clean water per final rinse. Two automatic cycles for different types of wares. Double skin insulated door. 304 AISI stainless steel construction to include door, external panels, frame and wash tank. Electronic control with temperature display. Automatic self-cleaning cycle. The unit shall include drain pump, detergent and rinse aid dispenser pumps and is equipped with electric cable.

### Main Features

- Built-in pressure boiler sized to raise incoming 50 ° C water to guarantee a minimum rinsing temperature of 82 °C for sanitizing rinse. No external booster is required.
- Incorporated Soft Start feature to offer additional protection to more delicate items.
- Washing system endowed with rotating washing arms, high powered wash pump and large capacity boiler for professional washing.
- 4 second (variable) pause after washing and before rinsing ensures that no drops of unclean water will fall on the clean items at the end of the rinsing cycle.
- Fully automatic self-cleaning cycle avoids the risk of bacteria proliferation.
- Simple control panel with digital display allows on-site personalization of washing and rinsing cycle times and temperatures as well as precise rinse aid and detergent quantities to suit customer's needs.
- Simple service from the front.
- IPx4 water protection.
- An effective rinse system uses only 3 liters of clean hot water per basket for lower running costs.
- Digital read-out keeps operator informed as to temperatures.
- State-of-the-art electronic controls with built-in programming, self-diagnostics for serviceability and automatic interior self-cleaning cycle.
- Unique temperature interlock guarantees required temperatures in both the wash and final rinse in case of emergency cold water feeding.
- Washing capacity of 30 baskets or 540 dishes per hour.
- Built-in rinse aid and detergent dispenser with automatic initial and continuous cycle loading for perfect result while minimizing service and maintenance needs.

### Construction

- Unit to feature smooth surfaces to facilitate cleaning.
- Front and side panels, door and wash tank made in heavy duty anti-corrosive AISI 304 stainless steel.
- 304 stainless steel boiler with higher welding protection to increase resistance to corrosion.
- PVC water supply hose with metal connections resistant to high water pressure.
- Completely closed on the back by a cover plate.
- Single phase electrical connection.
- Element protection from dry fire and low water.
- Interchangeable wash/rinse arms screw out for simple clean up.
- The boiler drain facilitates the evacuation of stagnant water after long periods of inactivity to ensure a higher level of hygiene.
- Double skin insulated door to reduce heat dispersion.
- Large wash tank with round corners and no pipes

**APPROVAL:** \_\_\_\_\_

to avoid dirt built-up.

- Incorporated drain pump to control water level in wash tank draining.

### Included Accessories

- 1 of Yellow cutlery container PNC 864242
- 1 of Basket for 48 small cups or 24 cups - blue PNC 867007

### Optional Accessories

- 12lt external manual water softener PNC 860412
- 8lt external automatic water softener PNC 860413
- Stand for undercounter dishwasher PNC 860418
- 20lt external manual water softener PNC 860430
- External detergent level probe kit PNC 864004
- External rinse aid level probe kit PNC 864005
- Kit 4 flanged feet for undercounter dishwashers PNC 864009
- Stainless steel inlet hose kit PNC 864016
- Filter for partial demineralization PNC 864017
- Kit to measure total and partial water hardness PNC 864050
- Rinse booster pump kit for single tank pressure dishwasher PNC 864051
- Stainless steel tank filter for single skin undercounter PNC 864222
- Yellow cutlery container PNC 864242
- Filter for total demineralization PNC 864367
- Pressure reducer for single tank dishwasher PNC 864461
- Connectivity kit for Undercounter Dishwashers and Pot Washers (ECAP) PNC 864479
- Half size basket universal PNC 864527
- Half size basket for plates PNC 864528
- Half size basket for glasses PNC 864529
- Kit 4 plastic boxes for cutlery - yellow PNC 865574
- Basket for 18 dinner plates - yellow PNC 867002
- Basket for 48 small cups or 24 cups - blue PNC 867007
- Cover rack for small and light items (500x500 baskets) PNC 867016
- Basket for 16 vertical glasses (h 70 mm - diam 100 mm) - blue PNC 867023

Front

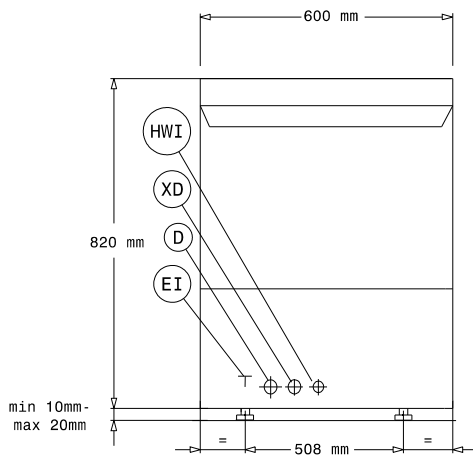

Side

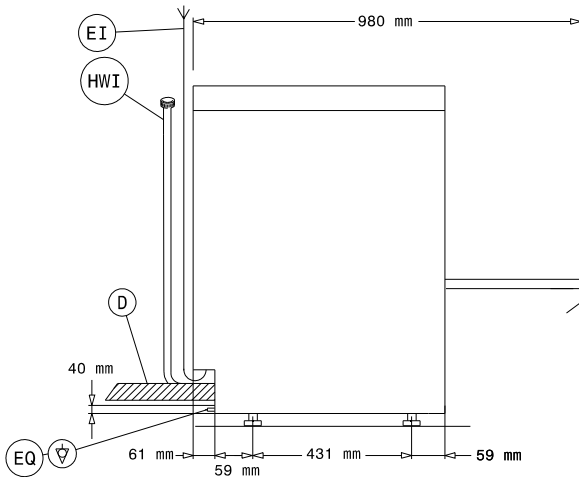

- D = Drain
- EI = Electrical inlet (power)
- EO = Electrical Outlet
- HWI = Hot water inlet
- XD = Detergent connection
- XR = Rinse aid connection

Top

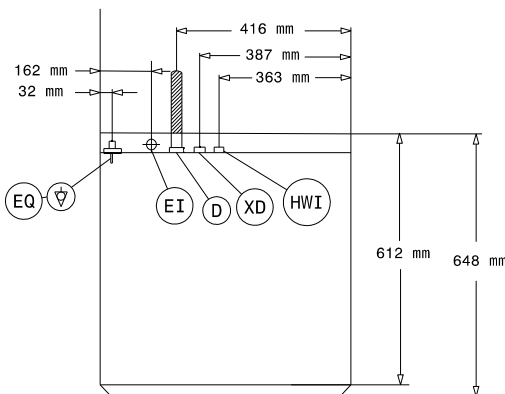

### Electric

<b>Supply voltage:</b>	
400206 (ELIG)	230 V/1 ph/50 Hz
<b>Default Installed Power:</b>	2.85 kW
<b>Boiler heating elements:</b>	1,5 kW
<b>Tank heating elements:</b>	2 kW
<b>Wash pump size:</b>	0.736 kW

### Water:

<b>Pressure, bar min/max:</b>	2-3 bar
<b>Drain line size:</b>	20.5mm
<b>Inlet Water supply pressure:</b>	29 - 44 psi (2 - 3 bar)
<b>Washing tank capacity (lt):</b>	33
<b>Boiler Capacity (lt):</b>	5,8

### Key Information:

<b>Baskets per hour*:</b>	30
<b>Dishes per hour:</b>	540
<b>Working cycles time (sec.):</b>	120/180
<b>Wash temperature:</b>	55-65°C
<b>Cell dimensions - width:</b>	500 mm
<b>Cell dimensions - depth:</b>	500 mm
<b>Cell dimensions - height:</b>	330 mm
<b>Rinse temperature:</b>	80-90 °C
<b>External dimensions, Width:</b>	600 mm
<b>External dimensions, Depth:</b>	648 mm
<b>External dimensions, Height:</b>	820 mm
<b>Packaging size (WxDxH):</b>	740x670x1020 mm

### Sustainability

<b>Water supply temperature*:</b>	50 °C
<b>Water consumption per cycle (lt):</b>	3
<b>Noise level:</b>	<70 dBA