

# SERVICE MANUAL

## GLASSWASHER SINGLE SKIN XS-S

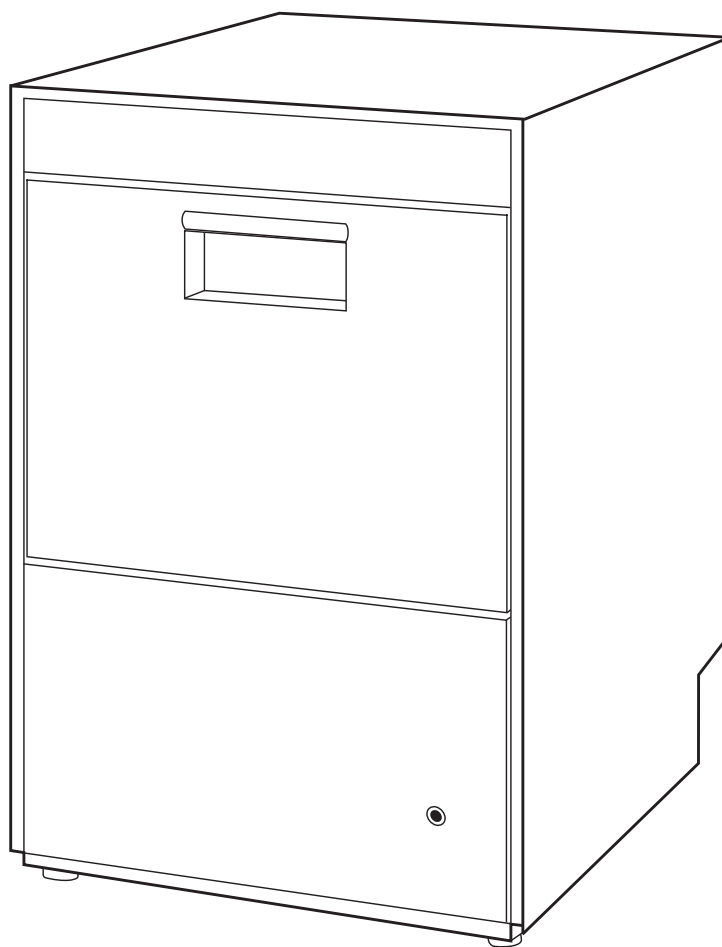

**Document made by Product Care - Technical Training & Service - Vallenoncello PN/Italy**

All the images and information of this document are property of ©Electrolux Professional Spa.  
This document and all of its contents cannot be copied or used, in part or entirely without the written authorization of Electrolux Professional Spa.

©Electrolux Professional Spa. All rights reserved

## REVISIONS UPDATE

EDITION	DESCRIPTION	DATE
01	First publication of this manual	March 2021

## FOREWARD



The service manual (here in after Manual) provides the engineer with information necessary for correct and safe use of the machine (or “appliance”, “machine” or “unit”).

The following must not be considered a long and exacting list of warnings, but rather a set of instructions suitable for improving machine performance in every respect and, above all, preventing injury to persons and animals and damage to property due to improper operating procedures.

All persons involved in machine transport, installation, commissioning, use and maintenance, repair and disassembly must consult and carefully read this manual before carrying out the various operations, in order to avoid wrong and improper actions that could compromise the machine's integrity or endanger people.

If, after reading this manual, there are still doubts regarding machine use, do not hesitate to contact the Manufacturer or the Customer Care to receive prompt and precise assistance for better operation and maximum efficiency of the machine. During all stages of machine assessment, always respect the current regulations on safety, work hygiene and environmental protection. It is the user's responsibility to make sure the machine is started and operated only in optimum conditions of safety for people, animals and property.

## IMPORTANT

- The manufacturer declines any liability for operations carried out on the appliance without respecting the instructions given in this manual.
- The manufacturer reserves the right to modify the appliances presented in this publication without notice.
- No part of this manual may be reproduced without the consent of the manufacturer.
- This manual is available in digital format by:
  - contacting the reference customer care;
  - downloading the latest and up to date manual/technical bulletin(s) on the web site:

<https://www.electroluxprofessional.com>

<https://webgate.electroluxprofessional.com>

**The manual must always be part of the documentation available when servicing the machine.**

## MODELS COVERED BY THE SERVICE MANUAL

MODEL	DESCRIPTION	TYPE	VOLTAGE
EXS	GW (XS), SINGLE SKIN, 30B/H	ELECT.	230V/1N/50Hz
EXSR	GW (XS), SINGLE SKIN, ROUND BASKET, 30B/H	ELECT.	230V/1N/50Hz
EXSP	GW (XS), SINGLE SKIN, DRAIN PUMP, 30B/H	ELECT.	230V/1N/50Hz
EXSG	GW (XS), SINGLE SKIN, DRAIN P., DET. DISP, 30B/H	ELECT.	230V/1N/50Hz
EXSG6	GW (XS), SINGLE SKIN, DRAIN P., DET. DISP, 60HZ, 30B/H	ELECT.	230V/1N/60Hz
ZXS	GW (XS), SINGLE SKIN, 30B/H	ELECT.	230V/1N/50Hz
ZXSP	GW (XS), SINGLE SKIN, DRAIN PUMP, 30B/H	ELECT.	230V/1N/50Hz
ZXSG	GW (XS), SINGLE SKIN, DRAIN P., DET. DISP, 30B/H	ELECT.	230V/1N/50Hz
ZXSG6	GW (XS), SINGLE SKIN, DRAIN P., DET. DISP, 60HZ, 30B/H	ELECT.	230V/1N/60Hz
VXS	GW (XS), SINGLE SKIN, 30B/H	ELECT.	230V/1N/50Hz
VXSG	GW (XS), SINGLE SKIN, DRAIN P., DET. DISP, 30B/H	ELECT.	230V/1N/50Hz
NXS	GW (XS), SINGLE SKIN, 30B/H	ELECT.	230V/1N/50Hz
NXSP	GW (XS), SINGLE SKIN, DRAIN PUMP, 30B/H	ELECT.	230V/1N/50Hz
NXSDU	GW (XS), SINGLE SKIN, DET. DISP, UK PLUG, 30B/H	ELECT.	230V/1N/50Hz
NXSG	GW (XS), SINGLE SKIN, DRAIN P., DET. DISP, 30B/H	ELECT.	230V/1N/50Hz
NXSGU	GW (XS), SINGLE SKIN, DRAIN P., DET. DISP, UK PLUG, 30B/H	ELECT.	230V/1N/50Hz
ES	GW (S), SINGLE SKIN, 30B/H	ELECT.	230V/1N/50Hz
ESP	GW (S), SINGLE SKIN, DRAIN PUMP, 30B/H	ELECT.	230V/1N/50Hz
ESG	GW (S), SINGLE SKIN, DRAIN P., DET. DISP., 30B/H	ELECT.	230V/1N/50Hz
ESGU	GW (S), SINGLE SKIN, DRAIN P., DET. DISP., UK PLUG, 30B/H	ELECT.	230V/1N/50Hz
ESGC	GW (S), SINGLE SKIN, DRAIN P., DET. DISP., COLD RINSE, 30B/H	ELECT.	230V/1N/50Hz
ZS	GW (S), SINGLE SKIN, 30B/H	ELECT.	230V/1N/50Hz
ZSP	GW (S), SINGLE SKIN, DRAIN PUMP, 30B/H	ELECT.	230V/1N/50Hz
ZSG	GW (S), SINGLE SKIN, DRAIN P., DET. DISP., 30B/H	ELECT.	230V/1N/50Hz
ZSGU	GW (S), SINGLE SKIN, DRAIN P., DET. DISP., UK PLUG, 30B/H	ELECT.	230V/1N/50Hz
ZSG6	GW (S), SINGLE SKIN, DRAIN P., DET. DISP., 60HZ, 30B/H	ELECT.	230V/1N/60Hz
ZSGC	GW (S), SINGLE SKIN, DRAIN P., DET. DISP., COLD RINSE, 30B/H	ELECT.	230V/1N/50Hz
VS	GW (S), SINGLE SKIN, 30B/H	ELECT.	230V/1N/50Hz
VSP	GW (S), SINGLE SKIN, DRAIN PUMP, 30B/H	ELECT.	230V/1N/50Hz
VSG	GW (S), SINGLE SKIN, DRAIN P., DET. DISP., 30B/H	ELECT.	230V/1N/50Hz
NS	GW (S), SINGLE SKIN, 30B/H	ELECT.	230V/1N/50Hz
NSP	GW (S), SINGLE SKIN, DRAIN PUMP, 30B/H	ELECT.	230V/1N/50Hz
NSDU	GW (S), SINGLE SKIN, DET. DISP. UK PLUG, 30B/H	ELECT.	230V/1N/50Hz
NSG	GW (S), SINGLE SKIN, DRAIN P., DET. DISP., 30B/H	ELECT.	230V/1N/50Hz
NSGU	GW (S), SINGLE SKIN, DRAIN P., DET. DISP., UK PLUG, 30B/H	ELECT.	230V/1N/50Hz
EMSGBTF	GW (S), SINGLE SKIN, DP, DET. DISP., RBP, TANK FILTER, 30B/H	ELECT.	230V/1N/50Hz

<b>1</b>	<b>GENERAL INFORMATION</b>	<b>6</b>
1.1	MANUAL PURPOSE	6
1.2	SAFETY PRECAUTIONS	6
1.2.1	Personal protection equipment	7
1.3	DATAPLATE	8
1.3.1	Machine and manufacturer's identification data	8
1.3.2	Additional indications	8
1.3.3	How to interpret the factory description	8
1.3.4	How to interpret the serial number	9
1.3.5	Responsibility	9
1.3.6	Copyright	9
1.3.7	Recipients of the manual	9
1.4	EQUIPMENT DESCRIPTION	9
1.4.1	Overall drawings with measurements	9
1.4.2	Main technical data	10
1.4.3	General reference to applicable product certifications	10
<b>2</b>	<b>INSTALLATION AND COMMISSIONING</b>	<b>11</b>
2.1	INSTALLATION	11
2.2	COMMISSIONING	11
2.2.1	Preliminary checks	11
2.2.2	Basic operation to test the machine	11
<b>3</b>	<b>USE OF APPLIANCE</b>	<b>13</b>
3.1	OPERATING INSTRUCTIONS	13
3.2	PREVENTIVE ROUTINES/MAINTENANCE FOR THE OPERATOR	13
3.3	PREVENTIVE MAINTENANCE PLAN (FOR SERVICE): OPERATION FREQUENCY	13
<b>4</b>	<b>CONTROL PANEL</b>	<b>14</b>
<b>5</b>	<b>TROUBLESHOOTING</b>	<b>16</b>
<b>6</b>	<b>SERVICE THE APPLIANCE</b>	<b>19</b>
6.1	LIST OF NEEDED TOOLS	19
6.1.1	Ordinary tools	19
6.1.2	Special tools	19
6.2	REPLACING EQUIPMENT COMPONENTS	19
6.2.1	Components layout	20
6.2.2	Panels	21
6.2.3	Door with hinges	22
6.2.4	Control panel	23
6.2.5	Door switch	24
6.2.6	Pressure switch	25
6.2.7	PCB	26
6.2.8	Tank heating element	27
6.2.9	Inlet water filling valve	28
6.2.10	Boiler heating element	29
6.2.11	Wash pump	30
6.2.12	Drain pump	31
6.2.13	Rinse aid pump	32
6.2.14	Detergent pump	33
6.2.15	Peristaltic hose of detergent pump	34
6.2.16	Thermostats	35
6.2.17	Thermostop	36
<b>7</b>	<b>RELATED DOCUMENTS</b>	<b>37</b>
7.1	ELECTRICAL WIRING DIAGRAM	37
7.2	HYDRAULIC CIRCUITS	37

# 1 GENERAL INFORMATION

## 1.1 MANUAL PURPOSE

The purpose of this manual is to provide useful information for all after-sales operations. In the manual there are some symbols of caution and danger:



**IMPORTANT!** Note of particular importance



**WARNING!** Risk of damage to the machine or the product.



**DANGER!** Danger for the health and safety of operators.



**DANGER!** Danger of electrocution - dangerous voltage.















Read the instructions before using the appliance







Clarifications and explanations

## 1.2 SAFETY PRECAUTIONS

-  **DANGER!** The tasks described in this manual are reserved to specialized personnel, authorized by the Manufacturer who must work while respecting the rules in force in the country of use and the rules as regards facilities and safety at work.
-  **DANGER!** Carefully read all the instructions contained in this manual and in the installation and use manual before every intervention.
-  **DANGER!** This manual should be carefully preserved for future reference.
-  **DANGER!** Always work in perfect physical condition and provided with personal protective tools (e.g. Safety shoes, gloves, glasses etc...)
-  **DANGER!** When working the equipment, make sure in the work area are not present unauthorized persons, flammable or explosive materials and objects that could hinder operations.
-  **DANGER!** Before doing any work on the equipment ALWAYS unplug it from the power supply (danger of fatal electric shock!).
-  **DANGER!** If parts have been replaced, do not leave unattended their packaging (e.g. Plastic bags): choking hazard to children and animals. Packaging must be disposed according to local regulations.

- 
**DANGER!** Interventions, tampering or not expressly authorized changes that do not comply with the instructions in this manual may cause damage, injury or death and will void the warranty.
- 
**DANGER!** When working on the equipment maintain good ventilation in the room.
- 
**DANGER!** After the intervention, before operating the equipment: Make sure to have reassembled correctly all the pieces and any previously disassembled safety devices; Make sure you have correctly connected the device to the mains; Instruct the operator on any possible new device on the machine.
- 
**DANGER!** The surfaces become hot during use and remain hot for some time after the equipment has been switched off: Any maintenance is therefore to be executed after the equipment has been fully cooled.
- 
**WARNING!** Some parts have sharp inner edges: always use gloves.

## 1.2.1 PERSONAL PROTECTION EQUIPMENT

Stage	Protective garments	Safety footwear	Gloves	Glasses	Safety helmet
					
Transport	—	•	○	—	○
Handling	•	•	○	—	—
Unpacking	○	•	○	—	—
Installation	○	•	● <sup>1</sup>	—	—
Normal use	•	•	● <sup>2</sup>	○	—
Adjustments	○	•	—	—	—
Routine cleaning	○	•	● <sup>1,3</sup>	○	—
Extraordinary cleaning	○	•	● <sup>1,3</sup>	○	—
Maintenance	○	•	○	—	—
Dismantling	○	•	○	○	—
Scrapping	○	•	○	○	—
Key:					
•	PPE REQUIRED				
○	PPE AVAILABLE OR TO BE USED IF NECESSARY				
—	PPE NOT REQUIRED				
1.	During these operations, gloves must be cut-resistant. Failure to use the personal protection equipment by operators, specialized personnel or users can involve exposure to damage to health (depending on the model).				
2.	During these operations, gloves must be heatproof and suitable for contact with water and the substances used (refer to the safety data sheet of the substances used for the information regarding the required PPE). Failure to use the personal protection equipment by operators, specialized personnel or users can involve exposure to chemical risk and cause possible damage to health (depending on the model).				
3.	During these operations, gloves must be suitable for contact with chemical substances used (refer to the safety data sheet of the substances used for information regarding the required PPE). Failure to use the personal protection equipment by operators, specialized personnel or users can involve exposure to chemical risk and cause possible damage to health (depending on the model).				

## 1.3 DATAPLATE

### 1.3.1 MACHINE AND MANUFACTURER'S IDENTIFICATION DATA

An example of the marking or data plate on the machine is given below:

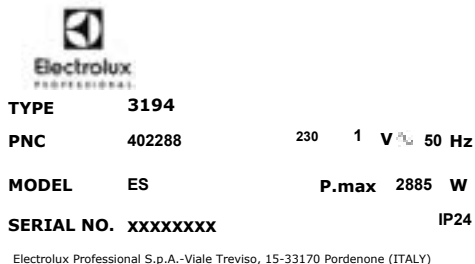

The data plate gives the product identification and technical data. The meaning of the various information given on it is listed below:

F.Mod.	factory description of product
Comm.Model	commercial description
PNC	production number code
Ser.Nr.	serial number
V	power supply voltage
Hz	power supply frequency
kW	max. power input
Type ref.	list of acronyms used to identify the type of machine, uniquely
CE	CE marking
IPX5	dust and water protection rating
Electrolux Professional SpA Viale Treviso 15 33170 Pordenone Italy	manufacturer

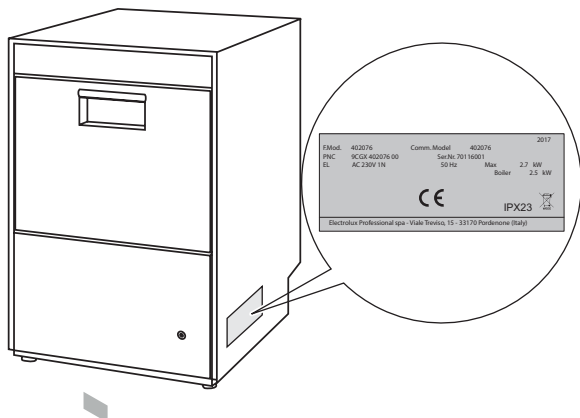

Fig. 1 Data plate position (machine right)

The main dataplate information can be viewed accessing the Service menu. Please refer to chapter §4.4.15.1 Dataplate.



### IMPORTANT

When installing the machine, make sure the electrical connection is carried out in compliance with that specified on the data plate.



### NOTE!

Refer to the data given on the machine's data plate for relations with the Manufacturer (e.g. when ordering spare parts, etc.).

### 1.3.2 ADDITIONAL INDICATIONS

The drawings and diagrams given in the manual are not in scale. They supplement the written information with an outline, but are not intended to be a detailed representation of the machine supplied. The numerical values given on the machine installation diagrams refer to measurements in millimeters and/or inches. Conventionally, the machine are depicted with the rack feed side on the right ("R"); machine with left rack feed ("L") are depicted only if necessary, in which case the side will be expressly specified. Due to its size, the machine is sometimes shown schematically divided into its functional modules in order to provide a complete view.

### 1.3.3 HOW TO INTERPRET THE FACTORY DESCRIPTION

The factory description on the data plate has the following meaning:

(1)	(2)	(3)	(4)	(5)
E	XS	P	-	-
E	S	G	U	-
E	MS	G	B	TF
Z	XS	G	6	
V	S	G	-	-

	Description	Possible variables
(1)	Brand	E=Electrolux, Z=Zanussi, V= Veetsan/Veetsan Star N= To Brand
(2)	Size	XS (GW 380x380mm racks) S (GW 400x400mm racks) MS (GW 450x450mm racks)
(3)..(5)	Features	C=Cold rinse D=Detergent dispenser P=Drain Pump G= Drain pump + Detergent dispenser B=Booster pump UK= Uk plug TF=Tank filter R=Round vasket 6 = 60Hz



## 1.3.4 HOW TO INTERPRET THE SERIAL NUMBER

The Serial Number on the data plate uniquely identifies:

- The year of construction of the appliance;
- The week of construction of the appliance;
- The progressive number of construction.

### EXAMPLE:

Serial Number **91610002**

<b>9</b>	4th digit of the year of construction
<b>16</b>	Week of construction
<b>1</b>	3th digit of the year of construction
<b>0002</b>	construction sequential number

In this case, the appliance is the second (**0002**) machine built in week **16** of the year **2019**.

**The Serial Number is necessary to find the correct spare part in the spare parts catalogue and it is mandatory to ask technical support from the Manufacturer.**

## 1.3.5 RESPONSIBILITY

**The Manufacturer declines any liability for damage and malfunctioning caused by:**

- non-compliance with the instructions contained in this manual;
- repairs not carried out in a workmanlike fashion, and replacements with parts different from those specified in the spare parts catalogue (the fitting and use of non-original spare parts and accessories can negatively affect machine operation and invalidates the warranty);
- operations by non-specialised technicians;
- unauthorised modifications or operations;
- inadequate maintenance;
- improper machine use;
- unforeseeable extraordinary events;
- use of the machine by uninformed and untrained personnel;

## 1.3.6 COPYRIGHT

This manual is intended solely for consultation by the operator and can only be given to third parties with the permission of Electrolux Professional SpA.

## 1.3.7 RECIPIENTS OF THE MANUAL

This manual is intended for:

- specialised technicians - after-sales service

## 1.4 EQUIPMENT DESCRIPTION

The dishwasher is a glasswasher type with hot water rinsing for rack dimension of 380x380mm, 400\*400mm, 450x450mm.

The glasswasher is suitable for washing glasses, cups, cutlery. Under no circumstances it can be used for other applications or ways not provided for in this manual.

This equipment has been created in order to ensure a better work environment and cost efficiency.

These dishwashers are used in restaurants, cafeterias, cooking centers and large institutions. The special dish racks, that can be equipped with various inserts, offer practical and easy use for obtaining excellent wash-ing results.

The built-in pressure boiler is designed to raise incoming water to a guaranteed minimum temperature of 82°C for sanitizing rinse. No external boiler is required. Washing system is endowed with ro-tating washing arms from both top and bottom; high powered wash pump and large capacity wash tank guarantee professional washing. One wash cycle of 120 seconds.

The glasswasher is equipped with single phase electrical cable and Schuko or UK plug for easy and fast installation; the rinse aid dispenser is included; detergent pump and drain pump are accessories or built-in according to the model.

**Tab. 1 – Connections**

Water inlet		Ø	3/4" G
Recommended water pressure [Model equipped with rinse booster pump]		bar	1.8-3.0 [1.0-3.0]
Drain pipe [De.]	without drain pump	mm	22
	with drain pump	mm	27
Electrical connection		V/P/Hz	230/1N/50 230/1N/60

### 1.4.1 OVERALL DRAWINGS WITH MEASUREMENTS

Please, refer to the Installation manual available on the website:

<https://www.electroluxprofessional.com> or <https://webgate.electroluxprofessional.com>

## 1.4.2 MAIN TECHNICAL DATA

Model		(E-Z-V-N)XS, S .. R, P, G, GC	(E-Z)XS, S ..G6	(E-Z-N)XS, S ..DU, GU
Voltage:	V	230/1N	230/1N	230/1N
Frequency	Hz	50	60	50
Maximum power input	kW	2.89	2.89	2.89
Boiler heating power	kW	2.70	2.70	2.70
Tank heating element	kW	2.40	2.40	2.40
Wash Pump	kW	0.19	0.19	0.19
Drain Pump (P model)	kW	0.025	0.025	0.025
Rinse Booster Pump	kW	–	–	–
Supply water pressure	kPa [bar]	200 – 500 [2.0 – 5.0]	200 – 500 [2.0 – 5.0]	200 – 500 [2.0 – 5.0]
Supply water temperature	°C [°F]	50 [122]	50 [122]	50 [122]
Water hardness	°fH[dH]	14[8] Maximum	14[8] Maximum	14[8] Maximum
Concentration of chlorides in water	ppm	<20	<20	<20
Water conductivity	µS/cm	< 400	< 400	< 400
Rinse water consumption	L/cycle	2.0	2.0	2.0
Boiler capacity	Lit	3	3	3
Tank capacit XS model	Lit.	10	10	10
Tank capacit S model	Lit.	12	12	12
Duration of standard cycles with supply water at 50°C	Sec.	120	120	120
Legal noise level	dB (A)	LpA 67.5dB, KpA 1.5dB (*)		
Protection level		IP24		
Net weight	kg	min 33 - max 38	min 33 - max 38	min 33 - max 38
Power cable type		H07RN-F – Schuko plug	H07RN-F – No plug	H07RN-F – UK plug

(\*) = The noise emission values have been obtained according to EN ISO 11204.



**CAUTION!** For all the additional modules installed later, make sure that the power cable supply is properly sized.

### Characteristics of power supply

The AC power supply to the machine must meet the following conditions:

- max. voltage variation  $\pm 6\%$
- max. frequency variation  $\pm 1\%$  continuous  $\pm 2\%$  for a short period.

Harmonic distortion, unbalanced three-phase supply voltage, voltage pulses, interruption, dips and the other electric characteristics must respect the provisions of point 4.3.2 of Standard EN 60204-1 (IEC 60204-1).

## 1.4.3 GENERAL REFERENCE TO APPLICABLE PRODUCT CERTIFICATIONS

Please, for overall certifications refer to Conformity Certificate and Conformity Declaration available on website:

<https://www.electroluxprofessional.com> or <https://webgate.electroluxprofessional.com>

## 2 INSTALLATION AND COMMISSIONING

### 2.1 INSTALLATION

Please, for installation refer to Installation Manual available on website <https://www.electroluxprofessional.com> or <https://webgate.electroluxprofessional.com>

### 2.2 COMMISSIONING

To avoid accidents, when debugging the machine please pay special attention to the following:

- The debugging can only be carried out by professional service partner;
- Please check the installation tools and other items are all removed in initial start;
- Check for possible water and chemical leakage;
- Check if the security system and door switch are normal when debugging
- Check that all screws are tightened.

When the installer completes all installation work and all the settings work, the machine can start running.

Please, for commissioning refer to Commissioning and preventive maintenance checklist available on website <https://www.electroluxprofessional.com> or <https://webgate.electroluxprofessional.com>

#### 2.2.1 PRELIMINARY CHECKS

A function check must be made when the installation is finished and before the machine can be ready to be used.

Whenever a repair has been made, a function check must be performed before the machine can be used again.

##### Identify the equipment on data plate:

- Model
- PNC
- S/N

A function check must be made when the installation is finished and before the machine can be ready to be used. Whenever a repair has been made, a function check must be performed before the machine can be used again.

##### Check the interior

Open the door, make sure that all parts are placed in correct location.

Make sure that there are no irrelevant parts inside the machine (for example: hanging cloth, screws, nuts, tools, packaging materials, etc.).

##### Water inlet hose

Please clean the inlet hose before connection. Before initial water feeding, please disconnect all heater and power supply to avoid heating with no feeding water.

##### Water supply connection and related flow pressure

Check if the inlet hose is connected firmly, as looseness and leakage may happen in transporting and car-rying process. Related non-standard flow pressure can lead to faults of the machine.

##### Electrical Connection

Connect the mains plug to the mains socket only at the end of the installation. Make a visual test for all the electrical equipment if they are in good condition, (for example: switches, cables, motor shell, etc.), and test all the functions of power switch.

##### Check the automatic stop of the machine

Start the machine and check if the micro switch is working properly: the machine must stop if the door is opened.

##### Ready to use

If all tests are OK the machine is now ready to be used. If some of t

#### 2.2.2 BASIC OPERATION TO TEST THE MACHINE

<p>1. Preliminary checks</p>	<p>1. Water analyses and power supply.</p>	<p>1. Using the special tools indicated in chapter 6.1.2 Special tools, perform the following water analyses:</p> <ul style="list-style-type: none"> <li>- Total water hardness;</li> <li>- Temporary water hardness;</li> <li>- Water inlet pressure;</li> <li>- Water inlet temperature;</li> <li>- pH;</li> <li>- Conductivity;</li> <li>- ppm;</li> <li>- Chloride;</li> </ul> <p>In case of water treatment for feeding water (water softener or reverse osmosis) consider to perform the water analyses even upstream the of water treatment.</p> <p>Water quality affects the dosage of detergent and rinse aid.</p> <p><b>It is strongly recommended Electrolux Professional C11 or C13 Detergent aid.</b></p> <p><b>It is strongly recommended Electrolux Professional C12 or C14 Rinse aid.</b></p> <p>2. Check socket power supply is according to value requested by the appliance</p>
------------------------------	--	--

	2. Components fitting check	Make sure the overflow, the tank filter the upper and lower wash arms and the upper and lower rinse arms are correctly fitted.
2. Ensure that the machine water incoming, heating program operates normally.	Open the water supply main tap, connect the plug, close the machine power switch B1; power indication light H1 is on.	1. Observe if the water flows into boiler. - if there is sounds of water flow. - check electromagnetic valves for inletting/rinsing is open: (place screwdriver to the coil, if there is magnetic attraction means the valves are con-nected to power, there is no water passing, or it is broken or the pipe are blocked, the water source are not open). - wait few minutes to see if the water is flowing into tank and spray through the rinse arms->that means the boiler is full.
		2. Open and close the door to check if door switch operates correctly stopping the fill-ing valve.
		3. When the water reaches the right level, the pressure switch P1 diverts the contact to power the boiler heating element. When the temperature in the boiler is reached, the boiler thermostat diverts the contact to power the tank heating element.
		4. Check if the piping system, tank, boilers are leaking.
		5. When the indication light H3 is on, the tank has reached the correct temperature and the appliance is ready to be used.
3. Make sure washing rinsing, cold rinsing and draining operate properly.	1. Start a washing cycle when the appliance is ready to be used.	1. Press start button B4 for 2 seconds. 2. Observe indication light H2 is on
	2. Calibration of the dispensers	The concentration of detergent/rinse aid depends on the type of product used and the hardness of the supply water (check the characteristics on the product label). 1. Rinse aid dispenser adjustment: Upon first installation, it may be necessary to activate the dispenser in the following way: • Loosen the adjustment screw until it stops; • press the screw in until the rinse-aid has filled the tube. To vary the rinse aid dose, adjust the adjustment screw on the peristaltics pump. To check the efficiency of the rinse aid look at a freshly washed glass. Drops of water on the glass indicate an insufficient dosage while streaks indicate an excessive dosage which can either be caused by the density or the quantity. <b>It is strongly recommended Electrolux Professional C12 or C14 Rinse aid.</b> 2. Detergent aid dispenser adjustment: Adjust the screw "L" shaped to set the required dose. The adjustment of the amount of detergent delivered by the pump must carefully comply with that indicated by the de-tergent producer. <b>It is strongly recommended Electrolux Professional C11 or C13 Detergent aid</b>
	3. Start the manual cold rinse	Press cold rinse button S3 and hold it pressed for 30 seconds. 1) Observe if there is sounds of water flow. 2) Check electromagnetic valve for cold rinse is open: (place screwdriver to the coil, if there is magnetic attraction means the valves are con-nected to power, there is no water passing, or it is broken or the pipe are blocked, the water source are not open). 3) Check if booster pump is enabled.
	4. Start the manual drain	If the appliance is equipped with drain pump: Press drain button S1 to enable the drain pump. Hold the button until a gurgling sound can be heard, indicating that the tank has emptied. Open the door at last to avoid ap-pliance re-starts the warmup.

## 3 USE OF APPLIANCE

### 3.1 OPERATING INSTRUCTIONS

Please refer to the User Manual of the appliance available on website <https://www.electroluxprofessional.com> or <https://webgate.electroluxprofessional.com>  
In case of any doubt, refer to your local country Customer Care.

### 3.2 PREVENTIVE ROUTINES/MAINTENANCE FOR THE OPERATOR

Please refer to the User Manual of the appliance available on website <https://www.electroluxprofessional.com> or <https://webgate.electroluxprofessional.com>  
In case of any doubt, refer to your local country Customer Care.

### 3.3 PREVENTIVE MAINTENANCE PLAN (FOR SERVICE): OPERATION FREQUENCY

Please refer to the PREVENTIVE MAINTENANCE PLAN  
Please, for the Preventive Maintenance Plan refer to Commissioning and preventive maintenance checklist available on website: <https://www.electroluxprofessional.com> or <https://webgate.electroluxprofessional.com>  
In case of any doubt, refer to your local country Customer Care.

Instructions for accessing and replacing components in accordance with PREVENTIVE MAINTENANCE PLAN are given in chapter 6 SERVICE THE APPLIANCE.

At the first installation or after long idle periods it is advisable to manually rotate the wash pump impeller to free it from possibly adhering.

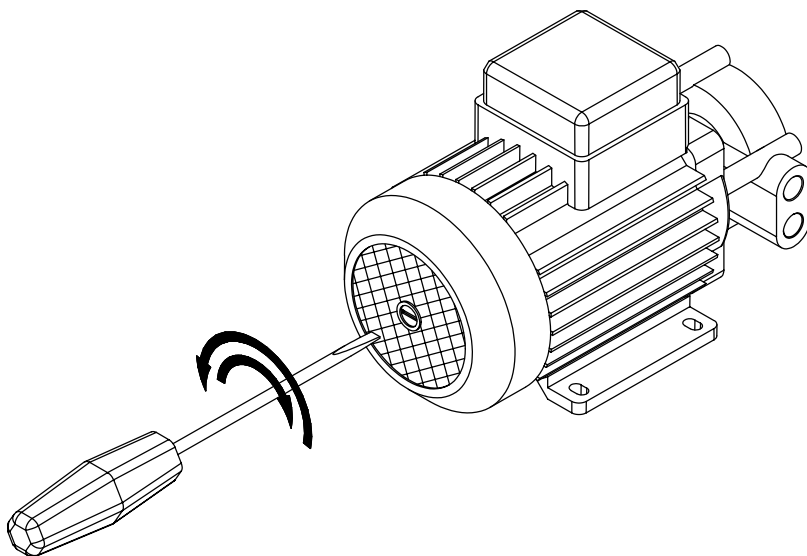

## 4 CONTROL PANEL

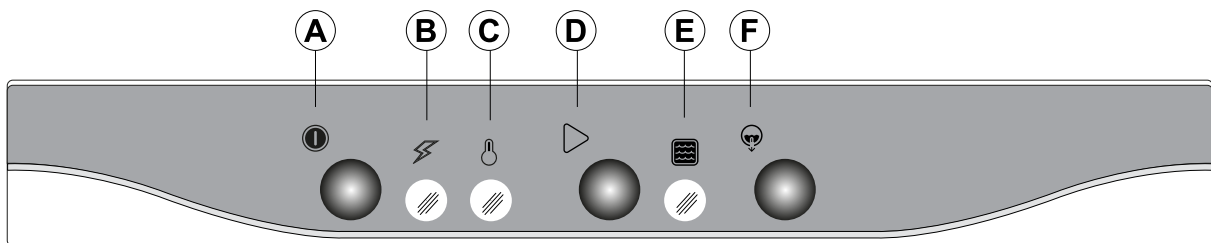
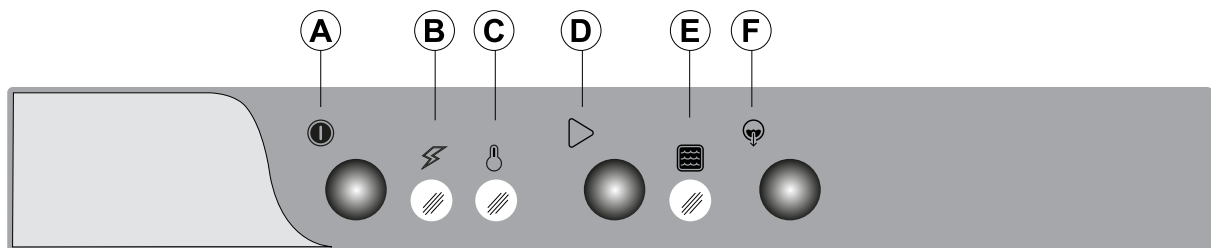
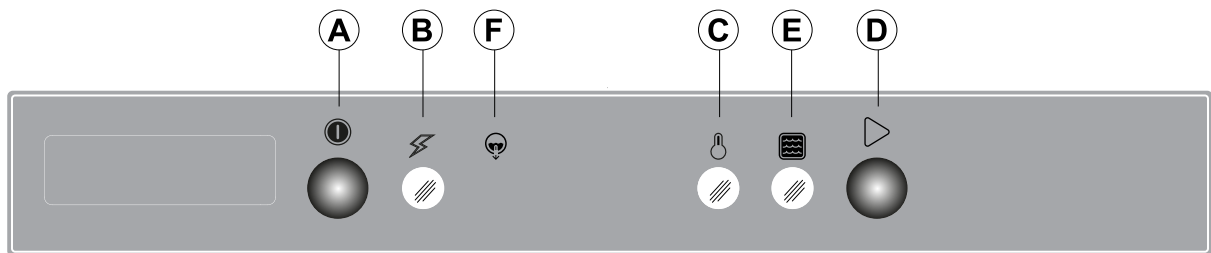
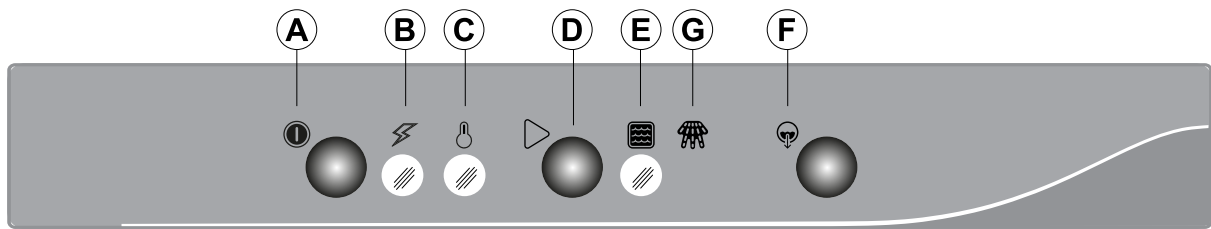
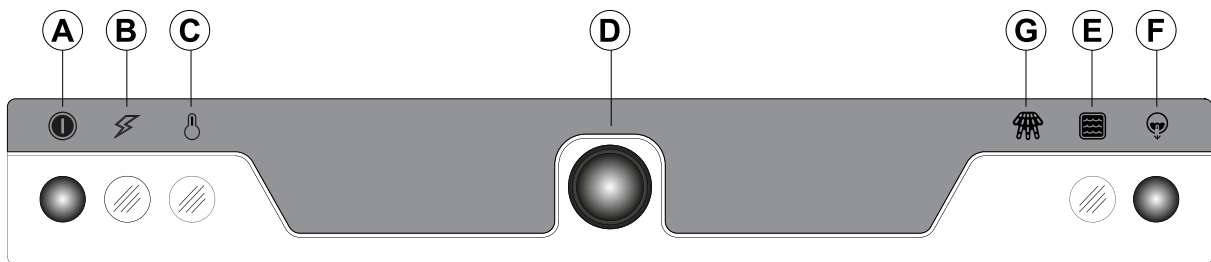

### Legend

A = ON/OFF button

B = ON indicator

C = Water temperature indicator

D = START button

E = Wash cycle indicator

F = Drain button

G = Cold Rinse button

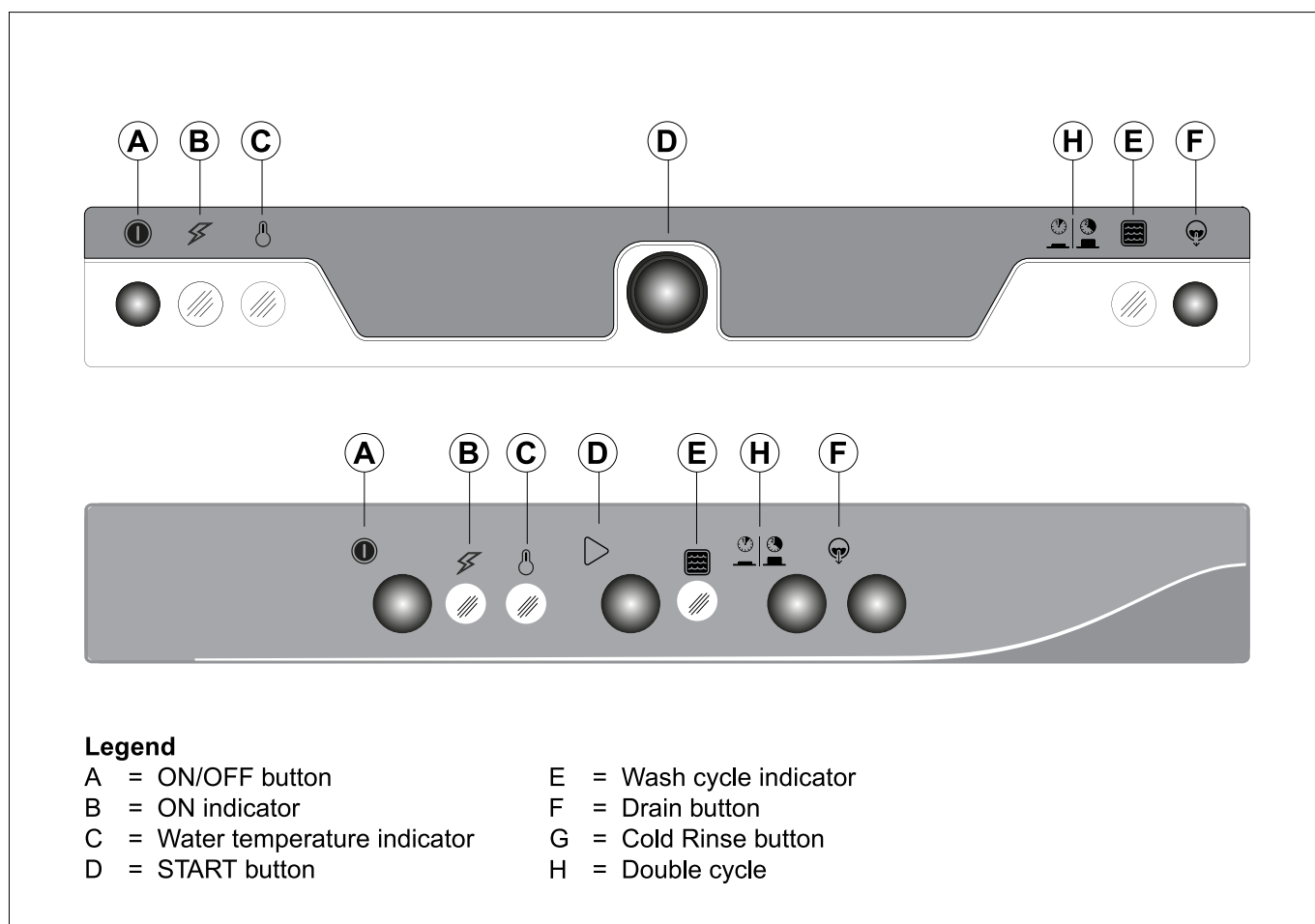

### ON/OFF button (A)

Press this button to activate the appliance. Press it again to deactivate.

### ON indicator (B)

when the appliance is on, the B indicator is lit up.

### Water temperature indicator (C)

When the water in the tank and boiler reach the operating temperature, the C indicator is lit up.

### START button (D)

This button starts washing cycle.

This cycle is recommended for washing normally dirty dishes.

### Wash cycle indicator (E)

This indicator is on, when you start the washing cycle.

It is off, when the washing cycle is finished.

### Drain/button (F)

Press this button to start the drain/cycle. When the cycle is selected, the button indicator is lit up.

This option is available only in the models with drain pump.

### Cold rinse button (G)

At the end of the wash cycle, press this button to start the cold rinse cycle.

Particularly suitable for rinsing glasses. The duration of the cold rinse cycle is related to how much time the same button is pressed.

## 5 TROUBLESHOOTING

The general troubleshooting is referred to general issues that affect the function and the performance of the appliance, and the washing results. these problems cannot be detected by the machine diagnostics system.

N.	Anomaly	Type of Anomaly	General description	Possible cause	Instruction to User	Service Action
1	Glasswasher does not switch on	Machine blocked	ON/OFF Button is pressed.	1) Tripped circuit breaker of power supply, 2) Machine not properly supplied; 3) PCB board faulty	1) Switch on the circuit breaker in the main electrical box, 2) Please call Service Center, 3) Please call Service Center.	2) Check supply voltage on the main terminal: if it is wrong, alert the customer it could be a failure of its electrical network breakdown; 3) Replace PCB board.
2	Glasswasher doesn't fill water in the tank	Machine blocked	ON indicator lamp lighted up. The dishwasher doesn't start fill water in the tank.	1) Door not closed; 2) Water tap of the main water net supply closed; 3) The filter of the inlet water valve is dirty; 4) Low Pressure from the water net supply; 5) Overflow pipe not inserted, or not correctly inserted; 6) The gasket on the overflow pipe is missing/broken; 7) Water supply hose throttled; 8) Door microswitch faulty; 9) Filling valve faulty; 10) PCB board faulty.	1) Close the door of the glasswasher; 2) Open the main water tap; 3) Please call Service Center 4) Check the water pressure of the main water tap. It has to be 2.0 bar at least; 5) Check the overflow pipe and insert it correctly in the tank, 6) Replace the gasket. In case, call Service Center to provide a new spare, 7) Fix up the hose path. In case, call Service Center to replace the hose; 8) Please call Service Center, 9) Please call Service Center; 10) Please call Service Center.	3) Clean the valve filter; 5) Replace the hose for the water inlet, 6) Provide de spare; 7) Provide the spare, 8) Replace door micro switch, 9) Replace the filling valve, 10) Replace PCB board..
3	Glasswasher detects door open when the door is closed.	Machine blocked.	Wash cycle indicator slow blink.	1) Door switch faulty; 2) Door magnet lost/ broken; 3) PCB board faulty.	Please call Service Center	1) Replace the door switch, 2) Replace the magnet, 3) Replace PCB board..
4	Glasswasher is ready but does not start the washing cycle after press start button	Machine blocked	Machine is ready but not start after pressing start button	1) PCB board faulty.	Please call Service Center	1) Replace PCB board.
5	Glasswasher is in run mode but does not start the washing cycle after press start button	Machine blocked	Machine cycle indicator lighted up but wash pump doesn't run	1) PCB faulty; 2) Over temperature wash pump; 3) Capacitor faulty; 4) Wash pump blocked/ obstructed; 5) Wash pump blocked.	Please call Service Center	1) Replace PCB; 2) Wait the pump cooling and check the pump bearing and/or capacitor; 3) Replace the capacitor; 4) Dismantle the pump and check inside the pump scroll; 5) Try to unlock the pump with a screwdriver through the hole provided.
6	Dishes / Glasses not cleaned	Loss of performance	Dirt and food residues on the surface of dishes/ glasses.	1) No scrape action before putting the rack in the glasswasher; 2) Dishwasher is running with-out detergent-aid; 3) Tank filter of machine is not correctly fitted or missing; 4) Wash/rinse arms nozzles clogged; 5) Detergent pump worn; 6) Detergent pump faulty; 7) Wash water temperature not correct; 8) Boiler water temperature not correct.	1) Scrape dishes/glasses before putting them in the basket, 2) Check the level of detergent aid in the can. In case replace it with a new one. <b>It's strongly suggested Electrolux Professional C11 or C13 Detergent aid,</b> 3) Position the tank filter properly; 4) Clean wash/rinse arms. In case of descaling, please call Service center; 5) Please call the service center for chemical products and dispensers; 6) Please call the service center for chemical products and dispensers; 7) Please call Service Center; 8) Please call Service Center.	4) Soaking the Wash/Rinse arms in a solution of water and descale product, It is strongly suggested Electrolux Professional Delime away C30; 5) Replace the peristaltic hose in the detergent pump. 6) Replace the detergent pump, 7) Adjust the temperature in the tank thermostat switch, 8) Adjust the temperature in the boiler thermostat switch.



# SERVICE MANUAL

N.	Anomaly	Type of Anomaly	General description	Possible cause	Instruction to User	Service Action
7	Stained glasses and dishes	Loss of performance	Glasses and/or dishes not cleaned	<ol style="list-style-type: none"> <li>1) Foam in wash tank;</li> <li>2) Check the correct chemical products pipes in the right can;</li> <li>3) Check the detergent dose rate;</li> <li>4) Check the tank filter if dirty;</li> <li>5) Wash water temperature not correct;</li> <li>6) Dirty nozzles;</li> <li>7) Lack of the final rinse</li> </ol>	<ol style="list-style-type: none"> <li>1) Only use not-foaming products for professional dishwashers. It is strongly suggested Electro-lux Professional C11 or C13 Detergent aid and C12 or C14 Rinse aid;</li> <li>2) Place blue pipe in the rinse aid can and the transparent in the detergent can;</li> <li>3) Please call Service Center.</li> <li>4) Remove the plastic filter in the tank and clean it properly;</li> <li>5) Please call Service Center.</li> <li>6) Remove the wash/rinse arms and clean the nozzles properly;</li> <li>7) Check the final rinse</li> </ol>	<ol style="list-style-type: none"> <li>3) Adjust the amount of detergent and rinse aid products;</li> <li>5) Adjust the temperature in the tank thermostat switch;</li> <li>7) Check the inlet water valve and the water net pressure</li> </ol>
8	Condensation on glasses	Loss of performance	Moisture deposit-ed on the glasses surface	<ol style="list-style-type: none"> <li>1) Dishwasher is running without rinse-aid;</li> <li>2) Rinse-aid pump faulty</li> </ol>	<ol style="list-style-type: none"> <li>1) Check if that there is rinse-aid in the can and in case top up or change it. <b>It is strongly suggested Electrolux Professional C12 or C14 Rinse aid;</b></li> <li>2) Please call Service Center.</li> </ol>	<ol style="list-style-type: none"> <li>2) Replace rinse aid pump.</li> </ol>
9	Smears or spots on the glasses	Loss of performance	Smears or spots on the glasses	<ol style="list-style-type: none"> <li>1) Excessive dosage of rinse-aid;</li> <li>2) Rinse-aid pump faulty;</li> <li>3) Excessive dosage of the detergent;</li> <li>4) Water hardness too high</li> </ol>	Please call Service Center	<ol style="list-style-type: none"> <li>1) Reduce the amount of rinse-aid;</li> <li>2) Replace rinse aid pump;</li> <li>3) Reduce the amount of the detergent;</li> <li>4) Suggest to install a water treatment</li> </ol>
10	Glasses and dishes are not dried properly	Loss of performance	Water drops deposited on the glasses/dishes surface	<ol style="list-style-type: none"> <li>1) Dishwasher is running without rinse-aid;</li> <li>2) Rinse-aid pump faulty;</li> <li>3) Water rinse temperature too low.</li> </ol>	<ol style="list-style-type: none"> <li>1) Check that there is rinse-aid in the can and in case top up or change. <b>It is strongly suggested Electrolux Professional C12 or C14 Rinse aid;</b></li> <li>2) Please call Service Center;</li> <li>3) Please call Service Center.</li> </ol>	<ol style="list-style-type: none"> <li>2) Replace rinse aid pump;</li> <li>3) Adjust the temperature in the boiler thermostat switch.</li> </ol>
11	Excessive foam in the tank	Loss of performance	Presence of foam in the tank	<ol style="list-style-type: none"> <li>1) Residuals of food or detergent used for manual scraping;</li> <li>2) Excessive dosage of rinse-aid;</li> <li>3) Wash water temperature not correct</li> </ol>	<ol style="list-style-type: none"> <li>1) Check if the tank has cleaned with unsuitable cleaners. In case empty the tank and carefully rinse before resuming work. If a foaming detergent has used, empty and refill the tank with water until the foam is remove;</li> <li>2) Please call Service Center;</li> <li>3) Please call Service Center.</li> </ol>	<ol style="list-style-type: none"> <li>1) Make sure that the customer is using suitable cleaners;</li> <li>2) Reduce the amount of rinse-aid;</li> <li>3) Adjust the temperature in the tank thermostat switch. Check the tank heating element</li> </ol>
12	Loss of water pressure from wash arms	Loss of performance	Crockery not cleaned	<ol style="list-style-type: none"> <li>1) Tank filter dirty;</li> <li>2) Wash arms clogged;</li> <li>3) Obstruction in the pipe inlet/outlet of wash pump;</li> <li>4) Wash pump clogged.</li> </ol>	<ol style="list-style-type: none"> <li>1) Remove and clean the tank filter;</li> <li>2) Remove and clean the wash arms;</li> <li>3) Please call Service Center;</li> <li>4) Please call Service Center</li> </ol>	<ol style="list-style-type: none"> <li>3) Uninstall the inlet and outlet hoses of the pump and check if they are clogged: in case clean the hoses;</li> <li>4) Uninstall the wash pump and check if the impeller is clogged: in case clean the impeller.</li> </ol>
13	Loss of water pressure from rinse arm	Loss of performance	Crockery not rinsed	<ol style="list-style-type: none"> <li>1) Rinse arms clogged;</li> <li>2) Filling water filter clogged;</li> <li>3) Filling valve faulty;</li> <li>4) Safety valve broken</li> </ol>	<ol style="list-style-type: none"> <li>1) Remove and clean the rinse arms;</li> <li>2) Please call Service Center;</li> <li>3) Please call Service Center;</li> <li>4) Please call service Center.</li> </ol>	<ol style="list-style-type: none"> <li>2) Remove the valve filter and clean it;</li> <li>3) Replace the filling valve;</li> <li>4) Check/replace the safety valve in the wall-mounted tank.</li> </ol>
14	The machine is off but it still fills water in the tank	Loss of performance	Glasswasher is off but does not stop rinsing/filling	<ol style="list-style-type: none"> <li>1) Filling valve faulty;</li> <li>2) Cold rinse valve faulty.</li> </ol>	Please call Service Center	<ol style="list-style-type: none"> <li>1) Replace the filling valve;</li> <li>2) Replace the cold rinse valve.</li> </ol>
15	Cold rinse cycle doesn't run	Loss of performance	After the cold rinse cycle crockeries are still hot	<ol style="list-style-type: none"> <li>1) Cold rinse switch not pressed;</li> <li>2) Machine connected to hot water supply;</li> <li>3) Cold rinse valve dirty;</li> <li>4) Cold rinse valve faulty;</li> <li>5) PCB board faulty.</li> </ol>	<ol style="list-style-type: none"> <li>1) Press the cold rinse switch;</li> <li>2) Please call Service Center;</li> <li>3) Please call Service Center;</li> <li>4) Please call Service Center;</li> <li>5) Please call Service Center</li> </ol>	<ol style="list-style-type: none"> <li>2) Connect the machine to cold water supply;</li> <li>3) Remove and clean the cold rinse valve;</li> <li>4) Replace the cold rinse valve;</li> <li>5) Replace PCB board.</li> </ol>
16	Wash pump out of order	Machine blocked	Wash arms don't spray water	<ol style="list-style-type: none"> <li>1) Pump blocked;</li> <li>2) Wash pump clogged;</li> <li>3) Pump capacitor faulty;</li> <li>4) Wash pump faulty;</li> <li>5) PCB board faulty</li> </ol>	Please call Service Center	<ol style="list-style-type: none"> <li>1) Try to unlock the pump with a screwdriver though the hole provided;</li> <li>2) Remove and clean the wash pump;</li> <li>3) Replace the pump capacitor;</li> <li>4) Replace the wash pump;</li> <li>5) Replace PCB board</li> </ol>

N.	Anomaly	Type of Anomaly	General description	Possible cause	Instruction to User	Service Action
17	Drain pump out of order	Loss of performance	Glasswasher cannot be emptied	1) Drain pump clogged; 2) Drain pump faulty; 3) PCB board faulty.	Please call Service Center	1) Remove and clean the drain pump; 2) Replace the drain pump; 3) Replace PCB board.
18	Wash Cycle Indicator slow blinking	Machine blocked	Door open	1) Door switch faulty; 2) Door magnet; lost/broken; 3) PCB board faulty.	Please call Service Center	1) Replace the door switch; 2) Replace the magnet; 3) Replace PCB board.
19	Wash Cycle Indicator fast blinking	Machine blocked	Water filling	1) Water tap of the main water net supply closed; 2) The filter of the inlet water valve is dirty; 3) Low pressure from the water net supply; 4) Overflow pipe not inserted, or not correctly inserted; 5) The gasket on the overflow pipe is missing/broken; 6) Water supply hose throttled; 7) Pressure switch faulty; 8) Air gap circuit faulty; 9) Filling valve faulty; 10) PCB board faulty.	1) Open the main water tap; 2) Please call Service Center; 3) Check the water pressure of the main water tap; It has to be 2.0 bar at least; 4) Check the overflow pipe and insert it correctly in the tank; 5) Replace the gasket. In case, call Service Center to provide a new spare; 6) Fix up the hose path. In case, call Service Center to replace the hose; 7) Please call Service Center; 8) Please call Service Center; 9) Please call Service Center; 10) Please call Service Center.	2) Clean the valve filter; 5) Provide de spare; 6) Provide de spare; 7) Replace the pressure level switch; 8) Replace the air gap circuit; 9) Replace the filling valve; 10) Replace PCB board.
19	Wash Cycle Indicator fast blinking	Machine run	Wash cycle active and indicator with fast blink, Thermostop activated	1) Cold water in the boiler; 2) Boiler safety thermostat switch tripped; 3) Boiler thermostat switch faulty; 4) Heating element faulty. 3) PCB board faulty.	1) Wait for no more than 8 minutes; 2) Please call Service Center; 3) Please call Service Center; 4) Please call Service Center.	2) Reset the boiler safety thermostat switch; 3) Replace the boiler thermostat switch; 4) Replace the boiler heating element.
20	Wash Cycle Indicator fast blinking	Machine blocked	Tank glasswasher can't be emptied by drain pump	1) Overflow pipe not removed; 2) Tank filter clogged; 3) Drain pump clogged; 4) drain pump faulty; 5) Drain house hose throttled.	1) Remove the overflow pipe; 2) Clean/wash the tank filter; 3) Please call Service Center; 4) Please call Service Center; 5) Please call Service Center	3) Remove and clean the drain pump; 1) Replace the drain pump; 5) Provide the spare.
21	Booster pump out of order	Loss of performance	Glasswasher can't rinse	1) Booster pump clogged; 2) Pump capacitor faulty; 3) Booster pump faulty; 4) PCB board faulty.	Please call Service Center	1) Remove and clean the Booster pump; 2) Replace the pump capacitor; 3) Replace Booster pump; 4) Replace PCB board.
22	Tank heating element is not heating	Loss of performance	Tank doesn't reach the set temperature	1) Tank thermostat faulty; 2) Tank heating element faulty or burnt out; 3) Boiler thermostat faulty.	Please call Service Center	1) Replace the tank thermostat; 2) Replace the tank heating element; Replace the boiler thermostat switch.
23	Boiler heating element is not heating	Loss of performance	Boiler doesn't reach the set temperature	1) Boiler thermostat faulty; 2) Boiler safety thermostat tripped; 3) Boiler safety thermostat faulty; 4) Boiler heating element faulty.	Please call Service Center	1) Replace the boiler work thermostat; 2) Reset the boiler safety thermostat; 3) Replace the safety thermostat; 4) Replace the boiler heating element.

---

## 6 SERVICE THE APPLIANCE

---

### 6.1 LIST OF NEEDED TOOLS

List of needed tools Please, refer to the Electrolux Professional Universal Spare Parts Catalogue.

#### 6.1.1 ORDINARY TOOLS

The following tools take part of the Kit of assorted tools [usp #0S1288] contained in the Tool trolley case [usp #0S1980]:

- Phillips and Flat screwdriver.
- Ratchet wrench M7 or Socket wrenches M7.
- Ratchet wrench M8 or Socket wrenches M8.
- Ratchet wrench M13 or Socket wrenches M13.
- Ratchet wrench M10 or Socket wrenches M10.

#### 6.1.2 SPECIAL TOOLS

In addition to the normal instrumentation, to do the maintenance of this unit the following tools are recommended:

- Digital multimeter [usp #0S1282].
- Current clamp [usp #0S1456].
- Digital thermometer [usp #0S0838] + water immersion-penetration probe [usp #0S1158].
- Water pressure gauge [usp #0S0478].
- Water analysis case [usp #0S0483].
- Step ladder.
- Drill screwdriver.

### 6.2 REPLACING EQUIPMENT COMPONENTS

This chapter introduces the operations to perform when dismantling every single component graphically highlighted.

---

## 6.2.1 COMPONENTS LAYOUT

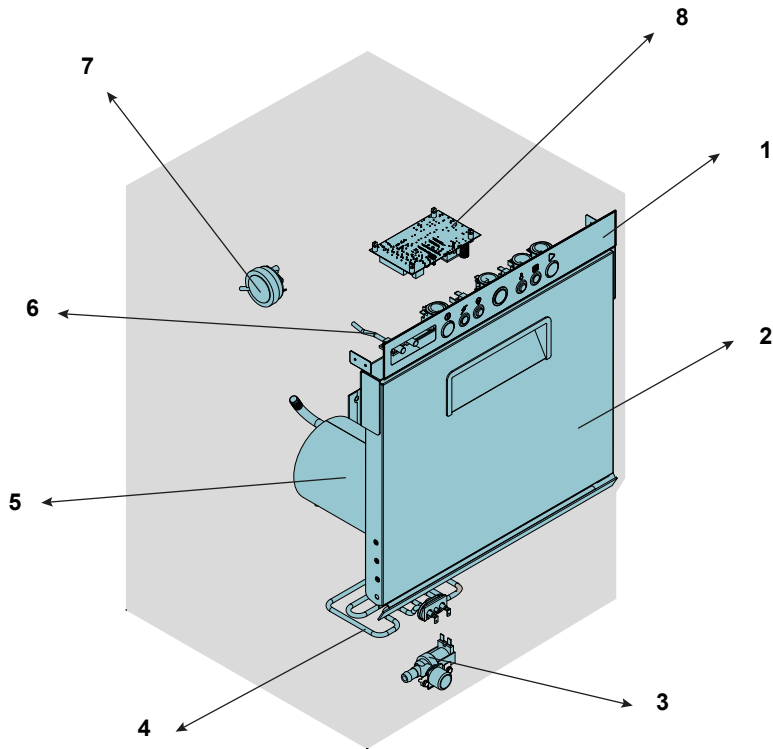

1. Control Panel
2. Door With Hinges
3. Filling Valve
4. Tank Heating Element
5. Boiler Heating Element
6. Door Switch
7. Pressure Switch
8. Pcb Board

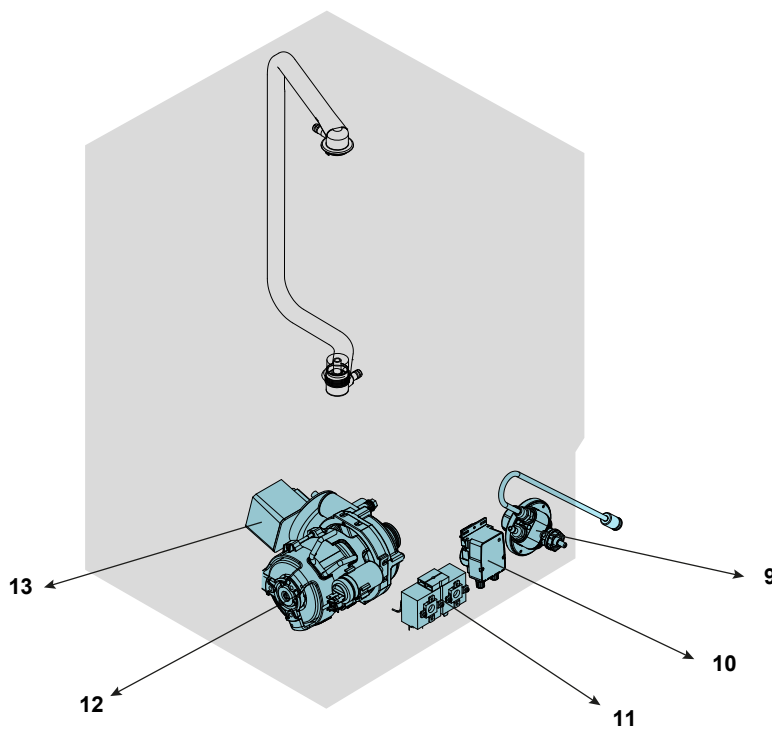

9. Thermostats
10. Detergent dispenser
11. Rinse aid dispenser
12. Washing pump
13. Drain pump

**NOTE**

To access the components, remove the panels as shown in the steps on

## 6.2.2 PANELS

Phases for the replacement of the panels.



**DANGER!** Before any operation on the machine read Chapter 1 "Safety Precautions." To reinstall a part, follow the instructions in reverse order to those described below.

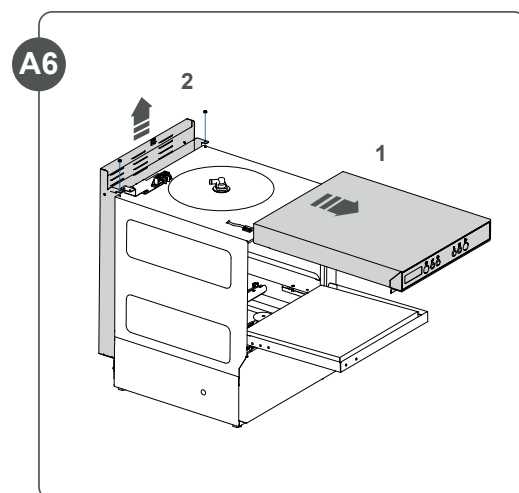
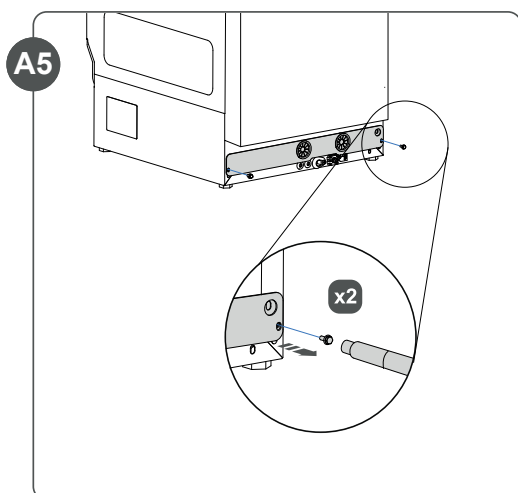
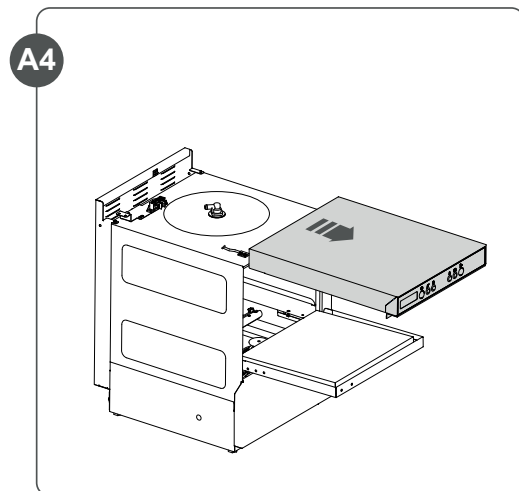
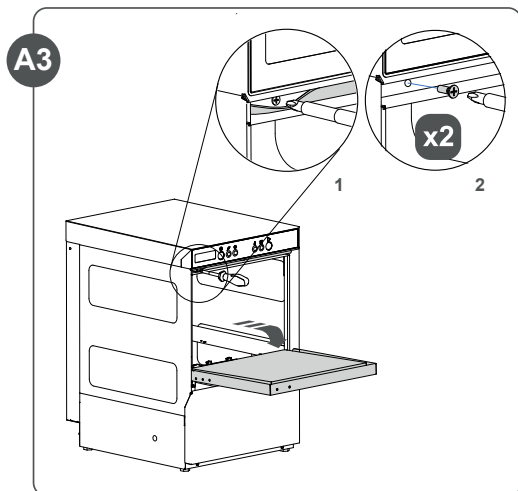
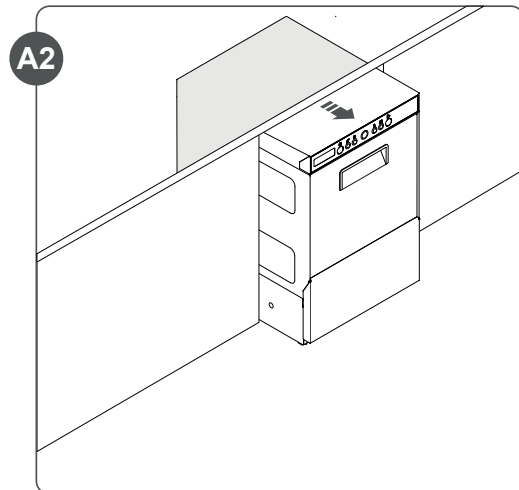
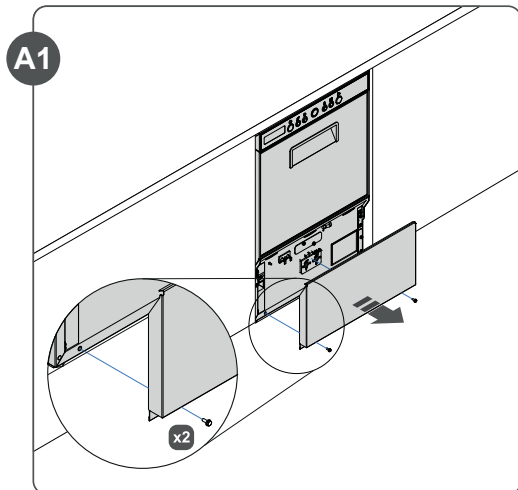

## 6.2.3 DOOR WITH HINGES

1. Open the door
2. Remove the screws (4 pcs) from the basket guides
3. Pull the door by slipping it

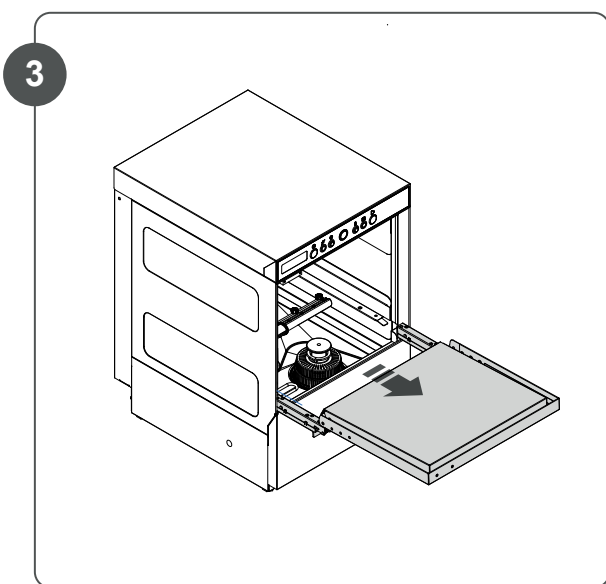
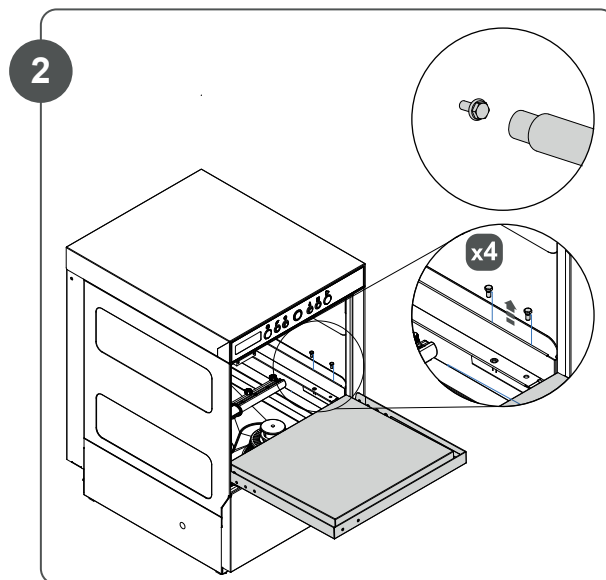
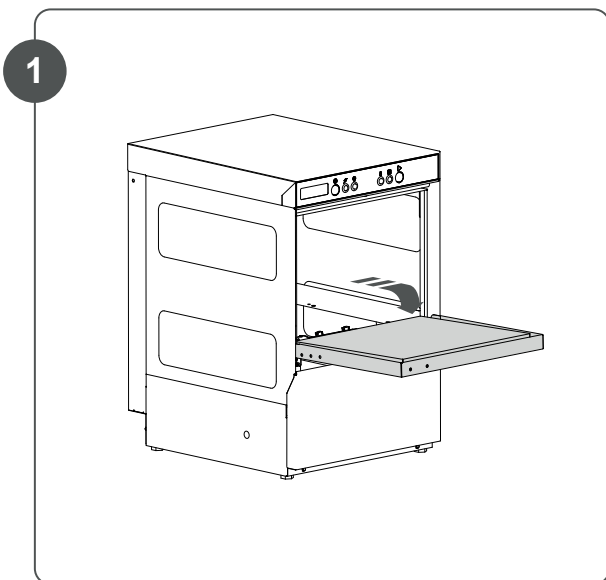

## 6.2.4 CONTROL PANEL

**A3** Remove the screws (2 pcs) under the joint

**A4** Pull the upper panel by slipping it

1. Reverse the upper panel and put it over the door

2. Remove the interruptors/components

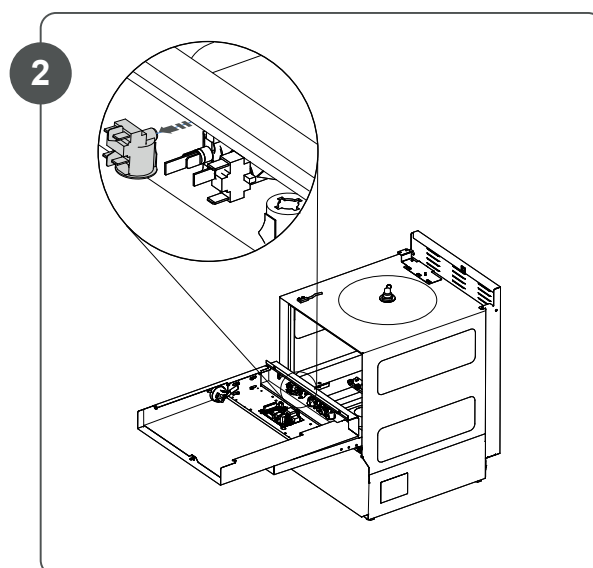
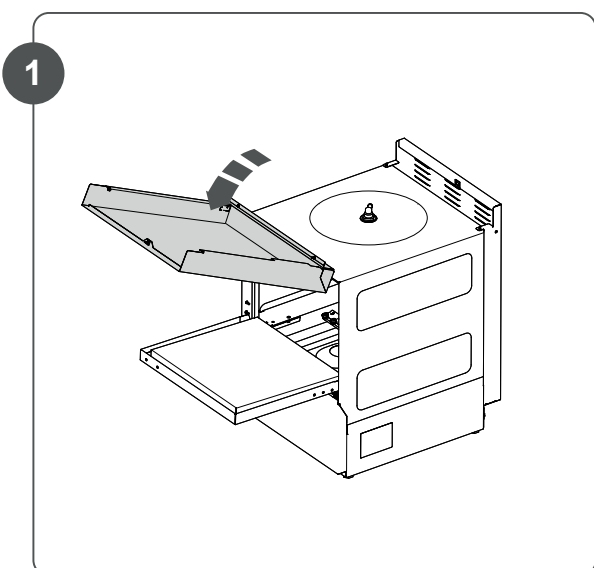
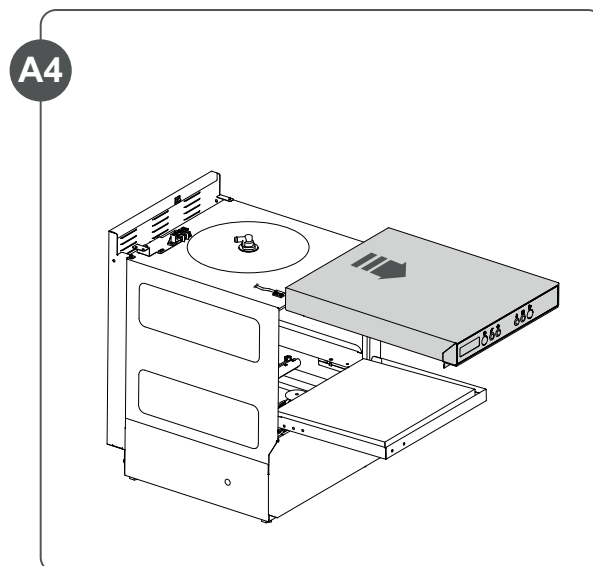
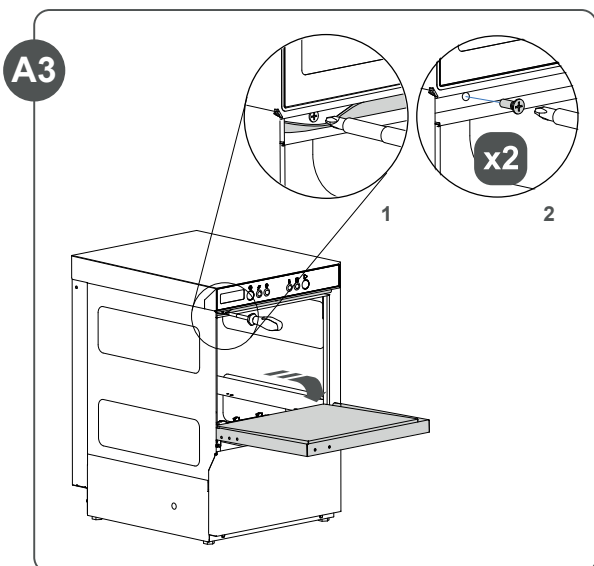

## 6.2.5 DOOR SWITCH

**A3** Remove the screws (2 pcs) under the joint

**A4** Pull the upper panel by slipping it

1. Reverse the upper panel and put it over the door

2. Remove the nuts (2 pcs) over the door microswitch, then disconnect the microswitch wiring

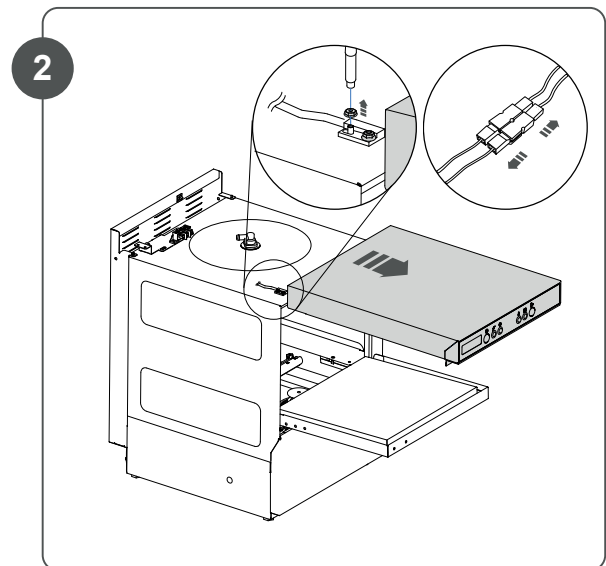
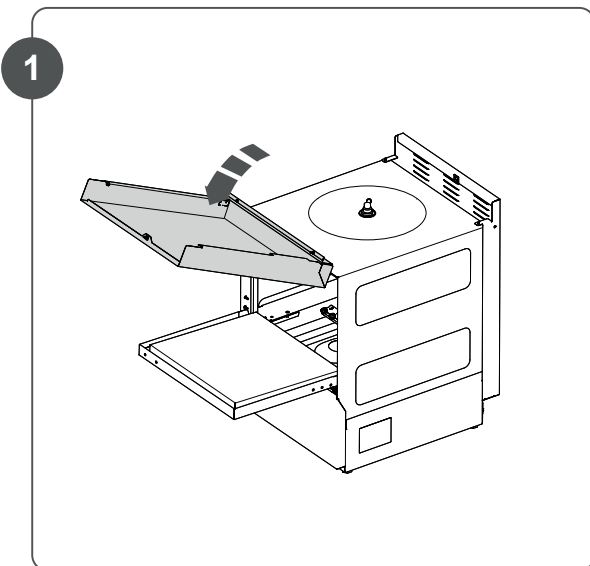
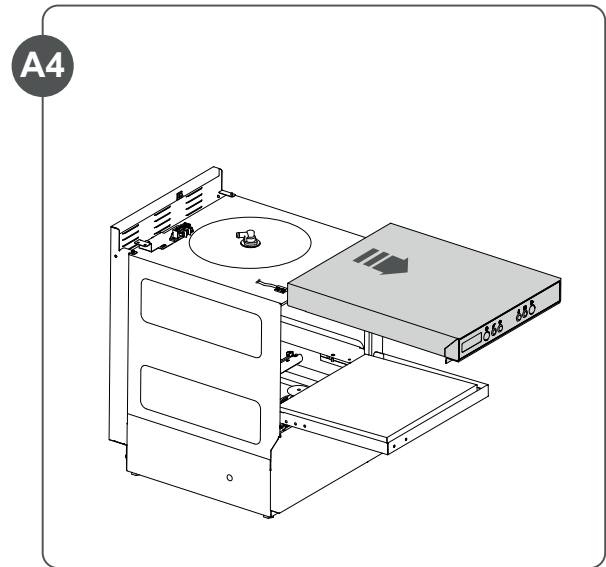
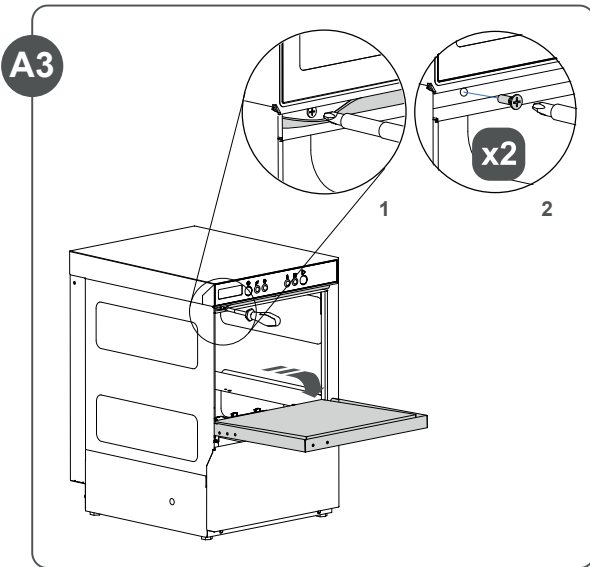



## 6.2.6 PRESSURE SWITCH

**A3** Remove the screws (2 pcs) under the joint

**A4** Pull the upper panel by slipping it

1. Reverse the upper panel and put it over the door

2. Remove the pressure switch pipe, remove the screw that fixes the pressure switch to the support

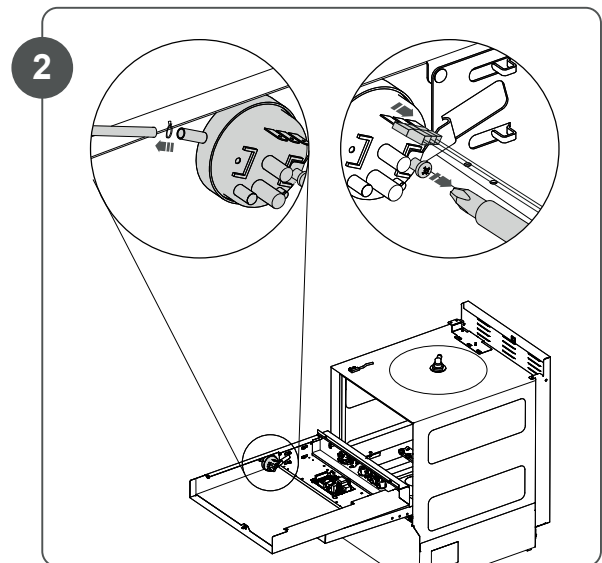
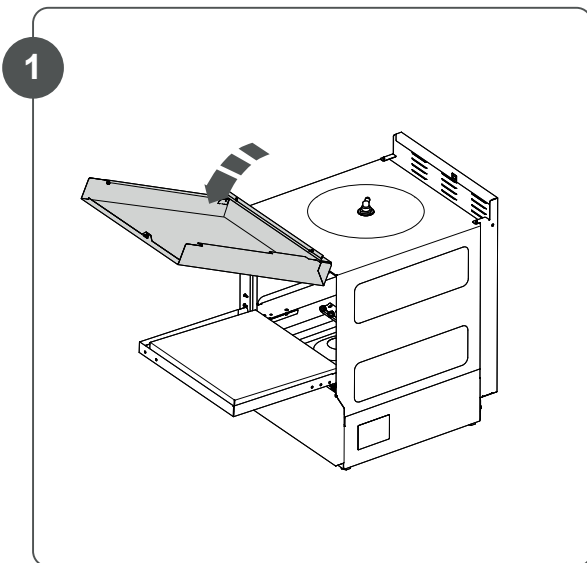
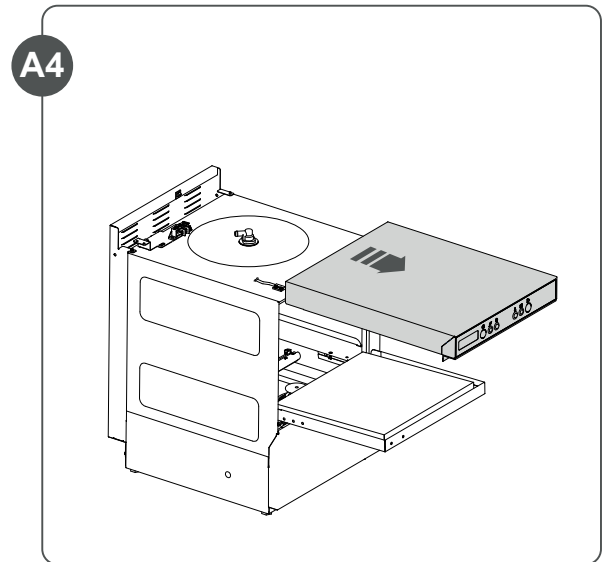
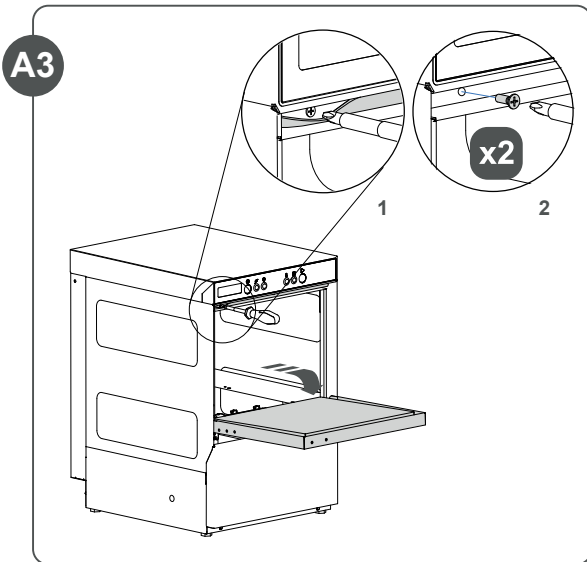

## 6.2.7 PCB

**A3** Remove the screws (2 pcs) under the joint

**A4** Pull the upper panel by slipping it

1. Reverse the upper panel and put it over the door
2. Remove the screws (4 pcs) to divide the PCB from the support

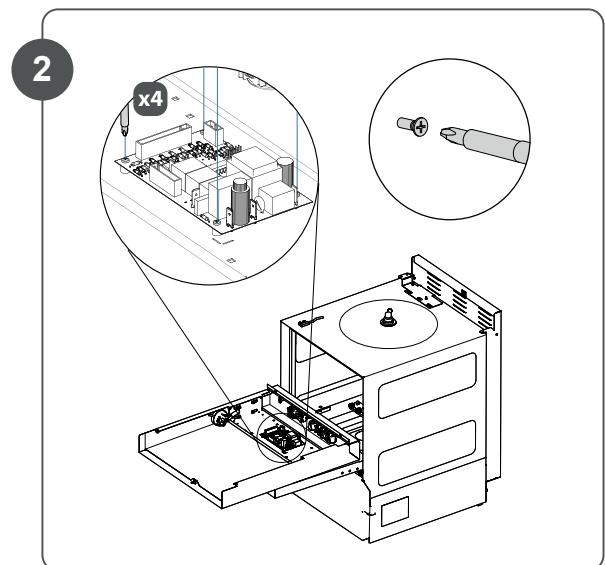
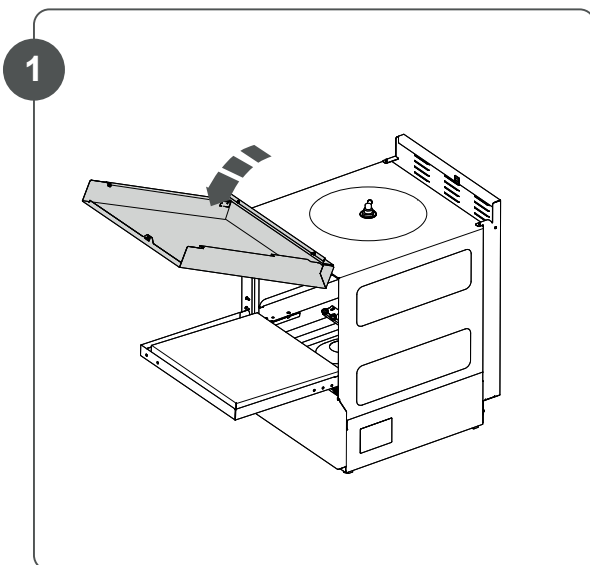
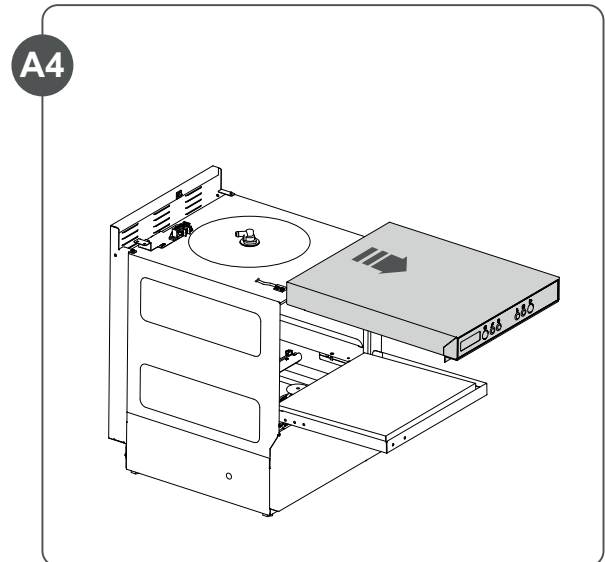
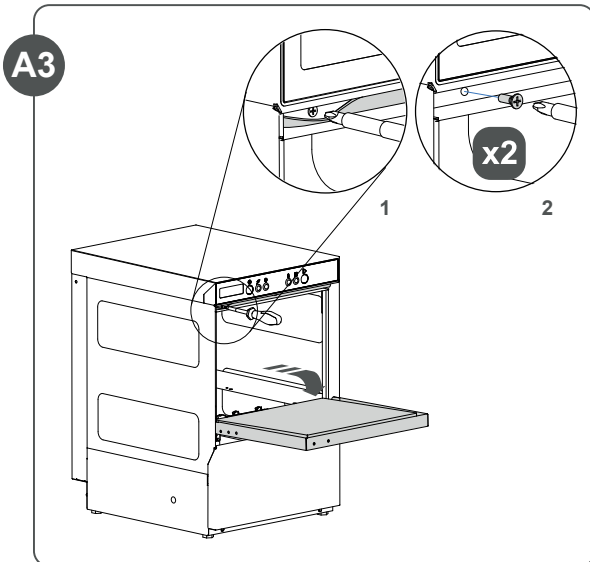

## 6.2.8 TANK HEATING ELEMENT

**A1** Remove the screws (2 pcs) of the under door panel

1. Remove the nut from the tank heating element, then disconnect the tank heating element wiring
2. Gently bend the faston (2 pcs) of the tank heating element
3. Remove the tank heating element

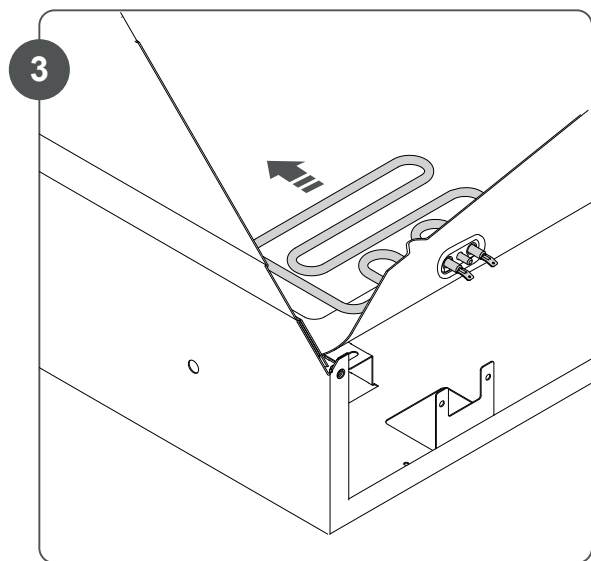
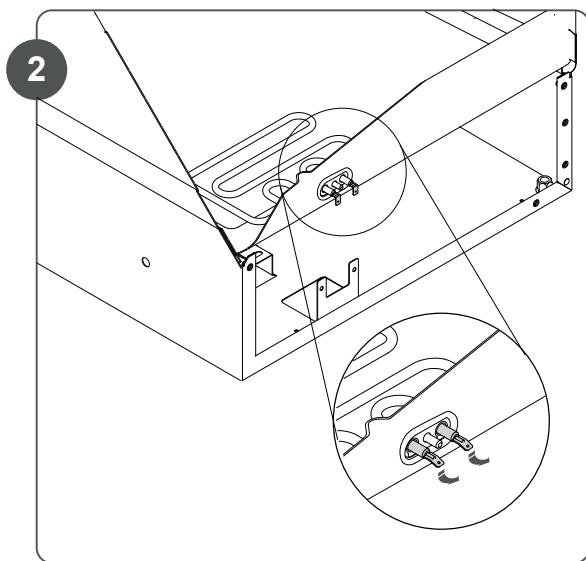
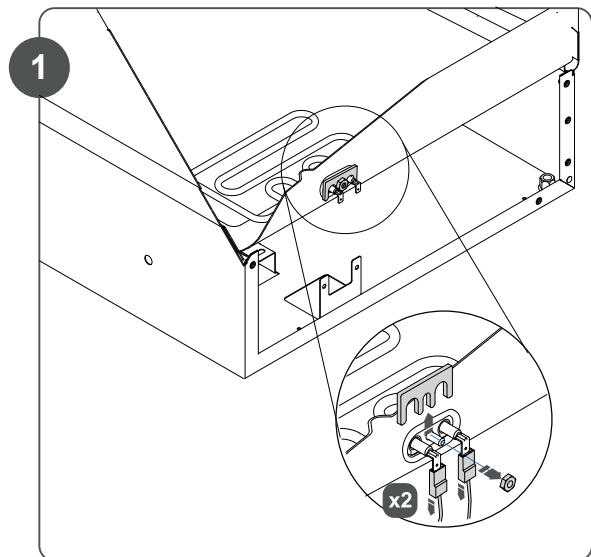
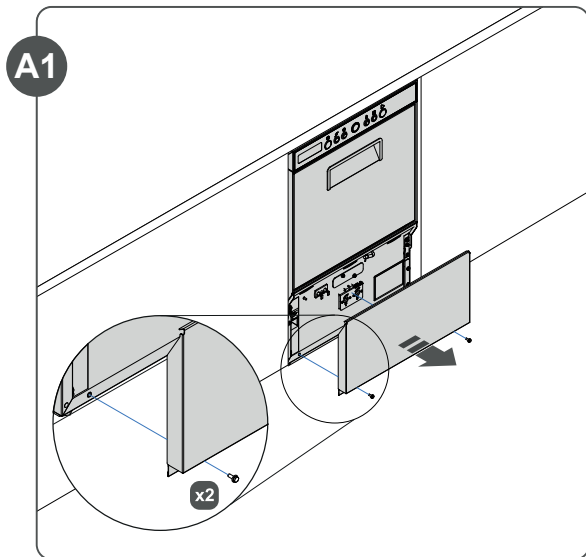

## 6.2.9 INLET WATER FILLING VALVE

**A1** Remove the screws (2 pcs) of the under door panel

1. Close the water inlet faucet

2. Disconnect the water inlet hose, valve exit hose, wiring connections and remove the water inlet valve

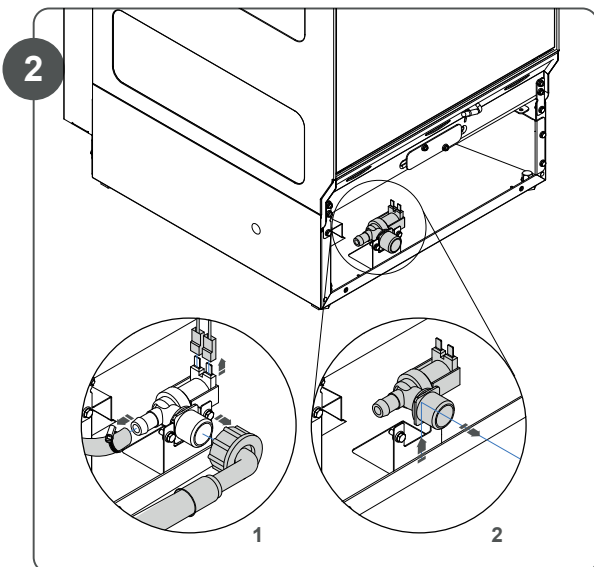
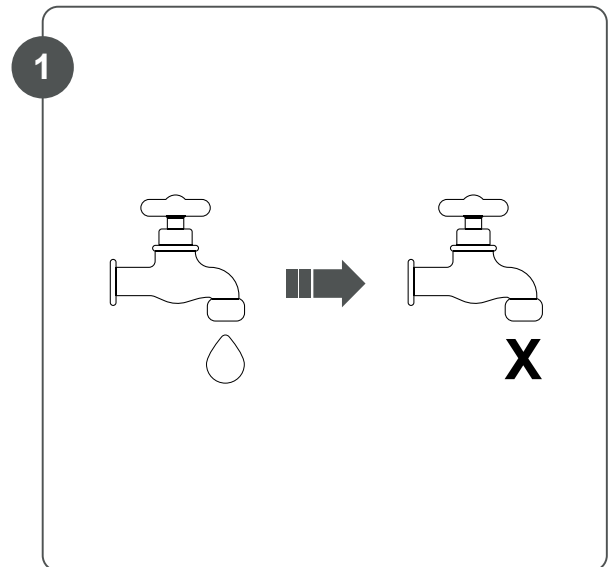
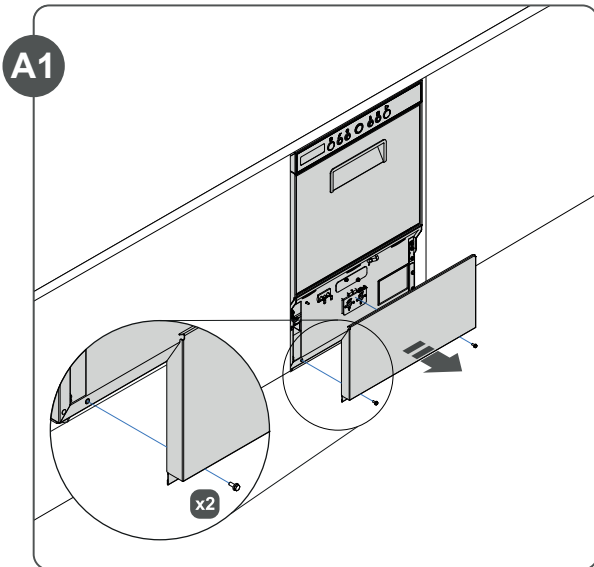

## 6.2.10 BOILER HEATING ELEMENT

- A1** Remove the screws (2 pcs) of the under door panel  
**1.** Remove the screws (2 pcs) of the thermostat support  
**2.** Disconnect the boiler hose. The water is hot, pay attention!  
**3.** When the boiler is empty, remove the nuts (3 pcs)  
**4.** Remove the boiler heating element, and replace the o-ring

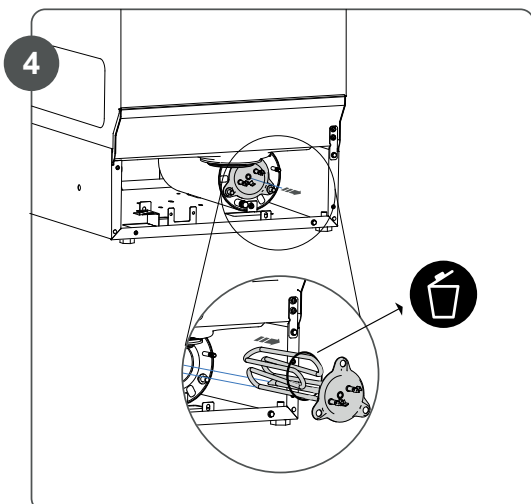
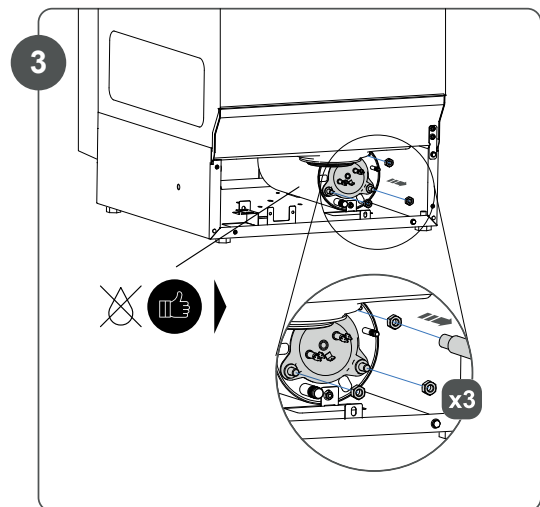
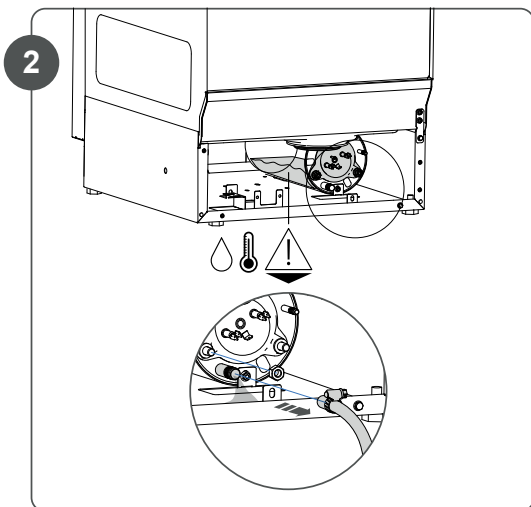
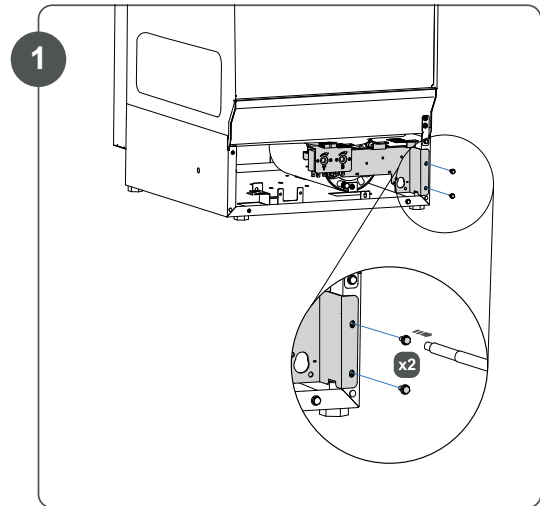
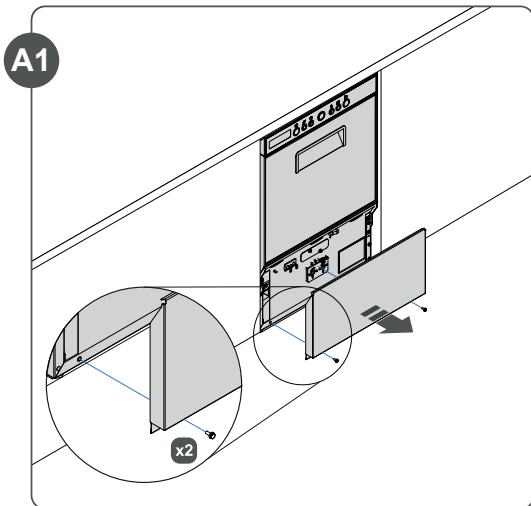

## 6.2.11 WASH PUMP

**A1** Remove the screws (2 pcs) of the under door panel

**1.** Remove the inlet water valve group (don't disconnect the hoses)

**2.** Remove the screws (2 pcs) of the thermostats support

**3.** Remove the clamps (2 pcs) of pump aspiration-supply hoses, then disconnect the hoses

**4.** Lay the dishwasher on its left side, then remove the screws (2 pcs) to divide the pump from the support

**5.** Disconnect the pump wirings

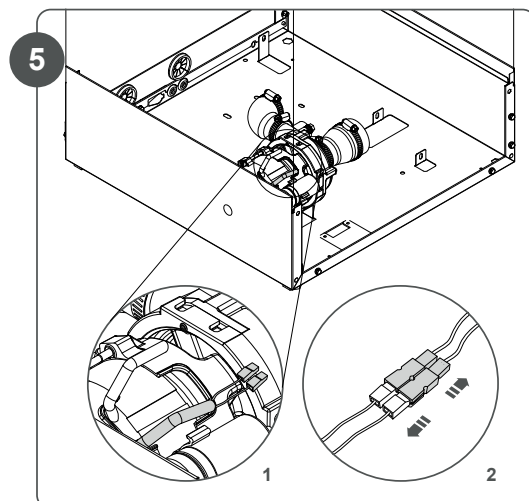
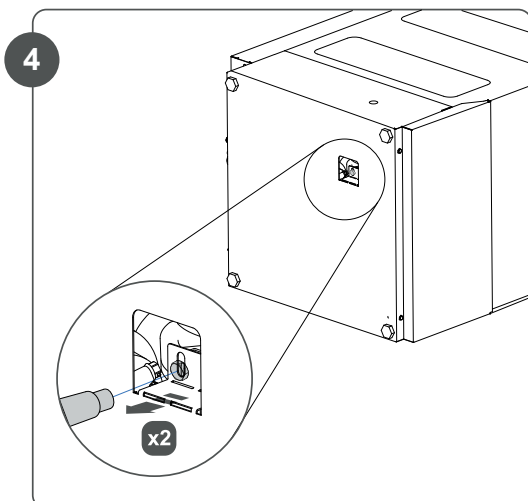
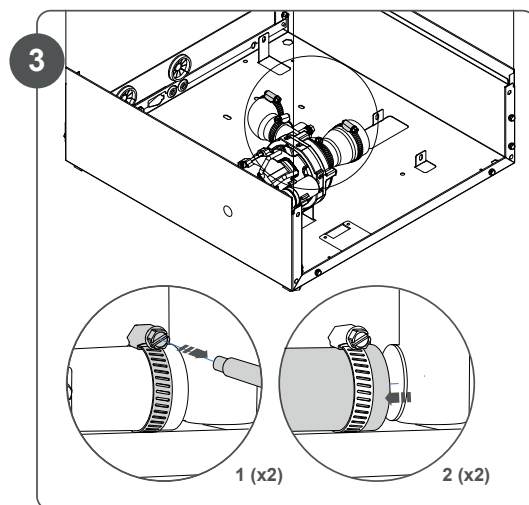
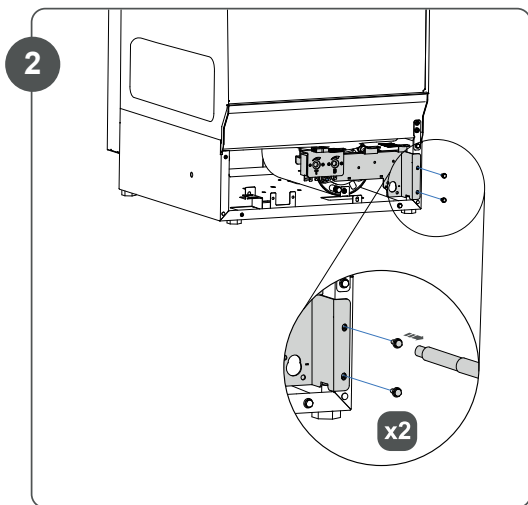
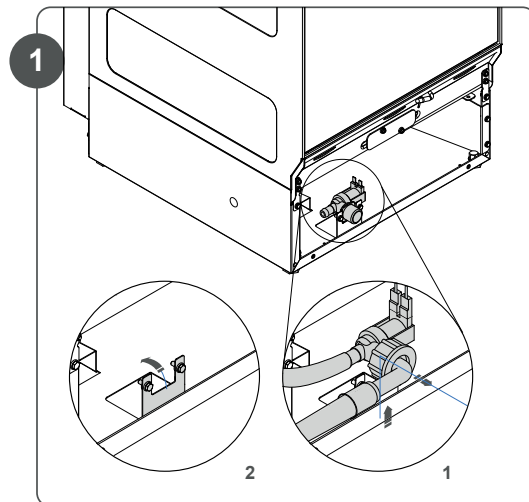
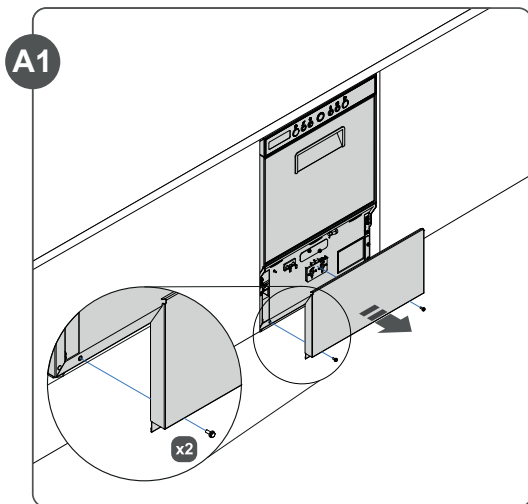

## 6.2.12 DRAIN PUMP

**A1** Remove the screws (2 pcs) of the under door panel

**A2** Take out the dishwasher

**A3** Remove the screws (2 pcs) under the joint

**A4** Pull the upper panel by slipping it

**A5** Remove the screws (2 pcs) of the lower back panel

**A6** Remove the back panel

**1.** Remove the screws (2 pcs) of the thermostats support

**2.** Remove the clamps (2 pcs) of drain pump, then disconnect the hoses

**3.** Remove the screw and bend the support towards the lower compartment

**4.** Remove the drain pump and hoses

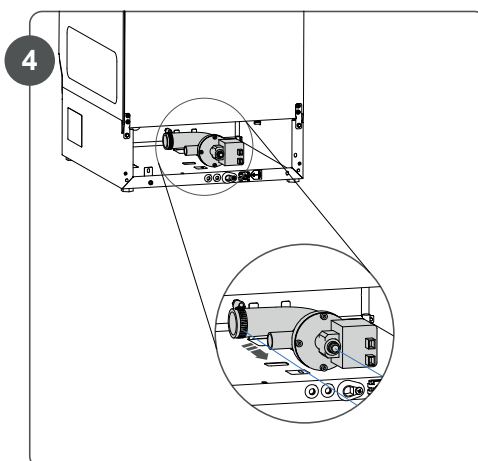
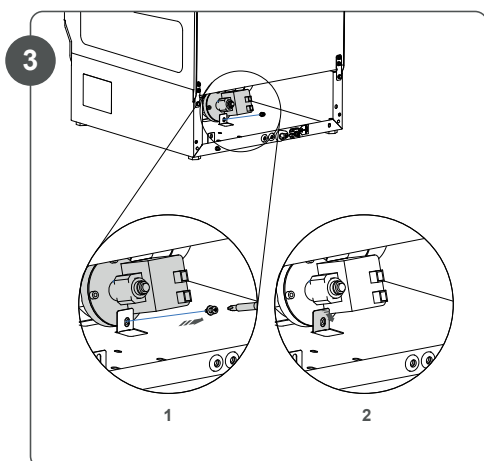
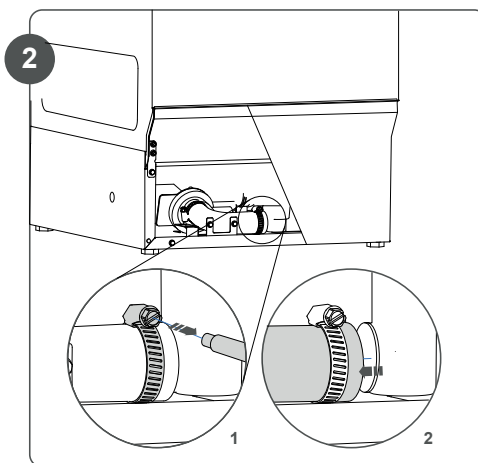
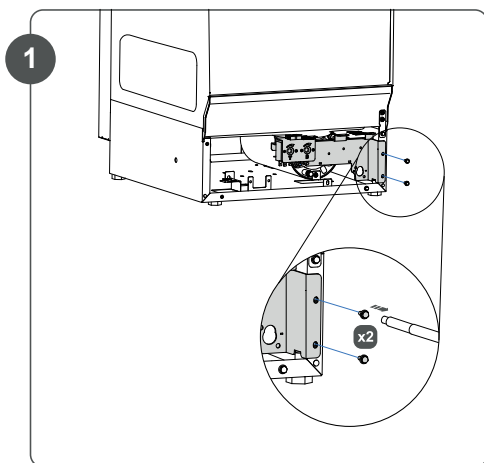
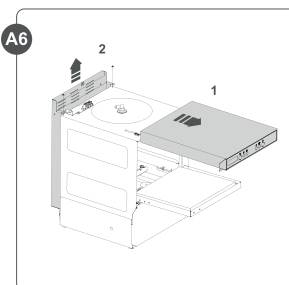
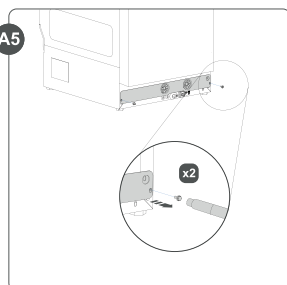
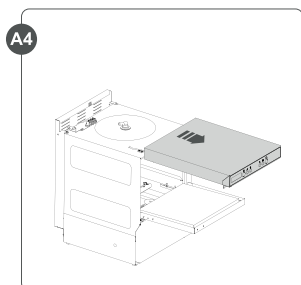
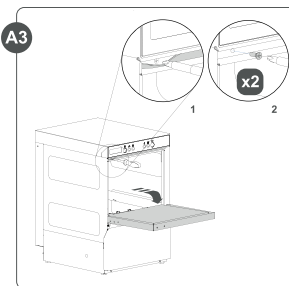
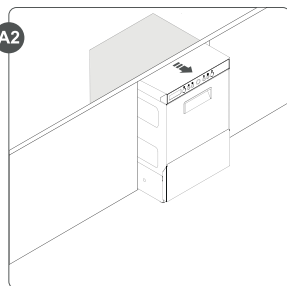
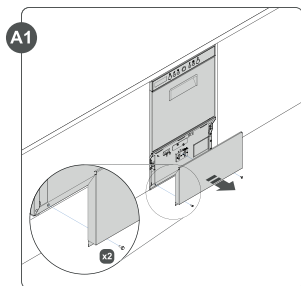

## 6.2.13 RINSE AID PUMP

- A1** Remove the screws (2 pcs) of the under door panel
1. Unscrew the fixing nut
  2. Remove the screws (2 pcs) of the thermostats support
  3. Disconnect the rinse aid pump's pipes

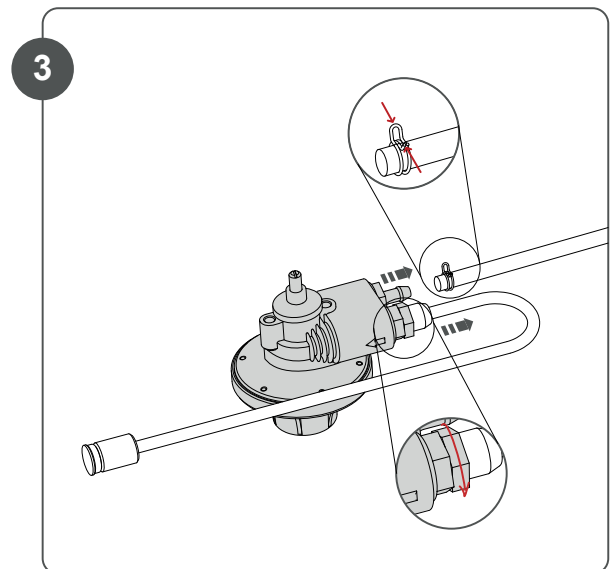
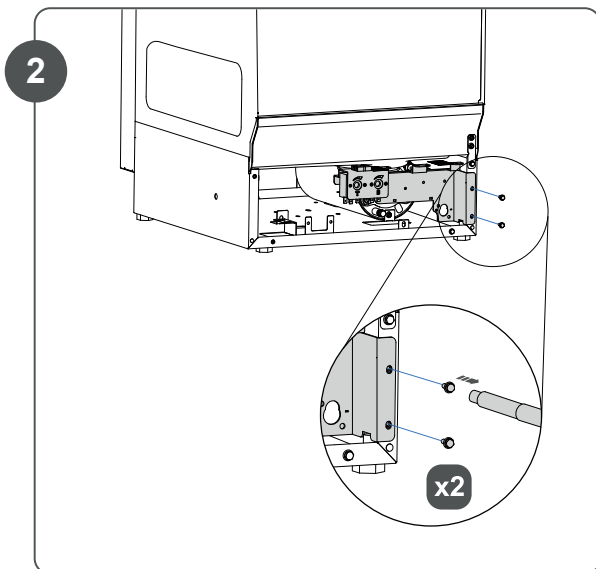
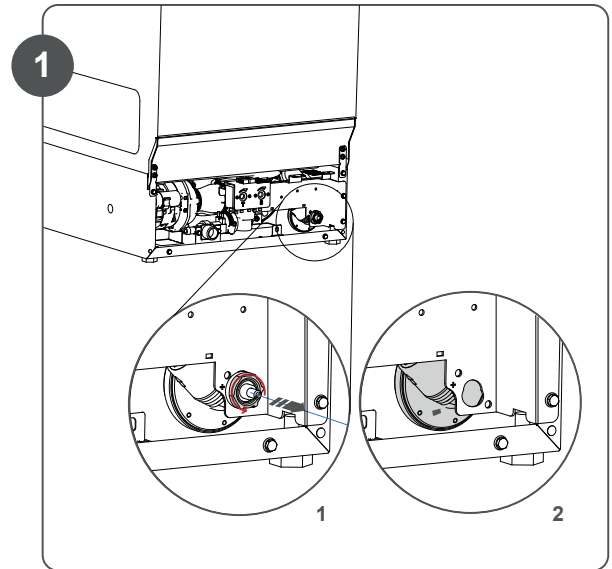
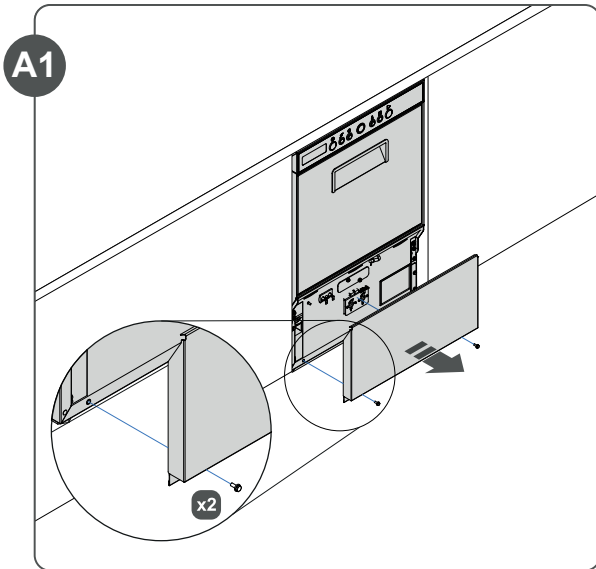



## 6.2.14 DETERGENT PUMP

- A1 Remove the screws (2 pcs) of the under door panel
- 1. Remove the screws (2 pcs) of the thermostats support
- 2. Remove the detergent pump
- 3. Disconnect the detergent's pipes and wiring

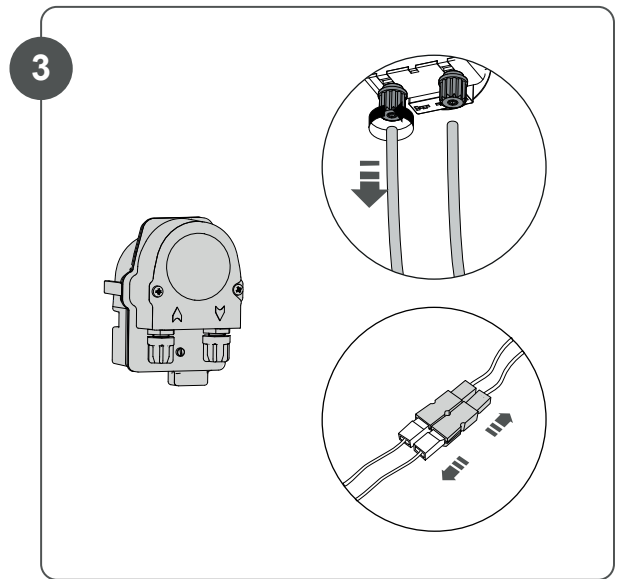
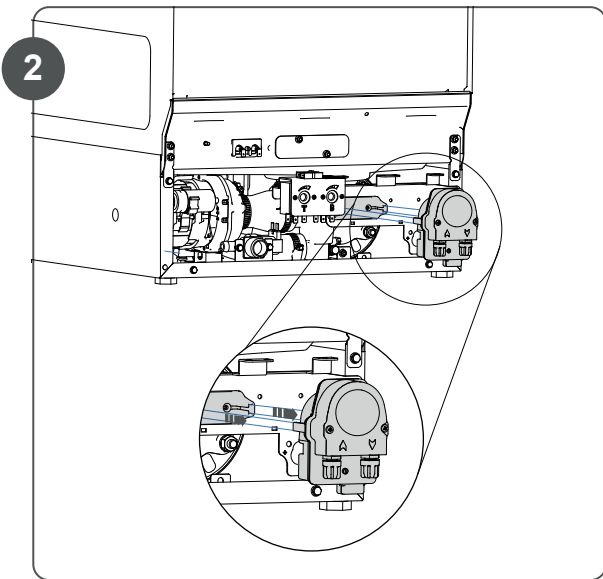
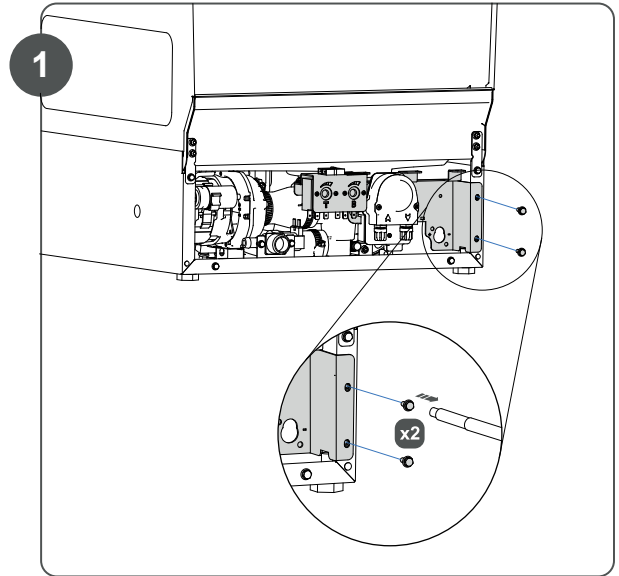
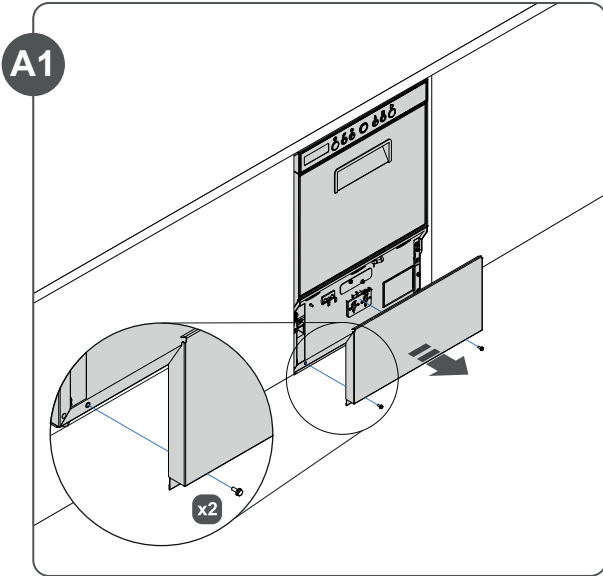

## 6.2.15 PERISTALTIC HOSE OF DETERGENT PUMP

1. Remove the screws (2 pcs) and the cover
2. Remove the inner pipe starting from the left side and turn clockwise the roller holder
3. Turn clockwise the roller holder
4. Remove the roller holder
5. Position the new inner pipe into the seat, starting from the left side
6. Turn clockwise the roller holder
7. Position correctly the inner pipe and turn clockwise the roller holder taking care not to damage the pipe
8. Fix the right side of the inner pipe, close the cover and add screws

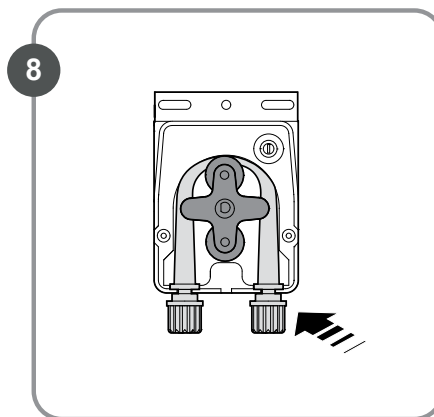
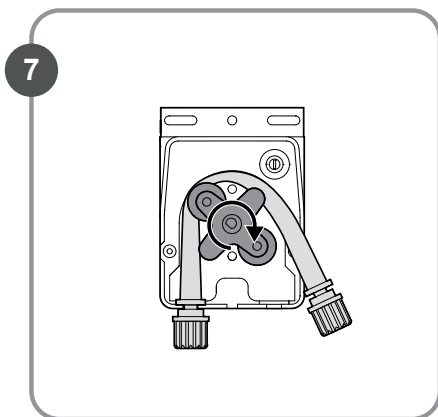
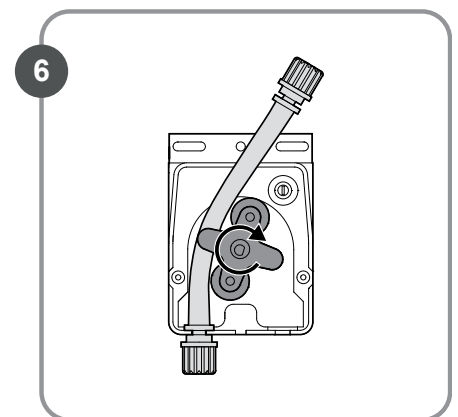
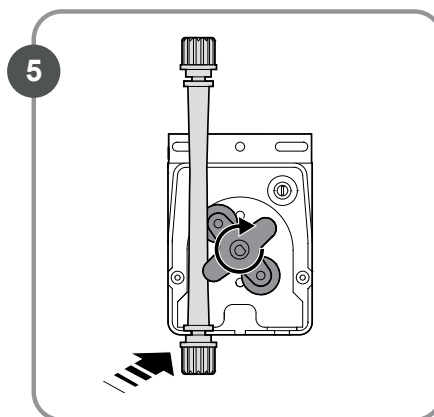
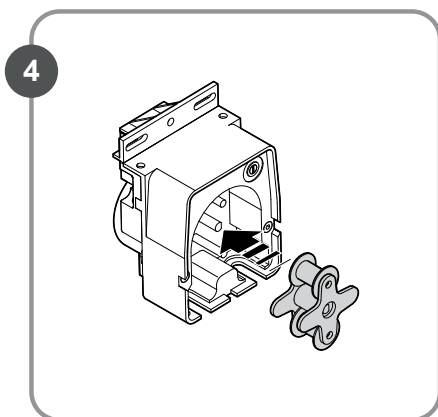
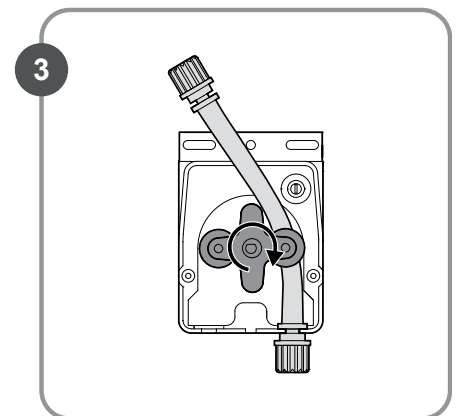
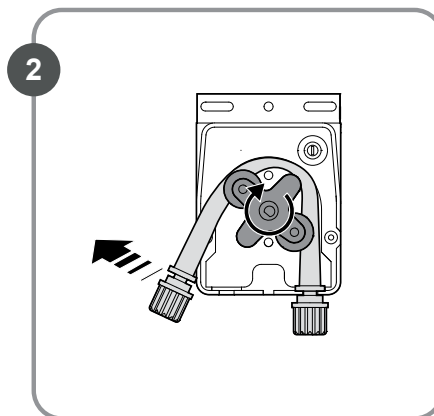
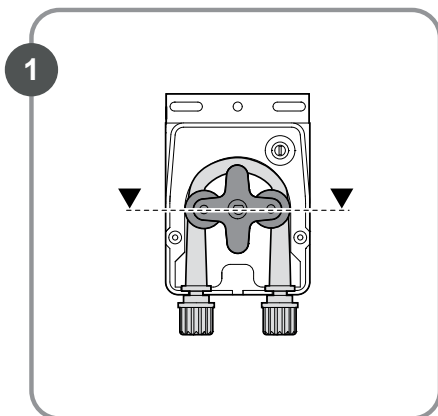

## 6.2.16 THERMOSTATS

- A1** Remove the screws (2 pcs) of the under door panel  
**1.** Remove the screws (2 pcs) of the thermostats support  
**2.** Remove the screws (4 pcs) to take out the thermostats and disconnect the wirings  
**3.** Remove the nuts (2 pcs) of the protection plate. Take out the tank-boiler probes

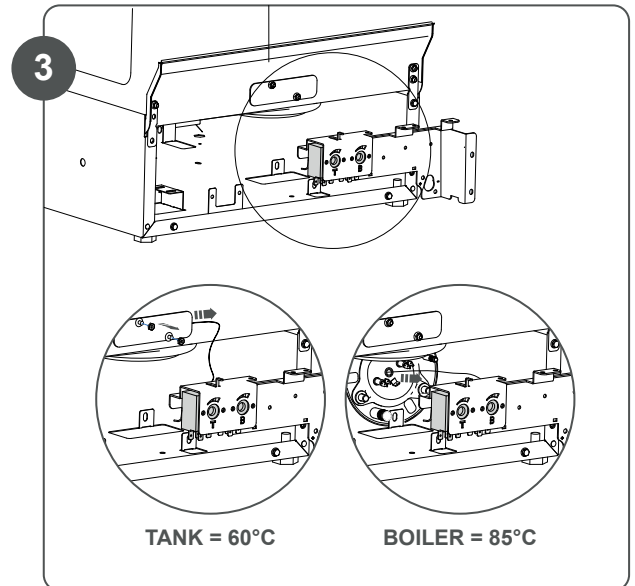
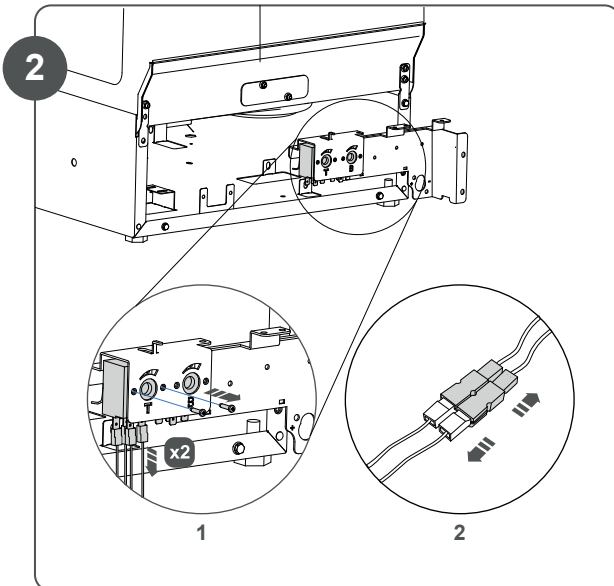
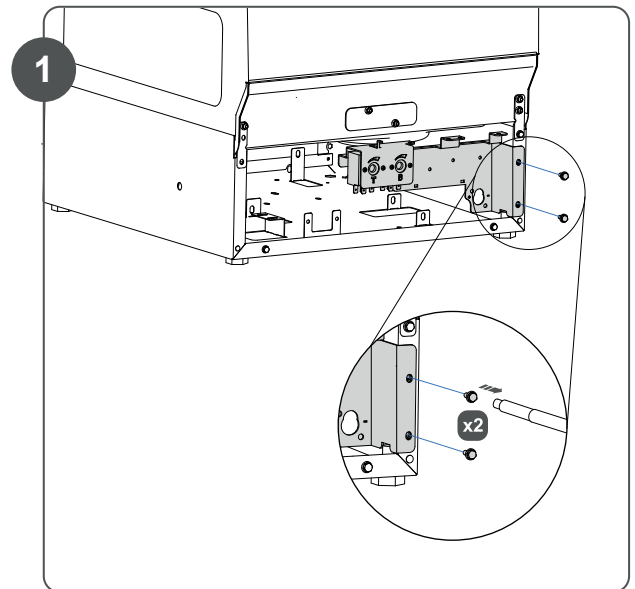
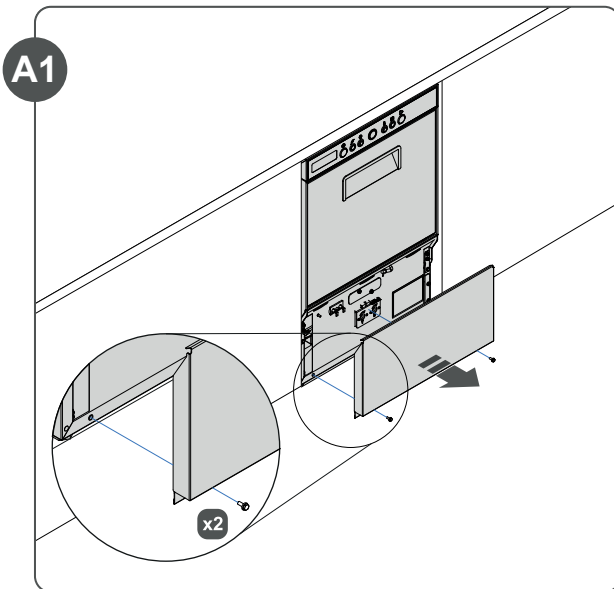

## 6.2.17 THERMOSTOP

**A1** Remove the screws (2 pcs) of the under door panel

**1.** Remove the screws (2 pcs) of the thermostats support

**2.** Move the connector on the terminal at the state you want to achieve (the thermostop is always disabled "OFF").

When the thermostop is activated "ON" the washing cycle can be automatically prolonged up to the boiler temperature has been reached

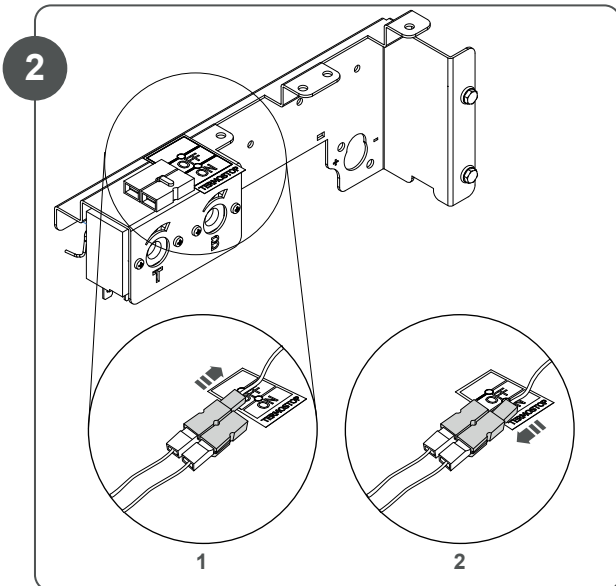
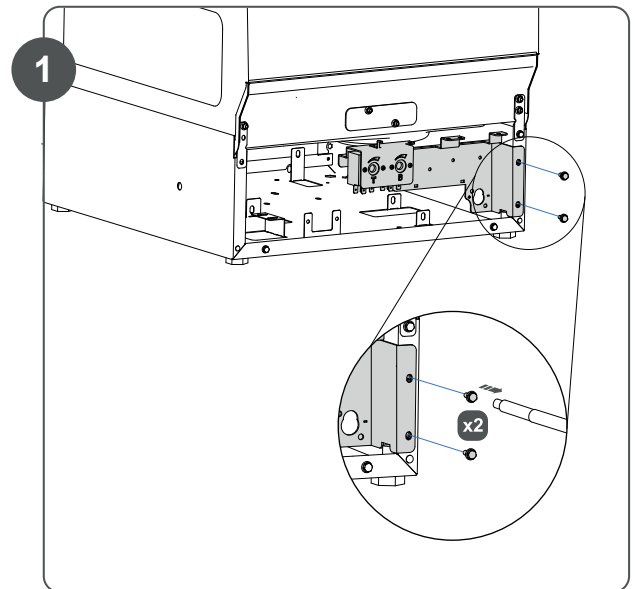
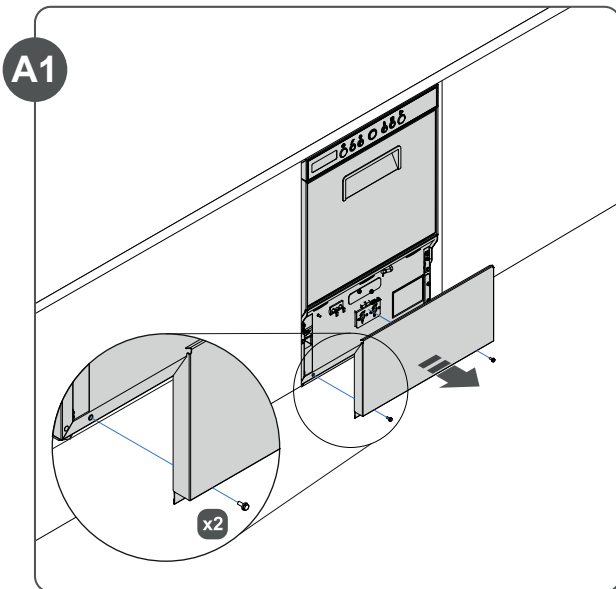

## 7 RELATED DOCUMENTS

### 7.1 ELECTRICAL WIRING DIAGRAM

Please refer to Electrical Wiring Diagram available on web site <https://www.electroluxprofessional.com> or <https://webgate.electroluxprofessional.com>

### 7.2 HYDRAULIC CIRCUITS

Pressure boiler without drain pump

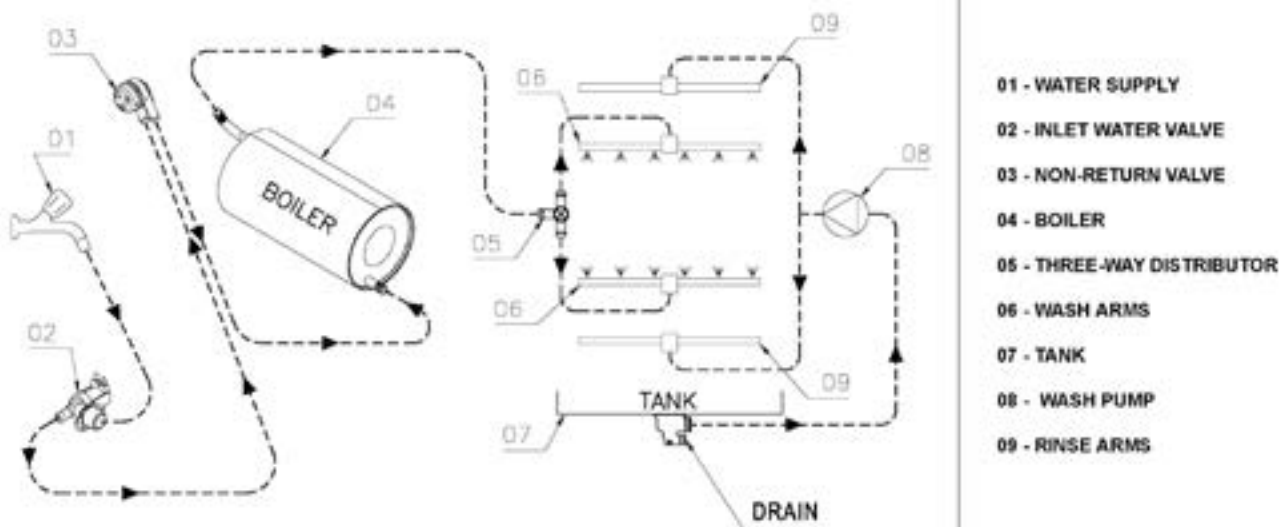

Pressure boiler with drain pump

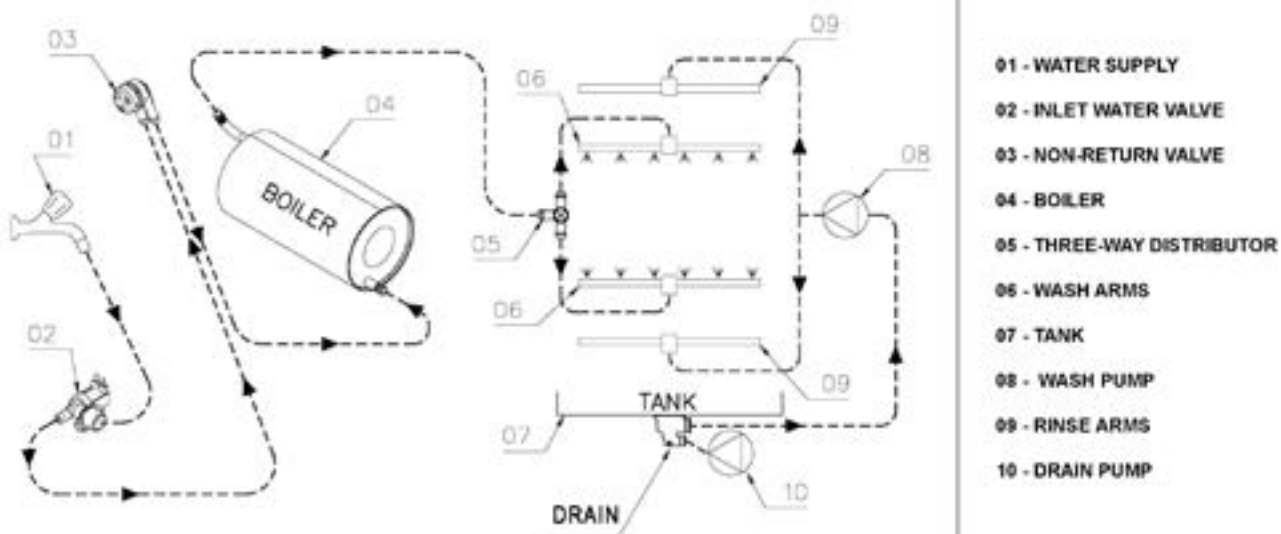

Electrolux Professional SpA  
Viale Treviso, 15  
33170 Pordenone, ITALY  
Fax (+39) 0434 380 201

<https://www.electroluxprofessional.com>  
<https://webgate.electroluxprofessional.com>