



Electrolux

Planetary Mixers Planetary Mixer, 30 Lt. - Electronic with Hub - UK Plug

ITEM # _____

MODEL # _____

NAME # _____

SIS # _____

AIA # _____



Electrolux



Planetary Mixers

Planetary Mixer, 30 Lt. - Electronic with Hub - UK Plug

601894 (XBMF30ASG)

30 Lt planetary mixer with mechanical speed variation. Equipped with spiral hook, beater, whisk and H type accessory hub. UK plug.

Short Form Specification

Item No.

Floor model, suitable for all kneading, blending and whipping operations. Body in non-corrosive material with 18/8 (AISI 302) 30 litre capacity stainless steel bowl. Powerful asynchronous motor (750 W) with mechanical speed variator (8 speed levels from 35 to 180 rpm). Water protected planetary system. Pivoting and removable wire safety screen. Water proof (IP55) and flat touch button control panel with 60 min. timer. A safety device will automatically stop the machine when the bowl is lowered. Adjustable feet for stability. Equipped with accessory drive hub type H (accessories are not included).
Supplied with 3 tools: spiral hook, paddle and whisk. UK plug.

Main Features

- Professional beater mixer that provides all the basic mixer functions: kneading of all sort of pastes, mixing of semi-liquid products, emulsions and various sauces.
- Delivered with:
 - Spiral Hook, Paddle, Wire Whisk and Mixing Bowl for 30 Lt.
 - Accessory drive hub (accessories are not included).
- Waterproof touch button control panel with timer setting and display.
- Mechanical speed variator.
- Maximum capacity (flour, with 60% of hydration) 7 kg, suitable for 100-300 meals per service.
- Pivoting and removable wire safety screen for easier and better cleaning.
- Raising and lowering of the bowl controlled by lever with an automatic locking of the bowl when in the raised position.
- Safety device will automatically stop the machine when the bowl is lowered.

Construction

- Body in non-corrosive material.
- Height adjustable feet.
- Sturdy construction with mechanically welded strong metal frame.
- 302 AISI Stainless steel bowl - 30 lt. capacity.
- Asynchronous motor with high start-up torque.
- 8 speeds, from 35 to 180 prm, to be lever operated while the machine is working, according to the tool and the mixture hardness.
- Water protected planetary system (IP55 electrical controls, IP23 overall machine).
- Power: 750 watts.
- Planetary movement based on self lubricating gears, eliminating any risk of leaks.

APPROVAL: _____



Included Accessories

- 1 of Additional Bowl 30 Lt PNC 653160
- 1 of Additional Spiral Hook 30 Lt PNC 653161
- 1 of Additional Paddle 30 Lt PNC 653165
- 1 of Additional Whisk 30 Lt PNC 653166

Optional Accessories

- Vegetable cutter for H hub with ejector PNC 653015
- Sharpening grindstone for H accessory hub PNC 653062
- 20 Lt reduction kit (bowl, spiral hook, paddle, whisk) for 30 Lt planetary mixers PNC 653159
- Additional Bowl 30 Lt PNC 653160
- Additional Spiral Hook 30 Lt PNC 653161
- Additional Paddle 30 Lt PNC 653165
- Additional Whisk 30 Lt PNC 653166
- Puree strainer for H hub with 3 grids PNC 653187
- Vegetable cutter for H hub, disconnectable PNC 653225
- 10 Lt capacity planetary mixer, attachment type H and 3 tools included PNC 653226
- Reinforced whisk for 30lt planetary mixers PNC 653253
- Stainless steel dish shelf for 20lt and 30lt planetary mixers PNC 653435
- 10 Lt reduction equipment (bowl and 3 tools) and removable spout PNC 653494
- Kit wheels for 20/30/40 litre planetary mixers PNC 653552
- Bowl trolley for 20/30 Lt planetary mixers (cannot be used with wheel kit 653552) PNC 653562
- Full plastic safety screen for 20/30 Lt planetary mixers PNC 653622
- Aluminium external support for 70 mm meat mincer (includes tray and pusher) - H HUB - To be combined with a meat mincer kit PNC 653720
- Aluminium meat mincer kit 70 mm - Enterprise cut, includes blade (3 discs, diam. 4.5 - 6 and 8 mm) PNC 653721
- Stainless steel meat mincer kit 70 mm - Enterprise cut, includes blade (3 discs, diam. 4.5 - 6 and 8 mm) PNC 653722
- Stainless steel meat mincer kit 70 mm - 1/2 Unger cut, includes blade (4 discs, diam. 0, 3 - 4.5 and 8 mm) PNC 653723





Electrolux

Planetary Mixers Planetary Mixer, 30 Lt. - Electronic with Hub - UK Plug

Front

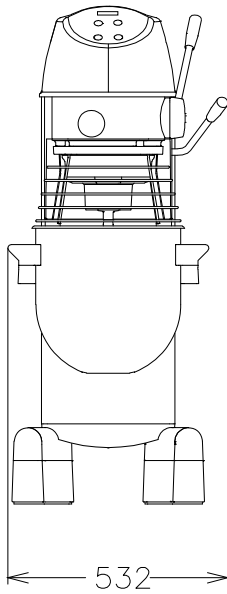

Top

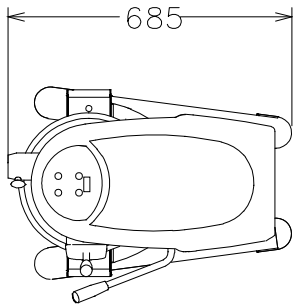

Side

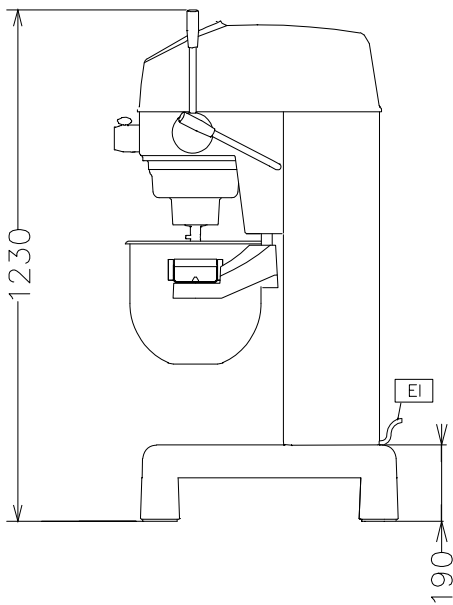

EI = Electrical connection

Electric

Supply voltage:

601894 (XBMF30ASG)

220...240 V/1N ph/50 Hz

Capacity

Performance (up to):

7 - kg/Cycle

Capacity

30 liter

Key Information

External dimensions, Height

1230 mm

External dimensions, Width

532 mm

External dimensions, Depth

685 mm

Shipping weight:

116 kg

Net weight (kg):

110

Cold water paste:

7 kg with Spiral hook

Egg whites:

50 with Whisk



Planetary Mixers
Planetary Mixer, 30 Lt. - Electronic with Hub - UK Plug

The company reserves the right to make modifications to the products without prior notice. All information correct at time of printing.

2014.06.26