



Electrolux

Planetary Mixers Planetary Mixer, 10 Lt. - Electronic with Hub - UK Plug

ITEM # _____

MODEL # _____

NAME # _____

SIS # _____

AIA # _____



Electrolux



Planetary Mixers

Planetary Mixer, 10 Lt. - Electronic with Hub - UK Plug

601999 (XBEF10ASG)

10 Lt planetary mixer, electronic speed variation. Equipped with spiral hook, beater, whisk and H type accessory hub. UK plug

Short Form Specification

Item No.

Suitable for all kneading, blending and whipping operations. Body, feet and 10 litre capacity bowl in stainless steel. One piece alloy head holding the planetary mechanism and the drive. Water proof (IP55) and flat touch button control panel with 60 min. timer. Powerful asynchronous motor (750 W) with electronic speed variation adjusted by a potentiometer (10 speed levels from 26 to 180 rpm). Removable transparent safety screen activates the raising and lowering of the bowl. A safety device will automatically stop the machine when the bowl is lowered. Adjustable feet for stability. Equipped with accessory drive hub type H (accessories are not included).

Supplied with 3 tools: spiral hook, paddle and whisk. UK plug

Main Features

- Professional beater mixer that provides all the basic mixer functions: kneading of all sort of pastes, mixing of semi-liquid products, emulsions and various sauces.
- Delivered with:
 - Spiral Hook, Paddle, Wire Whisk and Mixing Bowl for 10 Lt.
 - Accessory drive hub (accessories are not included).
- Electronic speed variator.
- Removable safety screen - thanks to a "clip" system without screws - activates the raising and lowering of the bowl.
- Maximum capacity (flour, with 60% of hydration) 3.5 kg, suitable for 10-50 meals per service.
- Safety device will automatically stop the machine when the bowl is lowered.

Construction

- Compact design for table top installations.
- Body entirely in stainless steel.
- Sturdy construction with mechanically welded strong metal frame.
- AISI 302 stainless steel bowl - 10 Lt. capacity.
- Asynchronous motor with high start-up torque.
- Planetary movement based on self lubricating gears, eliminating any risk of leaks.
- 10 speeds from 26 to 180 rpm (planetary movement), to adjust to the selected tool and mixture hardness.
- Water protected planetary system (IP55 electrical controls, IP34 overall machine).
- Power: 750 watts.

Included Accessories

- 1 of Additional Paddle 10 Lt PNC 653267
- 1 of Additional Spiral Hook 10 Lt PNC 653268
- 1 of Additional Whisk 10 Lt PNC 653269
- 1 of Additional Bowl 10 Lt PNC 653276

Optional Accessories

- Vegetable cutter for H hub with ejector PNC 653015
- Puree strainer for H hub with 3 grids PNC 653187
- Vegetable cutter for H hub, disconnectable PNC 653225
- Additional Paddle 10 Lt PNC 653267
- Additional Spiral Hook 10 Lt PNC 653268
- Additional Whisk 10 Lt PNC 653269
- Additional Bowl 10 Lt PNC 653276
- Aluminium external support for 70 mm meat mincer (includes tray and pusher) - H HUB - To be combined with a meat mincer kit PNC 653720
- Aluminium meat mincer kit 70 mm - Enterprise cut, includes blade (3 discs, diam. 4.5 - 6 and 8 mm) PNC 653721
- Stainless steel meat mincer kit 70 mm - Enterprise cut, includes blade (3 discs, diam. 4.5 - 6 and 8 mm) PNC 653722

APPROVAL: _____



Electrolux

Planetary Mixers Planetary Mixer, 10 lt. - Electronic with Hub - UK Plug

- Stainless steel meat mincer kit 70 mm - 1/2 PNC 653723 □
Unger cut, includes blade (4 discs, diam. 0, 3 -
4.5 and 8 mm)



Planetary Mixers
Planetary Mixer, 10 lt. - Electronic with Hub - UK Plug

The company reserves the right to make modifications to the products
without prior notice. All information correct at time of printing.

2014.06.24



Electrolux

Planetary Mixers Planetary Mixer, 10 lt. - Electronic with Hub - UK Plug

Front

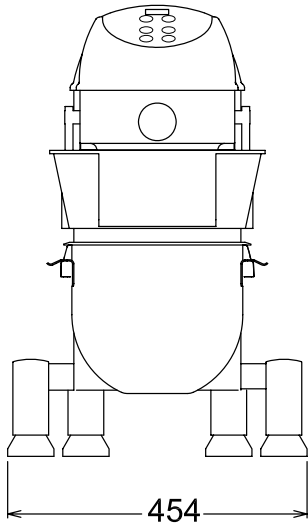

Top

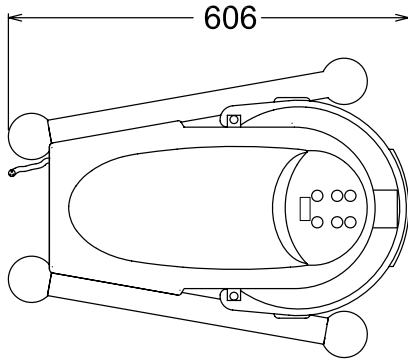

EI = Electrical connection

Side

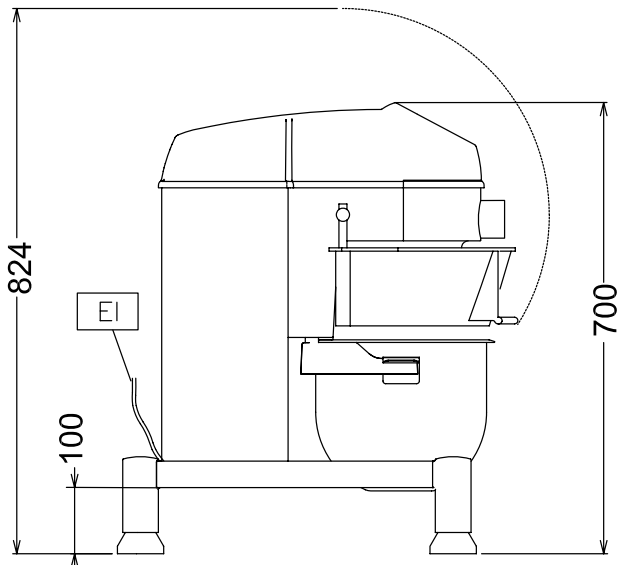

Electric

Supply voltage:

601999 (XBEF10ASG) 220...240 V/1N ph/50/60 Hz

Connected load:

0.75 kW

Capacity

Performance (up to):

3.5 - kg/Cycle

Capacity

10 liter

Key Information

External dimensions, Height 700 mm

External dimensions, Width 454 mm

External dimensions, Depth 606 mm

Shipping weight: 49 kg

Net weight (kg): 38

Cold water paste: 3.5 kg with Spiral hook

Egg whites: 18 with Whisk



**Planetary Mixers
Planetary Mixer, 10 lt. - Electronic with Hub - UK Plug**

The company reserves the right to make modifications to the products without prior notice. All information correct at time of printing.

2014.06.24