

**602168 (TBXPROVT)**

TBX Pro Turboliquidizer motor only (without tools), variable speed, 630-1700 rpm

**Main Features**

- Mixer tube is easily removable without tools and can be dismantled in separate parts: tube, shaft, bearing and rotor.
- Safety device allows the machine to start only when it is in a working position.
- Turbine accelerates the flow of the liquid over the impeller providing a greater throughput and finer grinding.
- Used to mix, blend and emulsify vegetable and soups, fruit and vegetable purées, liquid pastries, sauces and much more directly in cooking pots/containers.
- Suggested for pans containing up to 700 liters of liquid or up to 200 kg of potatoes.
- Includes only the motor base. To have a functioning appliance, tube(s) and tool(s) must be ordered separately (see optional accessories).
- Adapt to all types of cooking containers and rim heights, with 3 tube lengths (348 mm for braising pans, 448 mm or 568 mm) and 4 tools for soup/puree (deep pots/braising pans).
- Wide speed adjustment range (20 steps) allows to adapt to any processing type, starting slow and increasing speed gradually.
- Equipped with crank handle for fast and easy height adjustment.
- All components of tube and head are in stainless steel and dishwasher safe (excluding bearings).
- For mash prepared with potatoes, using specific puree tool (see optional accessories).

**Construction**

- Power: 1500 watts.
- Constructed entirely in stainless steel to offer maximum durability.
- Variable speed: 20-steps from 630 to 1700 rpm.
- Mounted on a mobile stainless steel trolley (4 wheels with brakes). Storage position: fold down motor/arm to save space.
- Trolley with support to store up to two tubes (with assembled tool).
- CE approved (Machine Directive) with EN test report from third party notified body.
- IP65 waterproof control panel, IP23 throughout the entire machine.
- 250mm height adjustment range for the motor body. Different tube lengths allow to adapt to pot depths (see optional accessories).
- All parts in contact with food are conform to 1935/2004/EC.
- Equipped with 8 m power cord without plug.



## Optional Accessories

PNC Code	Description
<b>Mixing tubes &amp; supports</b>	
653822	TBX Pro medium tube with deflector 448 mm
<b>Tubes/heads/grids</b>	
650168	TBX Pro soup grid, hole diam. 8-10 mm
650172	TBX Pro soup head (without tube)
650173	TBX Pro puree head for Braising Pan (without tube)
650175	TBX Pro medium tube 448 mm
650176	TBX Pro long tube 568 mm
650177	TBX Pro puree head (without tube)
653507	TBX Pro fish soup grid, hole diam. 19 mm
653521	TBX Pro soup head for Braising Pan (without tube)
653821	TBX Pro short tube with deflector, 348 mm (recommended for Braising Pans)



# Technical specifications

## Electric

Supply voltage:	380-480 V/3 ph/50-60 Hz
Electrical power max.:	1.5 kW
Plug type:	Cable without plug
<b>Key Information:</b>	
External dimensions, Width:	628 mm
External dimensions, Depth:	1556 mm
External dimensions, Height:	1122 mm
Net weight:	80 kg
Shipping weight (gross):	94 kg
Height adjustment:	1122/1372 mm
Waterproof index:	IP23
Number of speeds:	
Rotation speed:	[tb_PDB_TSDynPrep.fSpinDryerRP M VALUE NOT FOUND] rpm

## Side

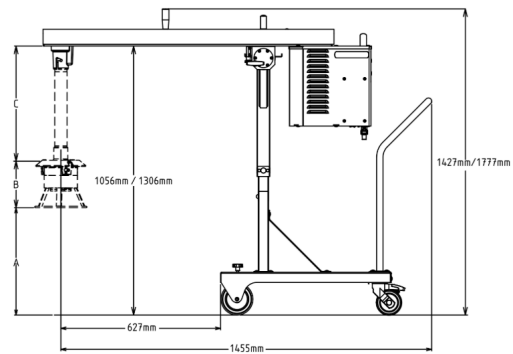

## Top

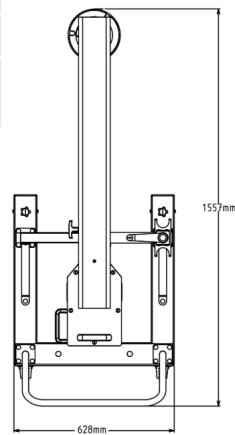

## Other

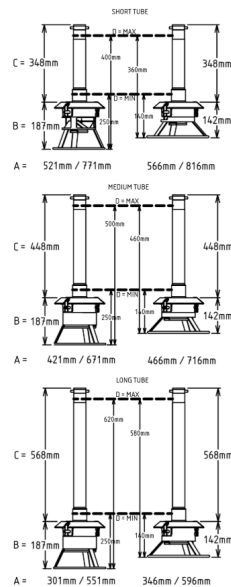

EI = Electrical inlet (power)



Find out more:  
ISO Certificates  
Electrolux Professional Recognitions

The company reserves the right to make modifications to the products without prior notice. All information correct at time of printing.

2026/06/16

3/3