



Electrolux

Vegetable Slicer TRS Vegetable Slicer - 1 Speed - 500W - UK plug

ITEM # _____

MODEL # _____

NAME # _____

SIS # _____

AIA # _____



Electrolux



Vegetable Slicer

TRS Vegetable Slicer - 1 Speed - 500W - UK plug

603357 (TRS1V501G)

Vegetable slicer, 1 speed 360 rpm, 500 W. Lever operated hopper in stainless steel for intense use (UK)

Short Form Specification

Item No.

Universal vegetable slicer for more than 80 different types of cuts, thanks to more than 40 stainless steel dw safe discs.

Parts in contact with food - stainless steel lever, stainless steel hopper and cutting chamber - can be removed without tools and placed in a dishwasher for fast cleaning.

Compact and ergonomic design, user-friendly lever (better pressure control, with less effort for arms and shoulder), designed for right and left handed users.

Angled base (20°) facilitates loading and unloading operations. Long vegetable hopper (60mm diameter), integrated in the wide 3/4 moon round hopper (215cm²) in stainless steel. Asynchronous industrial motor for heavy duty and longer life. High discharge zone (up to 20cm) for GN containers. 1 speed (360rpm) and pulse control for precise slicing. Automatic start/stop function will stop the machine when the lever hopper is lifted and will restart automatically when lowered. Waterproof control panel and aluminium alloy motor base completely closed for complete protection against strong jets of water. UK plug

Main Features

- Suitable for 100-400 meals for table service and up to 800 meals for catering service.
- Vegetable slicer unit has slicing, grating, shredding as well as dicing and french fries capabilities.
- Delivered with:
 - All stainless steel vegetable prep attachment with a lever-integrated long vegetable hopper (60mm diameter) and a large round hopper (215cm²).
- Ergonomically designed for right and left-handed users, frontal working and to reduce working space around the machine.
- All parts in contact with food are removable without the use of tools, stainless steel hopper, stainless steel lever and cutting chamber are dishwasher safe.
- Hopper easily removed for cleaning.
- High discharge zone permits the use of deep GN containers (up to 20cm).
- Complete and wide selection of blades and grids available (diam. 205 mm)
- Pulse function for precise cutting.
- Magnetic safety system and motor brake. Prevents machine from running when pusher plate swings away or is open.
- Automatic restart of the machine with the 3/4 moon shaped pusher in position.
- Continuous feed model.
- Base inclined at 20° to provide easy loading and unloading.

Construction

- All blades (available on request) are made in stainless steel and dishwasher safe.
- IP55 flat and waterproof control panel, IP24 throughout the entire machine.
- 1 speed: 340 rpm
- Power: 500 W - single or three-phase.
- Compact and portable design.
- Asynchronous industrial motor for heavy duty and longer life.
- Feeding arm and hopper are made entirely in stainless steel. Aluminum motor housing.

APPROVAL: _____



Electrolux

Vegetable Slicer TRS Vegetable Slicer - 1 Speed - 500W - UK plug

Included Accessories

- 1 of Ejector disc PNC 653772

Optional Accessories

- Stainless steel pressing/slicing disc with S-blades (balanced) 5 mm (can be used for slicing or combined with grids) PNC 650048
- Stainless steel pressing/slicing disc with S-blades (balanced) 6 mm (can be used for slicing or combined with grids) PNC 650049
- Stainless steel pressing/slicing disc with S-blades (balanced) 8 mm (can be used for slicing or combined with grids) PNC 650050
- Stainless steel pressing/slicing disc with S-blades (balanced) 10 mm (can be used for slicing or combined with grids) PNC 650051
- Stainless steel pressing/slicing disc with S-blades (balanced) 10 mm (can be used for slicing or combined with grids) PNC 650052
- Stainless steel pressing/slicing disc with S-blades (balanced) 12 mm (can be used for slicing or combined with grids) PNC 650053
- Stainless steel pressing/slicing disc with S-blades (balanced) 13 mm (can be used for slicing or combined with grids) PNC 650054
- Stainless steel pressing/slicing disc with corrugated S-blades (balanced) 8 mm (can be used for slicing or combined with grids) PNC 650055
- Stainless steel pressing/slicing disc with corrugated S-blades (balanced) 10 mm (can be used for slicing or combined with grids) PNC 650056
- Stainless steel work table with folding shelves and disk rack PNC 653283
- Dicing grid 5x5 mm PNC 653566
- Dicing grid 8x8 mm PNC 653567
- Dicing grid 10x10 mm PNC 653568
- Dicing grid 12x12 mm PNC 653569
- Dicing grid 20x20 mm PNC 653570
- Grid for chips 6x6 mm PNC 653571
- Grid for chips 8x8 mm PNC 653572
- Grid for chips 10x10 mm PNC 653573
- Stainless steel slicing disc with S-blades 0,6 mm PNC 653728
- Stainless steel slicing disc with S-blades 1 mm PNC 653729
- Stainless steel slicing disc with S-blades 2 mm PNC 653730
- Stainless steel slicing disc with S-blades 3 mm PNC 653731
- Stainless steel slicing disc with S-blades 4 mm PNC 653732
- Stainless steel slicing disc with S-blades 5 mm PNC 653733
- Stainless steel slicing disc with S-blades 6 mm PNC 653735
- Stainless steel slicing disc with S-blades 8 mm PNC 653737
- Stainless steel shredding disc with S-blades 2x2 mm PNC 653743
- Stainless steel shredding disc with S-blades 3x3 mm PNC 653744
- Stainless steel shredding disc with S-blades 4x4 mm PNC 653745
- Stainless steel shredding disc with S-blades 6x6 mm (can also be used for chips) PNC 653746
- Stainless steel shredding disc with S-blades 8x8 mm (can also be used for chips) PNC 653747
- Stainless steel shredding disc with S-blades 10x10 mm (can also be used for chips) PNC 653748

- Stainless steel disc with corrugated S-blades 2 mm PNC 653749
- Stainless steel disc with corrugated S-blades 3 mm PNC 653750
- Stainless steel disc with corrugated S-blades 6 mm PNC 653751
- Stainless steel grating disc 2 mm PNC 653773
- Stainless steel grating disc 3 mm PNC 653774
- Stainless steel grating disc 4 mm PNC 653775
- Stainless steel grating disc 7 mm PNC 653776
- Stainless steel grating disc 9 mm PNC 653777
- Stainless steel grating disc for knoedeln and bread PNC 653778
- Stainless steel grating disc for parmesan and bread PNC 653779
- Bistrot Pack-set stainless steel discs (C2S-2mm slicing disc, C5S-5mm slicing disc, J2X-2mm grating disc) PNC 653785
- Gastronomy Pack-set stainless steel discs (C2S-2mm slicing disc, C5S-5mm slicing disc, J2X-2mm grating disc, AS4X-4x4mm shredding disc, C10PS-10mm presser/slicer, MT10T-10x10mm dicing grid) PNC 653786



Vegetable Slicer
TRS Vegetable Slicer - 1 Speed - 500W - UK plug

The company reserves the right to make modifications to the products without prior notice. All information correct at time of printing.



Electrolux

Vegetable Slicer TRS Vegetable Slicer - 1 Speed - 500W - UK plug

Front

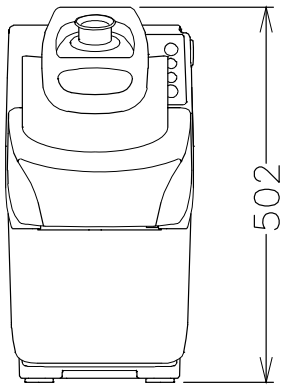

Top

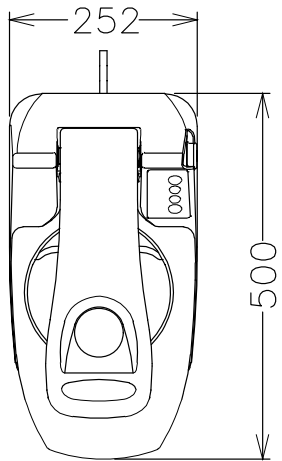

EI = Electrical connection

Side

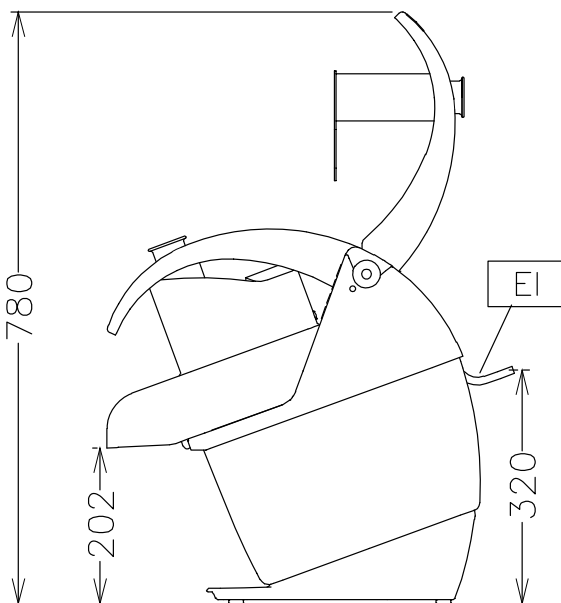

Electric

Supply voltage:

603357 (TRS1V501G) 220...240 V/1N ph/50 Hz

Connected load:

0.5 kW

Total Watts:

0.5 kW

Capacity

Performance (up to):

550 - kg/hour

Key Information

External dimensions, Height 502 mm

External dimensions, Width 252 mm

External dimensions, Depth 500 mm

Shipping weight: 24 kg



Vegetable Slicer
TRS Vegetable Slicer - 1 Speed - 500W - UK plug

The company reserves the right to make modifications to the products without prior notice. All information correct at time of printing.

2014.06.24