

You are what you eat

L. Feuerbach, philosophe Allemand, 1804-1872

Feuerbach left his mark on this maxim when putting the finishing touches to a book about nutrition in 1850.

He was right of course: what we eat makes us what we are, or what we will be in the near future. And it's not just the appetizing appearance of food that is a deciding factor, but its nutritional value and the vitamins it contains.

COOKING HOB

INDUCTION

Instructions for use

1. Contents	2
2. Introduction	3
3. Safety instructions	4
4. Before starting up for first time	7
5. Functions and settings	8
6. Hints and tips	9
7. Troubleshooting	9
8. Cleaning	10
9. Regulations	11
10. Compliance	11
11. Technical specifications	12
12. Installation diagram	13

2. INTRODUCTION

2.1 Overview

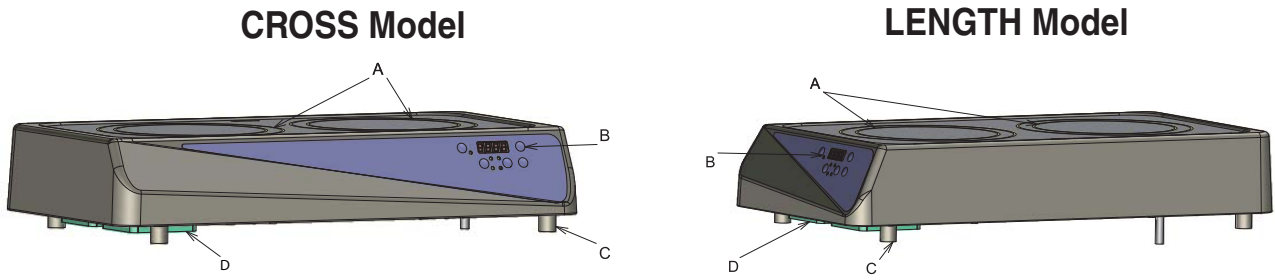

A: Hot plate - B: Control panel - C: Feet - D: Filter

2.2 Control panel

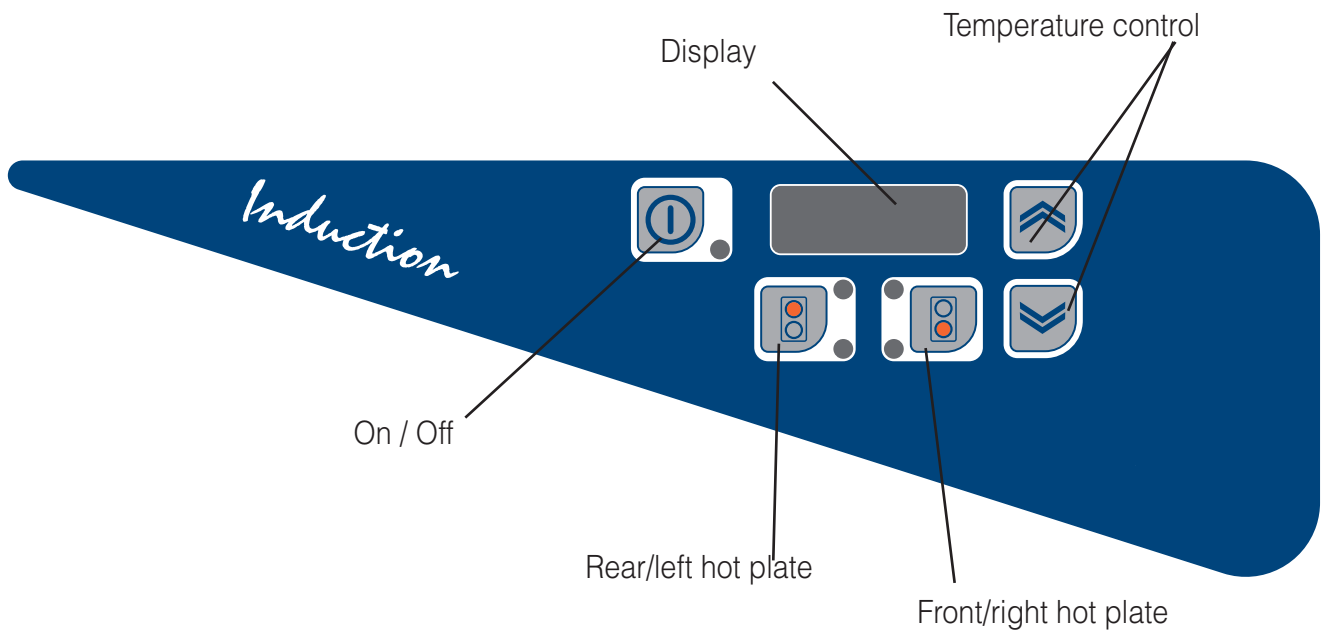

3. SAFETY INSTRUCTIONS

Read these instructions carefully and keep them in a safe place; they have been written to help you to use your infrared cooker in the best possible way. You must comply with the safety recommendations that are shown by a:



3.1 Electrical safety



- Check that the data given on the rating plate of the appliance are compatible with the mains voltage and frequency.
- The appliance must be connected up to a waterproof, standardised 16A 2 pin + earth wall socket.
- The installation must be protected by a 30 mA differential circuit breaker and a 16A switching device. (fuse or circuit breaker).



The appliance must be earthed



Do not use any dividers, adaptors or branch joins for the connection because these may result in faulty contacts and dangerous overheating.

Any type of incorrect installation or modification is liable to cause material or bodily damage.

If your appliance has any defect whatsoever, we advise you not to use it.

Disconnect the appliance from the socket or remove the fuse or disconnect the switch/breaker from the circuit it is connected to.

If you have any operating problems, refer in the first instance to the “Hints and tips” section of this document. If the problem persists, please contact our technical assistance department. Do not try to repair the appliance yourself as this could lead to further problems.

3.2 General safety

- If the glass ceramic surface / glass surface is cracked, switch off the appliance to avoid the possibility of electric shock.
- Aluminum foil and plastic containers should not be placed on hot surfaces.
- Do not store items on the cooking surfaces.
- Metallic objects such as knives, forks, spoons and lids should not be placed on the hob surface since they can get hot
- Be careful when using the appliance, objects worn by the user such as rings, watches and similar items that may become hot when placed very near the hob.
- Use only containers of the type and size recommended
- Pacemaker wearers must remain a minimum distance of 30 cm from induction cooking zones when the unit is in operation.
- All repairs must be performed only by trained and qualified persons or recommended by the manufacturer.
- If the supply cord is damaged, it must be replaced by the manufacturer, an authorized Service or similarly qualified persons in order to avoid a hazard.
- Do not operate the appliance by means of an external timer or separate remote-control system.



BE CAREFUL – MAGNETIC FIELD

3.3 Topple prevention

- The appliance must be placed on a work surface, preferably of a height of between 800 and 900 mm for comfort of use.
- The appliance has four adjustable feet (👁️ 2.1). Make sure the appliance is stable and horizontal by screwing or unscrewing the feet.

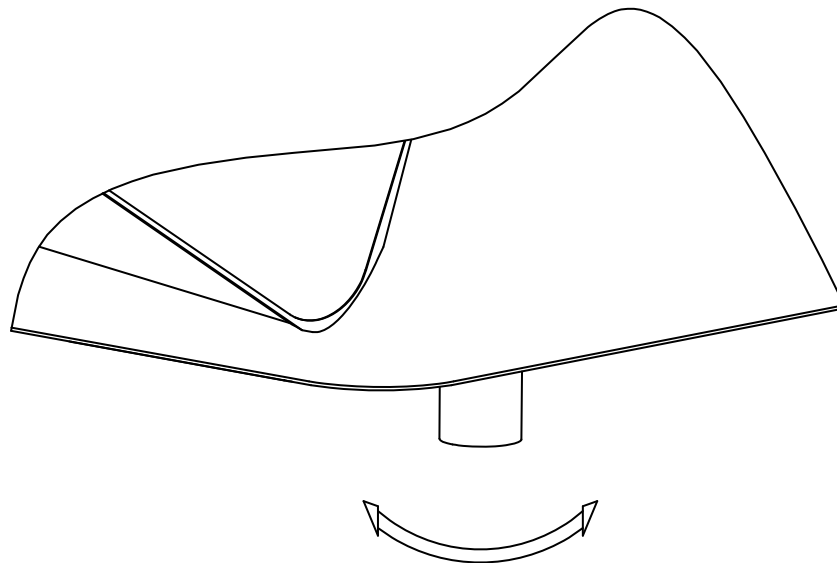

3.4 Position of the appliance

- The appliance can be fitted in between two elements of a type that will be compatible with any splashes of fat from cooking. However, it is necessary to leave a space between the appliance and other elements nearby to be able to clean.

IMPORTANT :

To ensure correct ventilation and therefore proper cooling down, you must make sure there is a distance of 50 mm between the rear of the appliance and the wall (or other).



3.5 Use

Curtains, tea cloths, cutting boards and other objects made of wood must always be kept at a distance, as must containers holding alcohol, solvents or inflammable cleaning products. Never try to put out an electrical fire with water: use fire extinguisher products or appropriate extinguishers after cutting off the power!



The plate gets very hot: do not put your hands on it!



Warning! The sides and handles of containers may reach very high temperatures. The handles must be touched with care using a protective cloth or gloves.

- Caution! In order not to affect correct operation, the use of pans with a base that is not perfectly flat must be avoided at all costs.

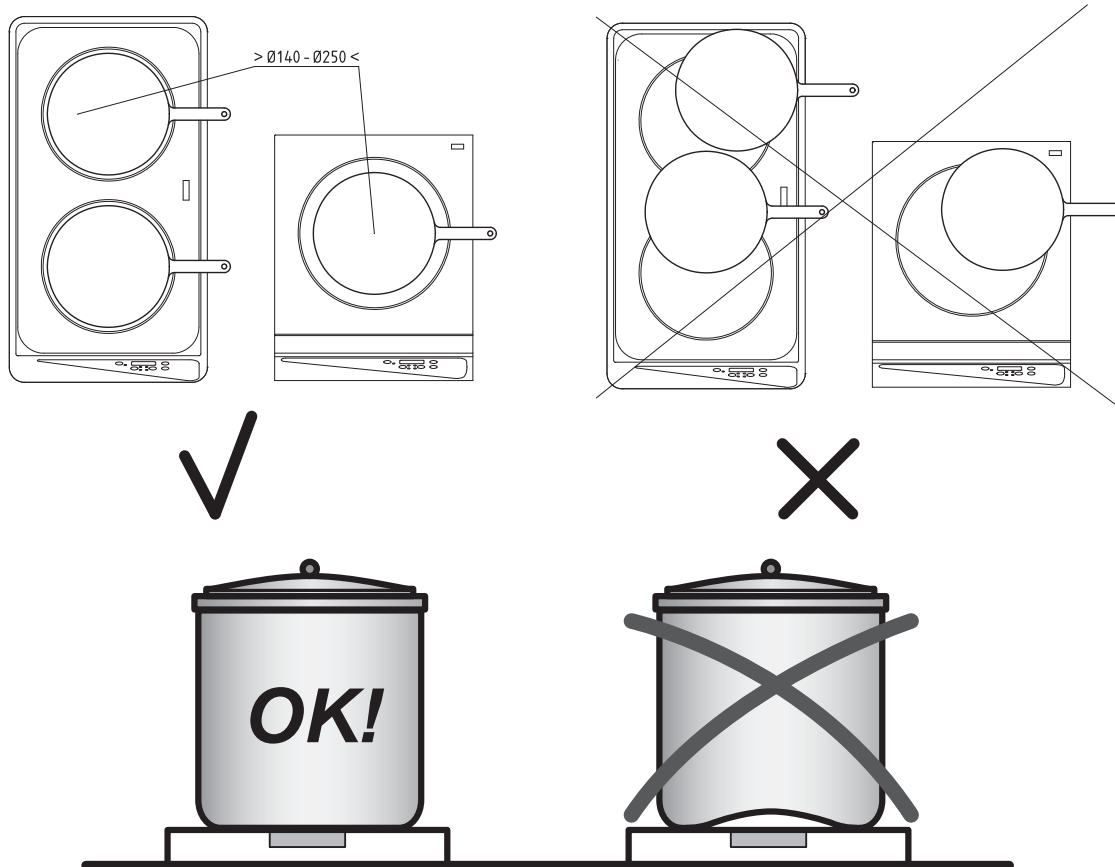

- Do not put empty frying pans or saucepans on the appliance because the temperature rises very quickly.
- Never put any other items than cooking pans on the appliance. The high temperature might cause burns or destroy the appliance.

3.6 Cleaning

 Before cleaning the appliance, make sure that the glass has cooled down sufficiently. Protect your arms and keep your face away to avoid burns.

 Never put the appliance in the dishwasher or immerse it in water to wash it. Before any cleaning operation, disconnect the appliance from the power supply.

3.7 Accessories

In addition to the accessories that come with the appliance, you are advised to use heat-resistant spatulas. 

4. BEFORE USING THE APPLIANCE FOR THE FIRST TIME —

- Wash the glass with soapy water and rinse thoroughly.
The appliance is ready for use.

5. FUNCTIONS AND SETTINGS

The temperature of the hot plate is the only thing that needs setting. There are several setting modes.

5.1a Starting the Double Zone appliance

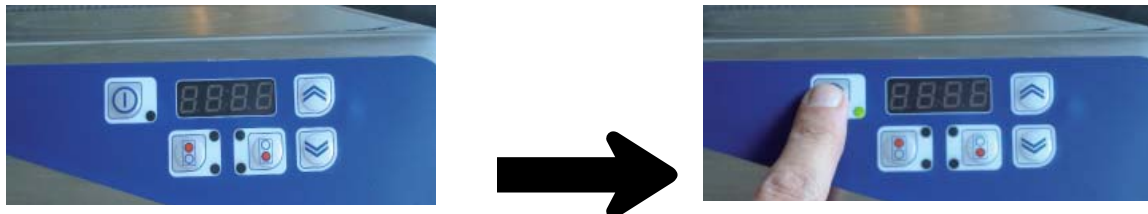



Start the appliance using the On key .

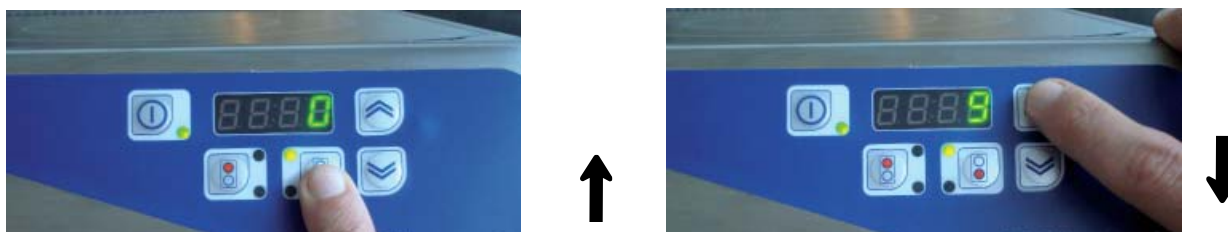

5.2a Setting the power in manual mode



You can adjust the power at any time using the keys  .

5.3a Setting the power level of the selected zone

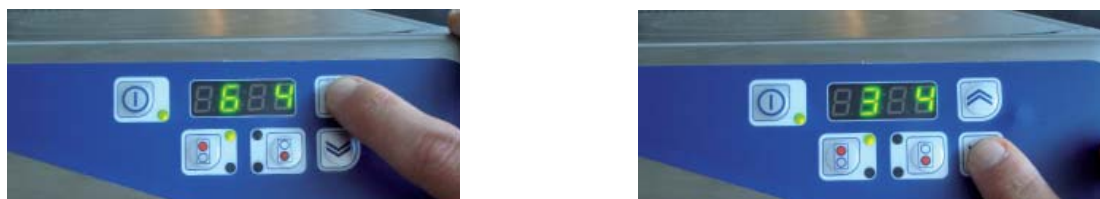

To reach the maximum power level of 12, press the key  for the zone selected.

5.5a Stopping the machine



Press the key  to stop the appliance.



Nota : When boost an area full power the other zone is disabled.



Nota : The fans may carry on working for a few minutes even if the appliance is stopped. This is normal and is to ensure the inner parts cool down properly.
DO NOT UNPLUG the appliance during this phase as that could damage the appliance.

6. HINTS AND TIPS

Work rules

The food is placed over the activated surface area of glass plate A and is subjected to intensive heat by thermal conductivity generated on contact with the plate.

7. TROUBLESHOOTING

You are advised to check the following points before calling a technician.

Problems	Causes	Solutions
The appliance does not work, the indicator lamp 2 remains off.	No power supply	<ul style="list-style-type: none">• Check that the appliance is plugged in.• Check that the electrical power supply to the socket is correct.
The appliance does not work, the indicator lamp 2 remains on.	faulty heat element or faulty electronic card	<ul style="list-style-type: none">• see with maintenance department
Vibration noise	Foreign body in the fans	<ul style="list-style-type: none">• Check the presence of fan filters.

8. CLEANING

1. EXTERNAL PARTS

(with every use)

- Remove soiling, fat and food residue that remain on the steel surfaces using a cloth or sponge soaked in soapy water, with or without detergent.

Carefully rinse and wipe all surfaces that have been washed.

- Do not use metal sponges, abrasive powders or aggressive chemical products such as sodium hypochlorite (bleach), hydrochloric acid (hydrogen chloride) or other acids to clean these surfaces; these products result in irreversible corrosion of the steel in a very short time. Never use these products, even to clean adjoining areas, in order to avoid damage to the steel by any vapours given off.

VITROCERAMIC SURFACES

- Clean the vitroceramic top using a paper serviette soaked in a specific detergent for glass; rinse the top, then dry with a clean and dry cloth.
- Do not clean the top when hot.
- Immediately remove any pieces of aluminium foil from the cooking zone, to avoid damaging the induction device.

- **Every month:**

Check the condition of the air filters (under the appliance). Change them, if necessary.

The air filters must be clean in order to guarantee correct operation of the appliance.

2. PERIODS OF DISUSE

If the appliance is not going to be used for some time, take the following precautions:

- Close any cocks or main switches installed ahead of the appliances.
- Go over all dry s/steel surfaces vigorously with a cloth soaked in paraffin oil or similar products available on the market in order to spread a protective film against dirt and damp.
- Air the room periodically.
- Have the appliance checked before using it again.
- In order to avoid too rapid evaporation of accumulated moisture and consequent breakage of the element, when starting up again leave the electric appliances on minimum setting for at least 45 minutes.

3. INTERIOR COMPONENTS (every 6 months)

Important! Operations to be carried out exclusively by specialized technicians.

- **Check the condition of internal parts.**
- **Remove any deposits of dirt inside the appliance.**
- **Check and clean the flue system.**

N.B! In particular ambient conditions (e.g. intensive use of the appliance, salty environment, etc.) the above cleaning should be more frequent.

9. REGULATIONS

Environnement

- The packaging materials are environment-friendly.
- Our appliances guarantee high performance and productivity. To reduce electricity consumption, do not operate the appliance empty or under conditions that could damage its performance. If possible, preheat for just 10 to 15 min. before use.
- In order to reduce the emission of polluting substances into the environment, you are advised to clean the appliance (outside and, if required, inside) with products that are more than 90 % biodegradable (for further details, see section 8 “CLEANING”).



Disposal

Do not dispose of into the environment.

Our appliances are made with metal materials (stainless steel, iron, aluminium, galvanised sheet iron, copper, etc.) that can be recycled to more than 90 % of their weight.

When disposing of the appliance, put it out of use by cutting its power cord.

The symbol  shown on the appliance indicates that it must not be considered as household waste and it must be correctly disposed of to prevent any negative impact on the environment or human health.

For further information on the recycling of this appliance, contact the local agent or product dealer, the after-sales assistance department or the local organisation qualified to dispose of waste.

10. COMPLIANCE

Integrated security / Hygiene / Environment

- CEM directive 2014/ 30/ EU
- 2011/65/EU Directive on the restriction of the use of certain hazardous substances
- WEEE directive 2002/96/EC
- «Waste» directive 2006/12/EC

Please comply with the recycling conditions.

- “Packaging and packaging waste” directive 94/62/EC

The machine packaging is designed in order to contribute as little as possible, if at all, to the quantity and noxious nature of waste and risks of pollution.

Please make sure the various packaging materials are disposed of in the appropriate recycling points.

The machine is made of materials that comply with the following legislation and standards:

- Directive 2007/19/EC: materials and articles intended to come in contact with food,
- Standard EN 1672-2-2005: Instructions relating to hygiene.

The surfaces of the food area are smooth and easy to clean. Use detergents that are approved for food hygiene and respect the instructions for their use.

- Standards:

EN 60335-1: Electric and electronic household appliances and similar: General safety requirements.

EN 60335-2-36 : Electric and electronic household appliances and similar: Specific rules relating to electrical griddle plates for collective use.

This compliance is certified by:

- The CE conformity mark, attached to the machine.
- The corresponding CE declaration of conformity, associated with the warranty.
- This instruction manual which must be given to the operator.

11. TECHNICAL SPECIFICATIONS

Power supplySingle phase 50/60 Hz voltage adapted to country of use

PlugSingle phase + earth adapted to sockets in the country of use

Electricity consumption

Consumption when heating.....3600 W Double zone

Consumption when heating.....3200 W Mono zone

Dimensions

Height 122 mm

	Cross	Lenght
Width.....	600	352
Depth	352	600

Net weight..... 14 Kg Double Zone -

12. INSTALLATION DIAGRAMS

LENGHT

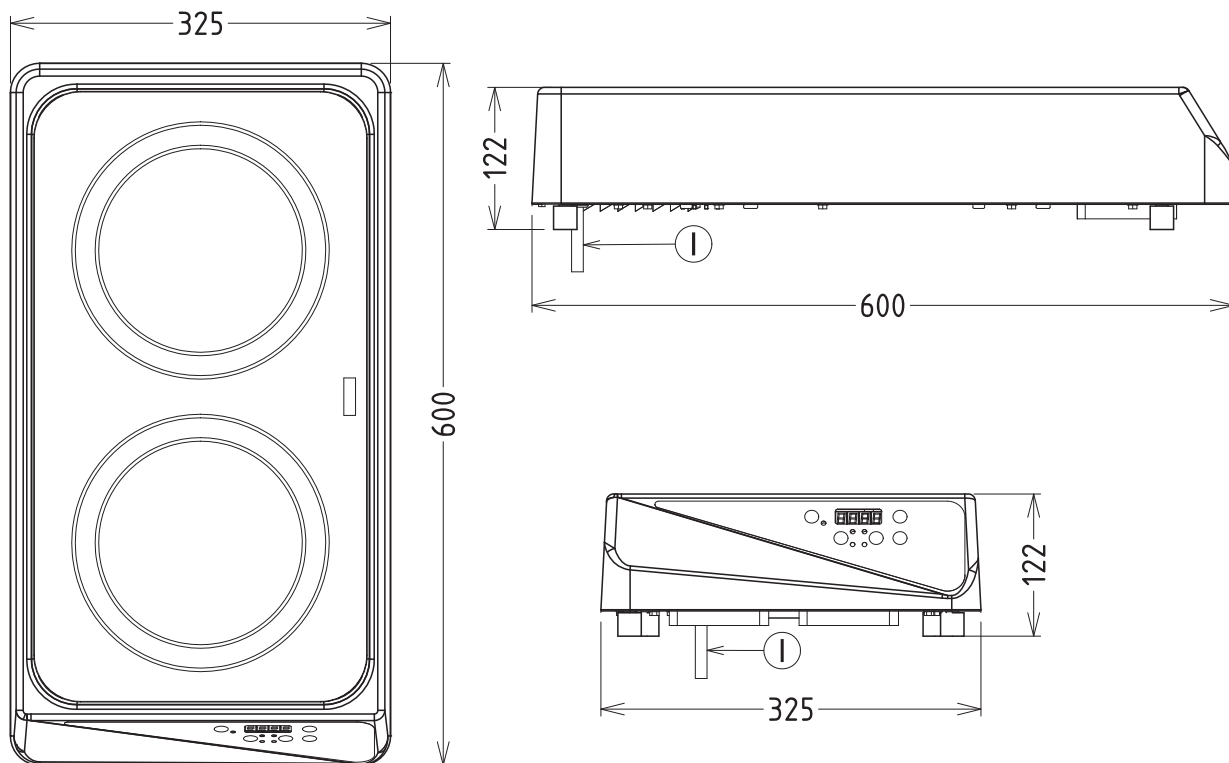

CROSS

