



Electrolux

Food Processor Cutter Mixer 2,5 LT - Single Speed - UK Plug

ITEM # _____

MODEL # _____

NAME # _____

SIS # _____

AIA # _____



Electrolux



Food Processor

Cutter Mixer 2,5 LT - Single Speed - UK Plug

603837 (K25YG)

Table mounted cutter mixer, 2,5 litre capacity with stainless steel bowl and a single speed of 1500 rpm. Supplied with smooth blade rotor (UK)

Main Features

- Direct shaft drive.
- Delivered with:
- 2,5 liter stainless steel bowl with smooth edge "S" blade included.
- Red OFF, green ON and PULSE buttons.
- Magnetic safety system and motor brake. Prevents machine from running when bowl lid swings away from magnetic switch or is open.
- Parts in contact with food are removable and dishwasher safe.
- Pulse function to coarse chopping.
- Productivity suitable for 10-50 meals per service.

Construction

- Power: 370 watts.
- Speed motor: 1.500 rpm.
- IP55 waterproof control panel.
- All polycarbonate plastic, stainless steel bowl and transparent lid with central hole to add ingredients during the preparations.
- Compact and portable design.

Included Accessories

- 1 of Smooth blade rotor PNC 653146
- 1 of 3 litre stainless steel bowl for cutter mixer PNC 653487

Optional Accessories

- Microtooth blade rotor for 2,5 lt cutter mixer PNC 650035
- Cutter equipment (stainless steel bowl, lid, and rotor) PNC 653047
- Smooth blade rotor PNC 653146
- 3 litre stainless steel bowl for cutter mixer PNC 653487
- Polycarbonate lid for vegetable cutters (K25 and Multigreen). PNC 653512

APPROVAL: _____



Electrolux

Food Processor Cutter Mixer 2,5 LT - Single Speed - UK Plug

Front

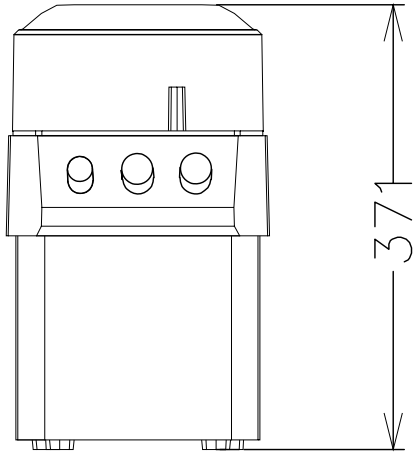

Top

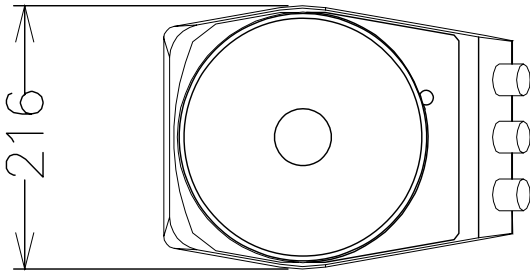

EI = Electrical connection

Side

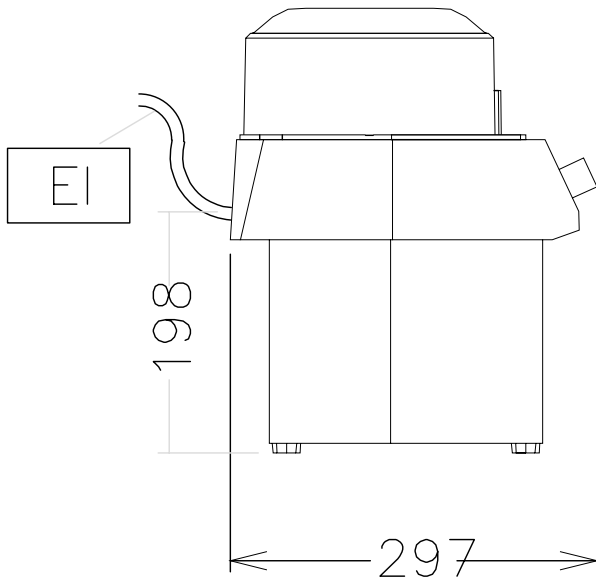

Electric

Supply voltage:

603837 (K25YG) 230 V/1N ph/50 Hz

Connected load:

0.37 kW

Total Watts:

0.37 kW

Capacity

Performance (up to):

1 - kg/Cycle

Capacity

2.5 liter

Key Information

External dimensions, Height 371 mm

External dimensions, Width 216 mm

External dimensions, Depth 297 mm

Shipping weight: 17 kg



**Food Processor
Cutter Mixer 2,5 LT - Single Speed - UK Plug**

The company reserves the right to make modifications to the products without prior notice. All information correct at time of printing.

2014.06.24