

Digital Undercounter Freezer Counter - 2 Door (R290), with upstand, wheels and UK plug

ITEM # _____

MODEL # _____

NAME # _____

SIS # _____

AIA # _____

710479 (EJ2KBAAXXG)

2-door Freezer Counter, -22-15°C, AISI 304 (R290), with splashback and wheels - UK plug

Short Form Specification

Item No.

Internal and external doors, front and side panels in 304 AISI stainless steel. N.2 doors. With top with upstand. Built-in refrigeration unit. Ventilated. Refrigerant R290. High-density expanded polyurethane foam, 90 mm in thickness, with cyclopentane injection. Digital control panel. Completely automatic defrosting and automatic evaporation of defrost water obtained by hot gas. Temperature range: -15/-22°C. CFC and HCFC free. Feet in 304 AISI stainless steel, adjustable in height. Delivered with wheels and with UK plug.

Main Features

- Anti-tilt runners accept GN 1/1 containers.
- Combination of doors and drawers to suit varying needs, with the possibility to change the configuration on site.
- Digital control panel.
- Forced air circulation for rapid cooling and an even temperature distribution.
- Refrigerated compartment designed to accept GN 1/1 containers.
- Adjustable temperature range from -15 °C to -22 °C to suit meat, fish and dairy storage requirements.
- Self closing stainless steel doors (< 90°).
- Fully compliant HACCP digital control: when temperature exceeds critical limits, acoustic and visual alarms are activated. Up to two months of event are kept in memory.
- Prearranged to fit RS485 port to facilitate connection to a remote computer and integrated HACCP systems.
- Tropicalized unit (43°C ambient temperature).
- 0mm clearance installation space: tower configuration cooling unit guarantee performance with frontal ventilation only; this unique solution allows installation against the wall or side by side with other appliances, even on the cooling unit side to maximize the use of kitchen space.
- Hot gas automatic evaporation of defrost water.
- Preservation performances and temperature uniformity within the cell guaranteed at 5-HEAVY DUTY (40°C) working conditions according to EN16825:2016 test protocol.
- Combination of doors and drawers to suit any configuration needed, with the possibility to change the configuration on site. Right cooling unit available on request.
- Frontal and easy access to all components in the cooling unit.
- Mounted on stainless steel feet to give 150 mm (-5/+50 mm) clearance for ease of cleaning the floor.
- Certified safety CE requirements.
- Small footprint to fit even in limited environments.
- Connectivity ready for real time access to connected appliances from remote and data monitoring (requires optional accessory).
- Easy serviceability thanks to the intuitive control panel with remote access via app.
- Integrated RS485 port to facilitate connection to a remote computer and integrated HACCP systems.

APPROVAL: _____

Construction

- Access to all components from the front.
- Built-in compressor to suit operating conditions.
- Developed and produced in ISO 9001 and ISO 14001 certified factory.
- Fault code display.
- Interior base with rounded corners, pressed from a single sheet.
- Internal and external doors, front, back and side panels in AISI 304 Stainless steel.
- Mounted on Stainless steel adjustable legs to give 150 mm clearance for ease of cleaning.
- Rounded internal corners for ease of cleaning.
- Pre-arranged for drain-pipe.
- Built-in refrigeration unit.
- Ease of cleaning and high hygiene standards thanks to the rounded internal corners, the easily removable runners, grids and air conveyors.
- Internal structure with 15 charging positions (3 cm pitch) available to host GN 1/1 grids, ensuring higher net capacity and a greater storage space.
- Extractable cooling unit to facilitate maintenance.
- IP21 protection index.

Included Accessories

- 2 of Kit 1/1 grey rilsan grid and 2 side runners for refrigerated counters PNC 881109

Optional Accessories

- 1/1GN grey rilsan grid for refrigerated counters PNC 881107
- 2 side runners for 1/1 GN ecostore refrigerated counters PNC 881108
- Kit 1/1 grey rilsan grid and 2 side runners for refrigerated counters PNC 881109
- 1/1 GN plastic container, H=65 mm PNC 881110
- 1/1 GN plastic container, H=100 mm PNC 881111
- 1/1 GN plastic container, H=150 mm PNC 881112
- 2x½ drawer kit for refrigerated counters - h650mm PNC 881176
- Kit 4 wheels, H=100 mm (2 with brakes) for refrigerated counters PNC 881191
- Kit 4 wheels, H=150 mm (2 with brakes) for 2&3 compartment refrigerated counters PNC 881193
- Lock for refrigerator/freezer counters with 2 compartments - h650mm (can be used in kit for Marine conversion) PNC 881245
- Kit 4 (45mm) spacers for wheels for refrigerator/freezer counters PNC 881277

Digital Undercounter Freezer Counter - 2 Door (R290), with upstand, wheels and UK plug

Front

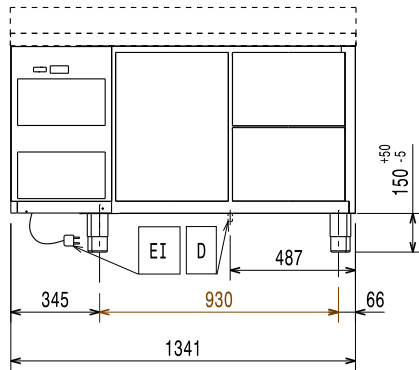

Side

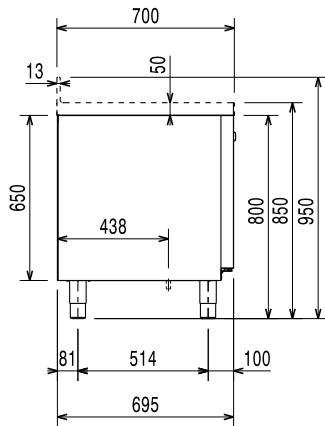

EI = Electrical inlet (power)

Top

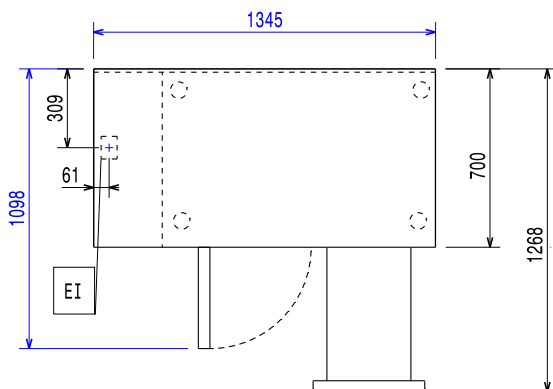

Electric

Supply voltage:	710479 (EJ2KBAAXXG)	220-240 V/1 ph/50 Hz
Electrical power max.:		0.49 kW

Key Information:

Gross capacity:	
Net Volume:	160 lt
N° of doors:	
Built-in Compressor and Refrigeration Unit	
External dimensions, Width:	1345 mm
External dimensions, Depth:	700 mm
External dimensions, Height:	950 mm
Internal Dimensions, Width:	798 mm
Internal Dimensions, Depth:	560 mm
Internal Dimensions, Height:	550 mm
Net weight:	105 kg
Shipping volume:	1.08 m ³
Depth with doors open:	1310 mm

Refrigeration Data

Control type:	Digital
Compressor power:	3/4 hp
Min/Max internal humidity:	
Operating temperature min.:	-15 °C
Operating temperature max.:	-22 °C
Operating mode:	Ventilated

Sustainability

Energy Class (EU Reg. 2015/1094):	C
Yearly and daily energy consumption (EU Reg. 2015/1094):	1600kWh/year - 4kWh/24h
Climate class (EU Reg. 2015/1094):	Heavy Duty (5)
Energy Efficiency Index-EEI (EU Reg. 2015/1094):	48.27
Refrigerant type:	R290
GWP Index:	3
Refrigeration power:	569 W
Refrigerant weight:	140 g

Digital Undercounter
Freezer Counter - 2 Door (R290), with upstand, wheels and UK plug

The company reserves the right to make modifications to the products without prior notice. All information correct at time of printing.

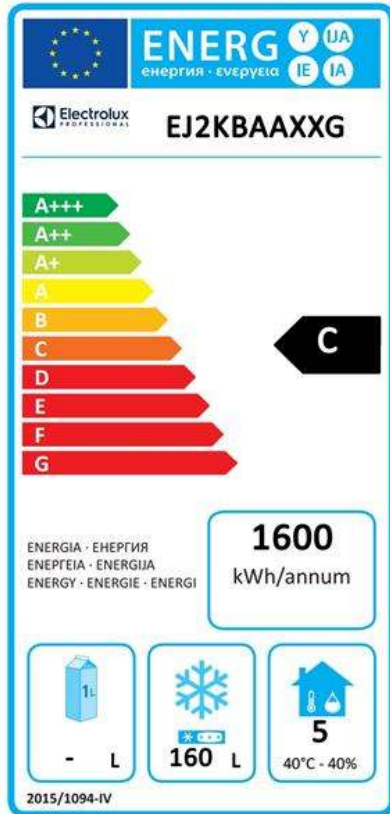

EU energy labelling from 1st July 2016

The European energy labelling scheme for professional refrigerators and freezers is based on requirements setting Minimum Energy Performance standards for commercial refrigeration cabinets sold within the EU.

These requirements are designed to drive energy efficiency and environmentally friendly approach for professionals. The European energy labelling scheme will apply to all manufacturers and importers who sell and market products within the EU and it is mandatory across Europe. Important: all products which consume energy above the minimum level will not be able to be sold within the EU from 1 July 2016.

SI 2020 No. 1528.

Important: all products which consume energy above the minimum level will not be able to be sold within the EU from 1 July 2016.

