



Electrolux

## Digital Undercounter Heavy Duty Freezer - 77 gal (290 lt) 2 Door - Splashback

ITEM # \_\_\_\_\_

MODEL # \_\_\_\_\_

NAME # \_\_\_\_\_

SIS # \_\_\_\_\_

AIA # \_\_\_\_\_



Electrolux



### Digital Undercounter

### Heavy Duty Freezer - 77 gal (290 lt) 2 Door - Splashback

726578 (RCDF2M20U)

Heavy Duty Digital Undercounter Freezer - 77 gal (290 lt) 2 Door with Splashback 230 V/1N/50Hz

### Short Form Specification

#### Item No.

External and internal in AISI 304 stainless steel. Worktop, thickness mm50, fitted with integrated rear upstand mm100h. Insulation thickness mm60. N. 2 full doors. Built-in refrigeration unit. Ventilated operating mode. Evaporator. Electronic microprocessor control with external digital temperature display. Automatic defrost. Operating temperature: -18-24°C. For ambient temperatures up to 43 °C. CFC and HCFC free. R404a gas in refrigeration circuit. Gas in foam: Cyclopentane.

Supplied with n. 2X1/1GN Rilsan coated grids and n. 8 sets of 2 stainless steel grid runners.

### Main Features

- Suitable for use in ambient temperatures of up to 43 °C.
- Adjustable temperature range from -15 °C to -22 °C to suit meat, fish and dairy storage requirements.
- Anti-tilt runners accept GN 1/1 containers.
- Combination of doors and drawers to suit varying needs, with the possibility to change the configuration on site.
- Electronic microprocessor control with external digital temperature display.
- Forced air circulation for rapid cooling and an even temperature distribution.
- CFC and HCFC free (ecological refrigerant type: R404a, - gas in foam: cyclopentane).
- 60 mm insulation for energy saving.
- Raised rear splashback permits unit to be connected up against the wall for better hygiene.

### Construction

- Mounted on legs with height adjustment.
- Built-in compressor to suit operating conditions.
- Constructed from AISI 304 Stainless steel throughout to meet the highest hygiene standards.
- Rounded internal corners for ease of cleaning.
- Mounted on Stainless steel legs to give 150 mm clearance for ease of cleaning the floor.
- Worktop in AISI 304 Stainless steel with a 50 mm thickness.
- Access to all components from the front.
- Developed and produced in ISO 9001 and ISO 14001 certified factory.

### Included Accessories

- 2 of 1/1GN grey rilsan grid PNC 881435

### Optional Accessories

- 1/1GN plastic container h=100mm PNC 811451
- 1/1GN plastic container h=65mm PNC 881038
- 1/1GN plastic container h=150mm PNC 881040
- 1/1GN grey rilsan grid PNC 881435
- Lock for refrigerated counters PNC 881499
- Kit 1 door for refrigerated counter PNC 881517

APPROVAL: \_\_\_\_\_



Electrolux

# Digital Undercounter Heavy Duty Freezer - 77 gal (290 lt) 2 Door - Splashback

Front

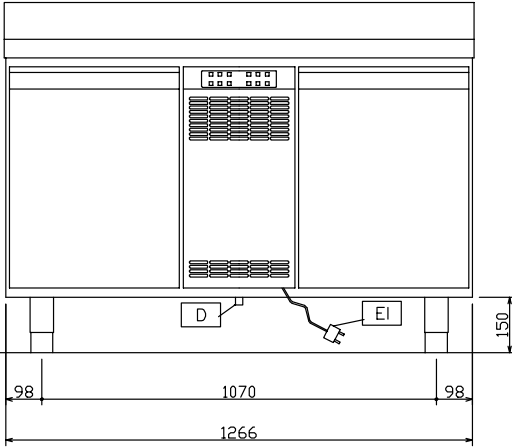

Top

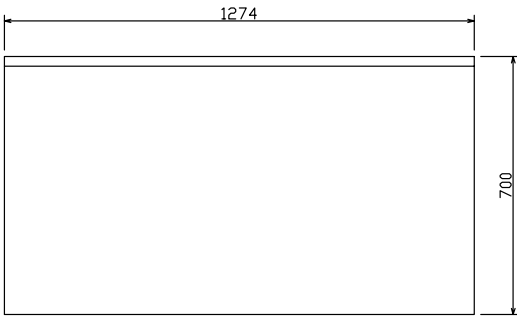

EI = Electrical connection

Side

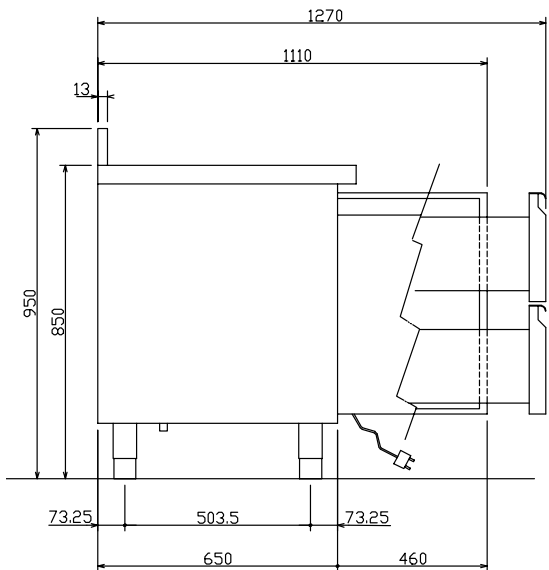

## Electric

Supply voltage:

726578(RCDFM20U)

230 V/1N ph/50 Hz

## Key Information:

Door hinges: 1 Left+1 Right

Built-in Compressor and Refrigeration Unit

External dimensions, Height: 950 mm

External dimensions, Width: 1274 mm

External dimensions, Depth: 700 mm

External dimensions, Weight: 130 kg

Number and type of doors: 2

Depth with doors open: 1110 mm

Height adjustment: -10/50 mm

Number and type of grids (included): 2 - GN 1/1

## Refrigeration Data

Compressor power: 3/4 hp

Refrigerant type: R404a

Refrigeration power: 925 W

Refrigerant weight: 280 g



Digital Undercounter Heavy Duty Freezer - 77 gal (290 lt) 2 Door - Splashback

The company reserves the right to make modifications to the products without prior notice. All information correct at time of printing.

2009.10.24