



Electrolux

ecostore
2 Door Digital Stainless Steel
Freezer, 1430lt (-22/-15) - UK Plug

ITEM # _____

MODEL # _____

NAME # _____

SIS # _____

AIA # _____



Electrolux



ecostore

2 Door Digital Stainless Steel Freezer,
1430lt (-22/-15) - UK Plug

727378 (RE4142FFG)

Eco Store Stainless Steel
Freezer - 1430 lt 2 Door
(-22/-15) UK Plug - 230
V/1N/50Hz

Short Form Specification

Item No. _____

Two full doors freezer with internal and external structure in 304 AISI stainless steel; galvanized steel external back, bottom and top panels. Digital control with cabinet temperature display and setting and manual activation of defrost cycle. Fully compliant HACCP digital controls include visible alarms. Optimized back to front forced air flow provides even temperature distribution and fast cooling in any conditions. Fitted with 75 mm-thick cyclopentane insulating foam. Door features lock and door microswitch to switch off the fan when the door is opened. Hidden evaporator to guarantee higher storage capacity and less corrosion problems. Built-in refrigeration unit; ventilated operation; automatic defrost and evaporation of defrost water. For ambient temperatures up to 43 °C. CFC and HCFC free. R404a gas in refrigeration circuit. Supplied with n. 6x2/1GN Rilsan coated grids and n. 6 sets of 2 stainless steel grid runners. Mounted on wheels and equipped with UK plug. Prearranged to fit RS485 port to facilitate connection to a remote computer and integrated HACCP systems.

APPROVAL: _____

Main Features

- Two full doors.
- Digital control with cabinet temperature display and setting and manual activation of defrost cycle. Fully compliant HACCP digital controls include visible alarms.
- Large storage area suitable to contain 2/1 GN grids or shelves on anti-tilt runners.
- Optimized back to front forced air flow provide even temperature distribution and fast cooling in any conditions.
- Automatic defrost.
- Internal structure with numerous charging positions available to host grids, ensuring higher net capacity and a greater storage space.
- Adjustable temperature range from -15 °C to -22 °C to suit meat, fish and dairy storage requirements.
- Performance guaranteed at ambient temperatures of +43° C.
- Cabinet fitted with up to 75 mm thickness of cyclopentane insulation for best insulating performance with 100% environmental protection.
- Removable triple-chamber balloon magnetic gasket to improve insulation and reduce energy consumption.
- Automatic evaporation of the defrosting water by hot gas on the top for energy saving.
- 60 mm-thick insulation covering the evaporator can be easily removed with a single operation.
- Rilsan coated grids for improved protection.
- Hidden evaporator thus guaranteeing higher storage capacity and less corrosion problems.

Construction

- Interior base with corners, pressed from a single sheet.
- External back panel in galvanized steel.
- Stainless steel runners and supports easily disassembled.
- Anti-corrosion bottom avoids any damage that may be caused to the cabinet by aggressive detergents employed to clean the floors.
- Lockable door.
- Door switch stops the fan when door is opened to avoid cold air exiting the cell, thus saving energy.
- Refrigerant type: R404a.
- CFC and HCFC-free insulation.
- Doors are self-closing and can be fully opened up to 180°.
- Mounted on wheels.
- The rounded internal corners, the easily removable runners and grids allow for ease of cleaning and high hygiene standards.
- Delivered with UK plug.

Included Accessories

- 6 of 2/1GN grey rilsan grid with 2 runners PNC 881020
- 1 of Kit of 4 small swivelling wheels, 2 with PNC 881035 brake, diam 50 mm, not for remote models

Optional Accessories

- 2 stainless steel runners for refrigerated cabinets - (Marine) PNC 880242

2 Door Digital Stainless Steel Freezer, 1430lt (-22/-15) - UK Plug

ecostore



Electrolux

ecostore
2 Door Digital Stainless Steel
Freezer, 1430lt (-22/-15) - UK Plug

- Spacer for 670 lt and 1430 lt refrigerated cabinets PNC 880248
- Kit integrated HACCP for digital refrigerators (IR33) PNC 880252
- Kit to fit pastry trays (400x600mm) PNC 880333
- 6 swivelling wheels (2 with brake), diameter=50mm PNC 880340
- 1/1GN plastic container with false bottom PNC 880705
- 4 swivelling wheels (2 with brake) for refrigerators, diam 125 mm, NOT for Glass Door and remote models PNC 881002
- 2/1GN grey rilsan grid PNC 881004
- 2/1GN aisi 304 stainless steel grid PNC 881016
- 2/1GN 304 AISI stainless steel grid with 2 runners PNC 881018
- 2/1GN grey rilsan grid with 2 runners PNC 881020
- Set of 2 stainless steel runners for 670/1430lt refrigerators and freezers PNC 881021
- Pedal opening for 1430lt refrigerator PNC 881033
- 2/1GN pvc container with lid and 2 runners PNC 881039
- 2/1GN perforated shelf PNC 881042
- 1/1GN rilsan steel wire basket h=150mm PNC 881043
- 3 grey rilsan central grids for 1430lt (not for glass door) PNC 881044
- 2/1GN grey rilsan basket+2 runners h=150mm PNC 881047
- Printer for HACCP basic version refrigerator PNC 881457



ecostore
2 Door Digital Stainless Steel Freezer, 1430lt (-22/-15) - UK Plug

The company reserves the right to make modifications to the products without prior notice. All information correct at time of printing.

2014.06.23



Electrolux

ecostore 2 Door Digital Stainless Steel Freezer, 1430lt (-22/-15) - UK Plug

Front

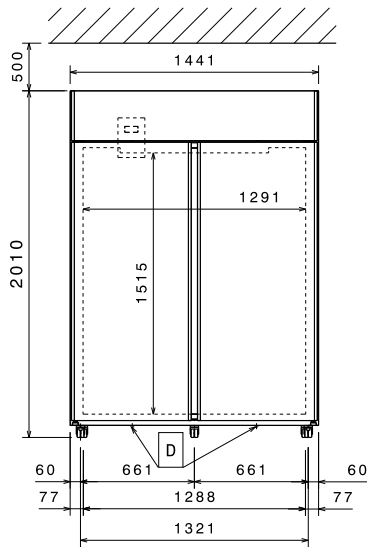

Top

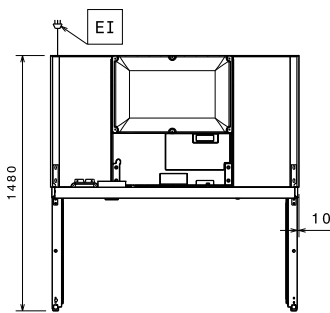

Side

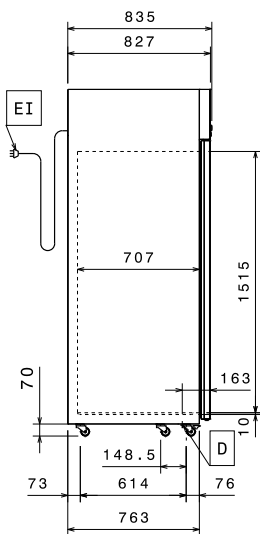

- ED = Remote electrical connection
- EI = Electrical connection
- RI = Refrigerant Inlet
- RO = Refrigerant Outlet

Electric

Supply voltage:	
727378 (RE4142FFG)	230 V/1 ph/50 Hz
Connected load:	0.935 kW

Key Information

Door hinges:	1 Left+1 Right
External dimensions, Height	2010 mm
External dimensions, Width	1441 mm
External dimensions, Depth	837 mm
External dimensions, Depth with Doors Open:	1480 mm
Number and type of doors:	2Full
Gross capacity	1430 lt
Number and type of grids (included):	6 - GN 2/1
Type of external material:	Stainless Steel
Type of internal material:	Stainless Steel
Internal panels material:	Stainless Steel
Number of positions & pitch:	44; 30 mm

Refrigeration Data

Control type:	Digital
Refrigerant type:	R404a
Refrigeration power:	965 W
Refrigeration power at evaporation temperature:	-30 °C
Refrigerant weight:	340 g
Operating temperature min.:	-22 °C
Operating temperature max.:	-15 °C
Operating mode	Ventilated



ecostore
2 Door Digital Stainless Steel Freezer, 1430lt (-22/-15) - UK Plug

The company reserves the right to make modifications to the products without prior notice. All information correct at time of printing.

2014.06.23