

BOLT

COFFEE GRINDER



USER MANUAL

COMPAK

BOLT

COFFEE GRINDER

1. SAFETY	4
2. DESCRIPTION	6
3. INSTRUCTIONS	6
4. IDENTIFICATION	7
5. TECHNICAL CHARACTERISTICS	7
6. EXTERNAL COMPONENTS	8
7. INSTALLATION	9
8. ADJUSTMENT	10
9. OPERATION	12
10. SETTINGS	14
11. CLEANING	24
12. MAINTENANCE	26
13. DECLARATION OF CONFORMITY	31

1. SAFETY

ADDITIONAL SAFETY MEASURES BUILT-IN TO OUR GRINDERS:

- **Special screw to keep the hopper fixed.**



This coffee grinder should only be used for the function for which it was designed: **grinding coffee beans.**



Do not use the grinder to grind other types of foods such as nuts or to grind finer granulated foods such as sugar and others.



This device **may be used by children aged 8 years and over, by people with reduced physical, sensory or mental capacities and by people without prior experience/knowledge,** provided they have received supervision or instructions on the safe use of the device and understand the associated risks.



Children should not play with the device.



Cleaning and maintenance of the device should not be carried out by children without supervision.



Do not allowing liquids to come into contact with internal or external surfaces

while the appliance is on or off, except for those parts expressly mentioned in the "CLEANING" section. If, for any reason, this happens, disconnect the power supply immediately and dry all surfaces carefully.

1. SAFETY

USERS SHOULD PAY SPECIAL ATTENTION TO, AND SCRUPULOUSLY OBEY THE FOLLOWING SAFETY INSTRUCTIONS



If it is necessary to access the interior, where the electrical components are located, **go to the nearest technical service**



In the event of any component breaking, or for any intervention we recommend contacting a technical services centre, who will carry out the repair or replacement, guaranteeing that safety standards are adhered to.



If the supplied cord is damaged, it must be replaced by the manufacturer, its service agent or similarly qualified persons in order to avoid a hazard.



Any other use will be considered improper and dangerous.



NOTE: The manufacturer will not be liable for damage caused either by the improper use of the device or by not following the stated safety measures.

2. DESCRIPTION



Your new grinder has been designed using the most sophisticated technologies in existence. **The result is a product of high quality that offers the assurance of the best results possible.** Our products are manufactured by hand, one by one, following the strictest quality requirements. In the manufacturing process, we use only the highest quality materials (aluminum, stainless steel, etc.) especially designated for being in contact with food stuff.

For the optimum functionality of the grinder models described in this user manual, the maximum work cycles are as follows:

Model	Work cycle	
	ON	OFF
BOLT 64	5 s	30 s
BOLT 83		

SOUND LEVEL

The level of sound emitted is:

Sound level	With coffee
BOLT 64	75,8 dB
BOLT 83	76 dB

3. INSTRUCTIONS



3.1. This manual is designed to provide the necessary information to correctly install, use and maintain the grinder, as well as to highlight precautions for users to keep in mind.

To ensure the best operation of the coffee grinder, please follow the instructions as outlined in this manual.



This manual should be saved for the life of the grinder, and should always be at the disposal of the operator.

3.2. This manual uses some special terms, such as:

- **Text in bold** to highlight the importance of some terms.
- **Numbers in parentheses after a word, which match the numbering of the items** in the image to the side or in the image of the external components.

Example: (1) - 1 Hopper Lid.

Icons:

Information	Warning
	

4. IDENTIFICATION



The technical characteristics plate is indelibly marked with the following information:

COMPAK **CE**

Made in Spain

MODEL		SERIAL NUMBER
DATE	ORDER	
ELECTRICAL DATA		
OPTIONS	OBSERVATIONS	

COMPAK Coffee Grinders s.a. Moli Barri, B. P.I. Can Barri 08-415 Bigues, Barcelona, Spain, IPX1 COFFEE GRINDER

i **NOTE:** The manufacturer reserves the right to change the machine components, according to the requirements of each market, and also for technological advances.

5. TECH. CHARACTERISTICS

5.1. SCOPE

The coffee grinders are intended for commercial applications where ground coffee must be used, or in small shops selling coffee, but not for continuous mass production of food.



This grinder should only be used to grind coffee beans.

Any other use is considered improper and dangerous.

i **NOTE:** The manufacturer is not liable for damage to persons, goods or the machine itself, if the safety regulations given in this manual are not followed, or the machine is used incorrectly.

5.2. TECHNICAL DATA

	100 V 50 Hz	100 V 60 Hz	110 V 60 Hz	220 V 60 Hz	230 V 50 Hz	240 V 50 Hz	
Electrical Power	600	600	700	730	630	650	W
Rotational velocity	1.270	1.530	1.580	1.500	1.290	1.310	rpm

	Ø Flat Burrs		Production 50 Hz*	Production 60 Hz*	Time for one dose (7g) 50Hz
BOLT 64	64	2.5	3,3	3,8	2,1
BOLT 83	83	3.3	5,8	6,9	1,2
	mm	in	g/s	g/s	s

	Time for one dose (7 gr) 60Hz	Hopper capacity		Net weight		Height Width Depth	
BOLT 64	1,8	1,250	3.08	16,69	36,80	660	25,98
BOLT 83	1,01			17,01	37,50	231	9,09
	s	Kg	lb	Kg	lb	mm	in

* Production based on a medium roast coffee and Espresso grinding point.

6. EXTERNAL COMPONENTS

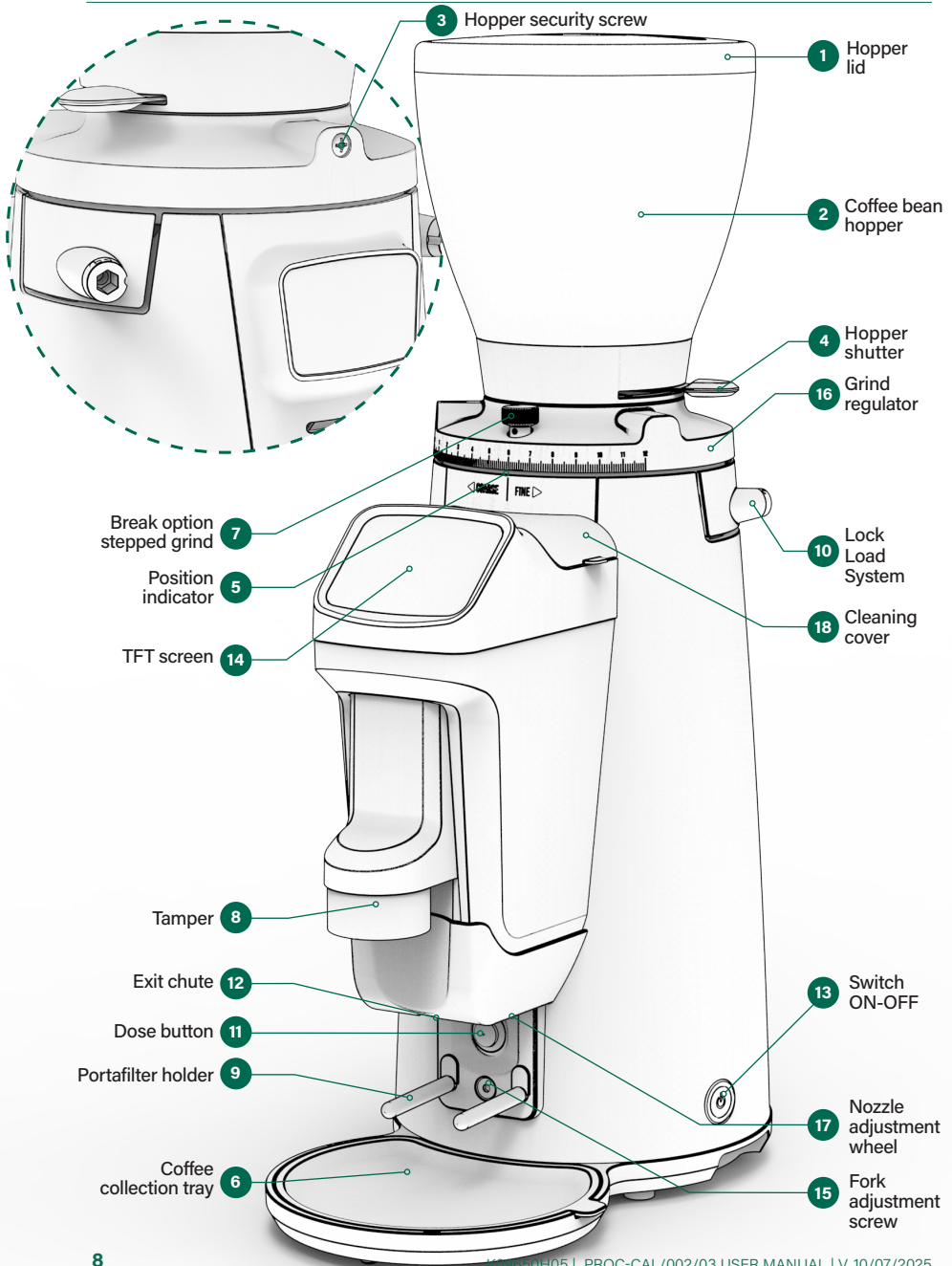

7. INSTALLATION

7.1. LEGAL NOTICES

 The installer must read this instruction manual carefully before installing the machine.



The installation of the device must be carried out by qualified and authorised personnel, obeying all the current safety and hygiene regulations.

7.2. IMPORTANT WARNINGS

 The operator must be a responsible adult. Never a child nor someone without the ability to accept that responsibility.

When handling the grinder, the following precautions should be obeyed:

- When removing the grinder from the packaging, always pull it by the handles of the bag.
- Feet must not be bare.
- Hands and feet must be dry.
- Do not get the machine wet.
- Do not expose the machine to direct sunlight or other atmospheric agents.
- Never insert any object into the coffee inlet or outlet while the appliance is running. (Please remember that when the grinder stops, the burrs will keep turning for a short while).
- When unplugging the grinder, always pull on the plug and never the power cable to avoid a possible short circuit.
- Care is needed when handling cutting burrs during cleaning.

 **NOTE:** This coffee grinder should not be installed in places (SUCH AS INDUSTRIAL KITCHENS) where are expected to be cleaned using water jets or a steam cleaner.

7.3. WHERE TO USE IT

 The appliance must be installed on a solid and flat surface.



The minimum size for the working space, to ensure you get the best performance from the machine, must be the following:

Height	680 26.77	mm in
Width	251 9.88	mm in
Depth	404 15.90	mm in

- Install the grinders on tables that are completely level and in areas free from external vibrations
- Install the grinders in areas where there are installations with a ground connection.
- Avoid places where abrupt changes in temperature, humidity or airflow may occur.

7.4. INSTALLING THE COFFEE GRINDER

Before connecting the coffee grinder, check the following:

- The characteristics on the data plate must match those of the electrical mains network.
- The electrical connection plug matches the socket into which it is to be plugged.
- Ensure that the electrical power of the facility is adequate for the power consumed by the appliance.
- The point of connection to the electrical mains network must be protected with the appropriate electrical protection device.
- The equipment must be correctly connected to a ground connection according to the current safety regulations.

8. ADJUSTMENT

8.1. GRINDER SET UP

Place the hopper (2) on the grind regulator (16) and make sure the bean trap (4) is in the closed position (Fig. 1).

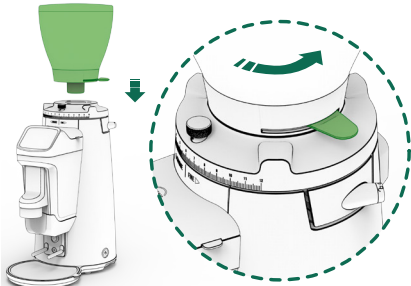

Fig. 1

Remove the hopper lid (1), fill the hopper with coffee (2), and replace the lid on the hopper (1) (Fig. 3).



Fig. 3

Lock the hopper (2) in place using a phillips head screw driver to gently tighten the hopper security screw making it match to the hole at the bean hopper collar (3) (Fig. 2).



Fig. 2

Plug in the grinder, and press the main power switch (13) to **ON** position, and open the bean trap (4) to allow coffee to pass into the grind chamber (Fig. 4).

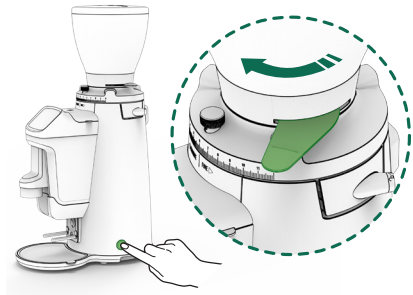

Fig. 4

8. ADJUSTMENT

8.2. ADJUSTING THE PORTAFILTER SUPPORT

In order to ensure the proper distribution of ground coffee in the portafilter, it is possible to adjust the height of the lower portafilter support (9) and move the nozzle back and forth using the wheel to adjust it (17).

To do this adjustment operation the height:

1. Loosen the screw (15) by using the Allen Key #4 included with your grinder.
2. Adjust the support (9) to the desired height using the portafilter as the point of reference.
3. Tighten the screw (15) with the Allen Key #4 provided (Fig. 5).

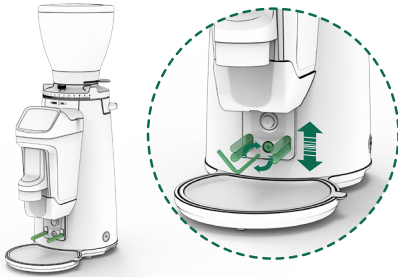

Fig. 5

4. To move the nozzle forth turn the wheel (17) clockwise, and back counterclockwise (Fig. 6).

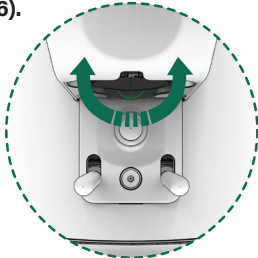

Fig. 6

8.3. GRIND ADJUSTMENT SYSTEM

Rotate the grind regulator (16) until reaching the grind level desired.

Rotating the grind regulator clockwise will result in a coarser grind; turning the regulator counterclockwise will result in a finer grinder (Fig. 7).

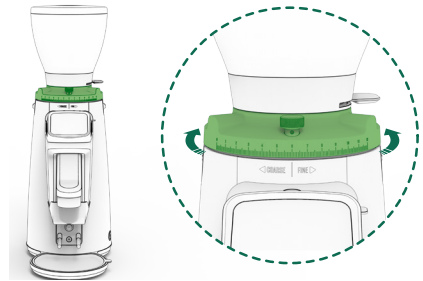

Fig. 7

Once you reach the desired grinding point (16), you can fix the grinding regulation using the regulation break (7) (Fig. 8).

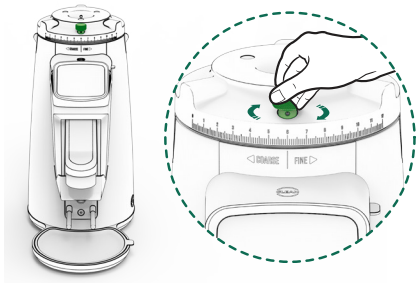

Fig. 8

8. ADJUSTMENT

NOTE: It is recommended that this operation be performed, when changing to a finer grinding, with the motor running, to prevent coffee from building up between the burrs and blocking the grinder.

NOTE: If the coffee throughput is very low, this is because the coffee is being ground very fine. If the throughput is very high, this is because the coffee is being ground very coarse. A perfect Espresso is produced when the grinding gives an infusion of 25 ml of coffee in 25 seconds using about 7 g of ground coffee.

8.4. PREPARATION OF THE PORTAFILTER DETECTOR (OPTIONAL)

1. Place the detector on the double portafilter (Fig. 1).
2. Check that the detector ring tab is properly closed (Fig. 2).
3. Make sure that the arrow is in the correct position on the lower side (Fig. 3).

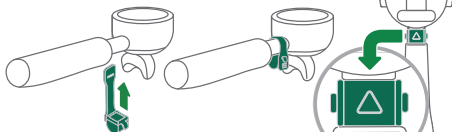

Fig. 1

Fig. 2

Fig. 3

9. OPERATION

9.1. MAIN SWITCH

The main switch (13) has the following positions: **OFF/ON** (Fig. 4)

	BOLT
The equipment's electronic functions are activated	ON
Equipment off	OFF



Fig. 4

9.2. UTILIZATION

Through the program menu (section 10.4.3), it is possible to select three distinct functional modes: **PUSH**, **DETECTION** and **TOUCH**.

9.3. PUSH MODE

In the **PUSH** mode, a pre-programmed single, double or triple* dose can be set by simple pressing the corresponding icon on the TFT screen (14).

The preselection of a single, double or triple* dose will remain active until it is changed by pressing one of the three numbered icons. This preselection is reflected on the TFT screen (14) with the icon of the active selection in the secondary color, and the rest of the icons in the principle color.

Dispensing the preselected dose by pressing the lower pulse button (11) one time. When the grinding cycle begins, a timer countdown will begin on the TFT screen (14), which will count down the timed dose cycle to zero.

*Triple dose only can be activated on FRESH MODE

9. OPERATION

On FRESH MODE once the grind cycle is initiated, it can be paused by pressing the lower activation button (11). The cycle will pause, and will complete the timed grind cycle as long as the lower activation button is pressed again within 10 seconds. After 10 seconds of inactivity, the grind cycle will reset to the complete cycle time.

Grind pause can be activated or deactivated by pressing the lower pulse button (11). First, set up by following these steps: **MENU / SETTINGS / GRIND PAUSE.**

9.4. TOUCH MODE

In this mode of operation when making the selection of single, double or triple* doses of coffee by pressing the appropriate numeric TFT icon screen (14) starts grinding the selected dosis without the need to actuate the lower dose button (11).

The time set for that dose will decrease to zero, at which point the dose ends.

On FRESH MODE once the cycle starts grinding using the lower dose button (11) and is pressed again, the grinding cycle will stop. If within 10 seconds it is pressed again, it will complete the remaining time of the original dose time setting. After 10 seconds of inactivity the grinder will return to standby mode.

To pause by pressing the lower activation button (11), you can enable or disable, accessing **MENU / SETTINGS / GRIND PAUSE.**

On FRESH MODE, pause grinding may also be performed by pressing the active icon on the TFT display (14). This pause cannot be enabled or disabled via the **MENU.**

9.5. DETECTION MODE

In this operating mode, the grinder detects the presence of the portafilter through the movement of a fitted Tag. When the portafilter with the mounted Tag comes in range, the system identifies it and automatically grinds DOSE 2 by pressing the lower portafilter button (11) once.

Once Dose 2 is detected, you have 5 seconds to press the lower button (11). If you want to cancel the selection, you can press 1 on the TFT screen (14). If after 5 seconds, the lower button is not pressed (11), the grinder will return to the standby mode.

9.6. TAMPER

9.6.1. Fixed Tamper (Optional)

Position the portafilter below the tamper and push up to tamp the ground coffee (Fig. 5).

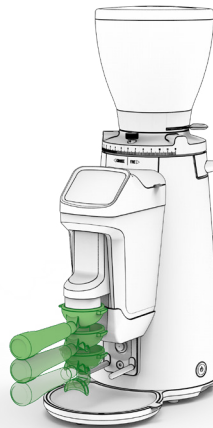
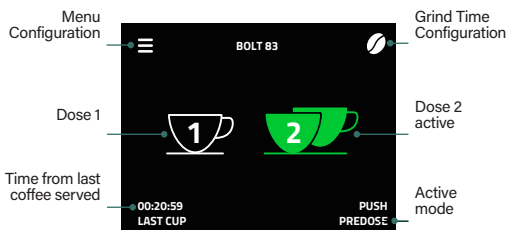

Fig. 5

10. SETTINGS

10.1. DISPLAY ICON GUIDE

DISPLAY PREDOSE MODE 2 DOSE



DISPLAY PREDOSE MODE SINGLE DOSE

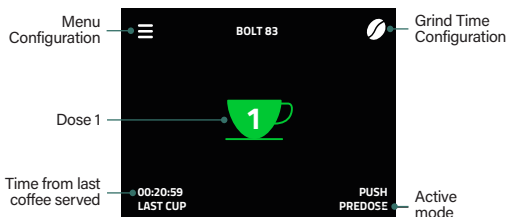

DISPLAY FRESH MODE

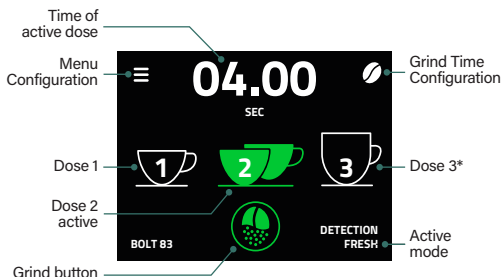

* In the case of 3 dose activation

10.2. GRIND TIME CONFIGURATIONS

10.2.1. The grinding times can be configured for automatic, preselection and instantaneous operation modes, and when modified in one of the three modes they are updated for all modes simultaneously.

To modify 1 dose, push the Coffee Bean icon  of the Home menu and the dose time menu will be accessed.

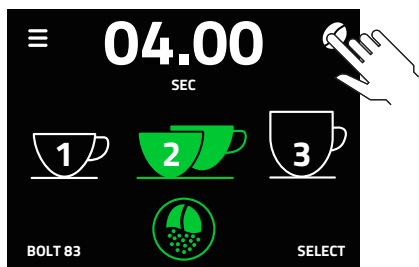

10.2.2. Within the dose time menu you can choose to change the time of 1, 2 or 3 doses (if it is active), by pressing the symbol > that is in each of them, thus going to the dose time configuration menu. To access dose 3 you must scroll down so that the option appears.

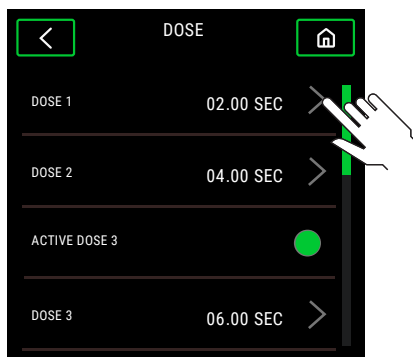

10. SETTINGS

10.2.3. Within the dose time configuration menu, it can be changed in different ways depending on the grinder's operating mode: **Predose** or **Fresh**. In Predose mode, this is done by sliding the seconds and tenths of a second up or down until the desired time is reached. To save the configured dose, press **OK**.

In **Fresh** mode, it is also possible to modify the grinding time for each dose using the Portafilter. To do this, press and hold the dosing button () until the desired coffee time or quantity is reached. To save the configured dose, press **OK**.

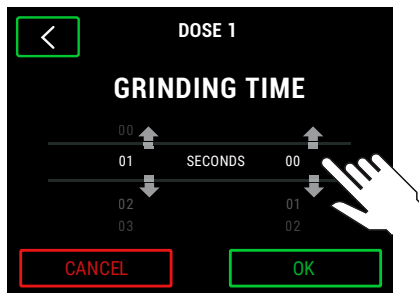

10.2.4. When accepting, it will return to the previous menu to be able to continue changing more dose times or if the button  is pressed it will return to the Home screen.

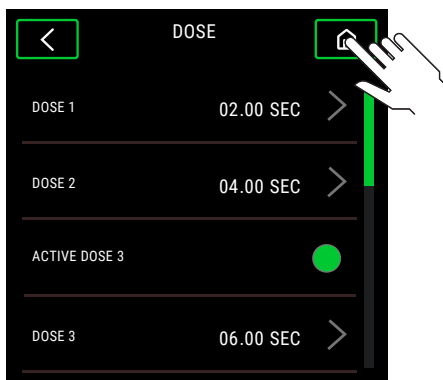

10.3. ACCESS TO THE CONFIGURATION MENU

10.3.1. Press 

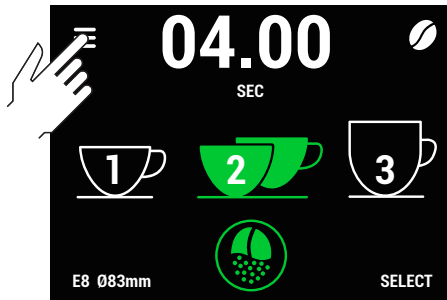

10.3.2. There are 5 options, use the horizontal scroll to navigate between: **Mode**, **Cleaning**, **Statistics**, **Dose Settings** and **Settings**.

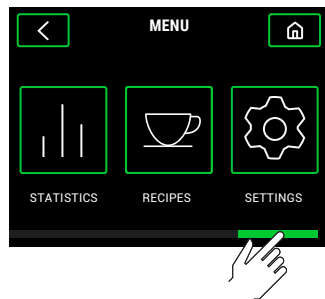
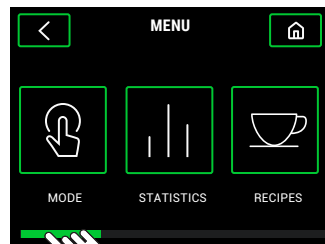

10. SETTINGS

10.4. MODE

10.4.1. Press  in the configuration Menu

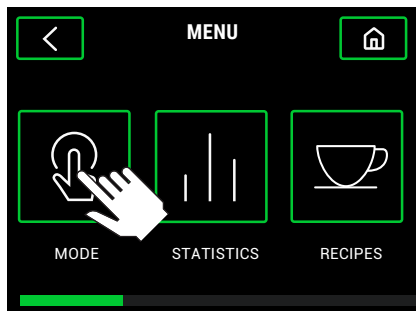

10.4.2 There are two different options to operate the grinder, **Predose** where the doses are pre-grind before you ask for them or **Fresh** where are grinded by demand.

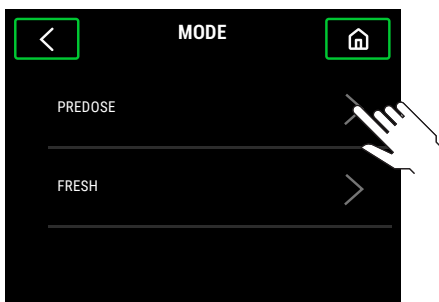

By pressing the symbol  in one of them you will access to the next menu where you will be able to chose between the different working modes.

10.4.3 Choose between the different working modes: **Push**, **Detection** or **Touch**.

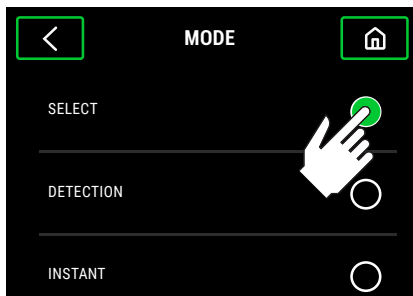

10.5. CLEANING

10.5.1. Press  in the configuration menu to activate the **Cleaning Mode**.

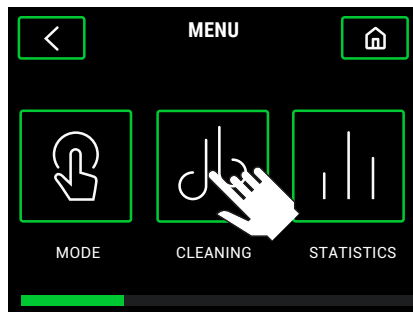

In that mode the grinder opens the gates and is possible to clean using a circular brush opening the Cleaning cover  from the top.

10. SETTINGS

The screen will display the message “Doors open, please clean with brush from the top” and will remain in that state until you press the **OK** to go back to working mode.

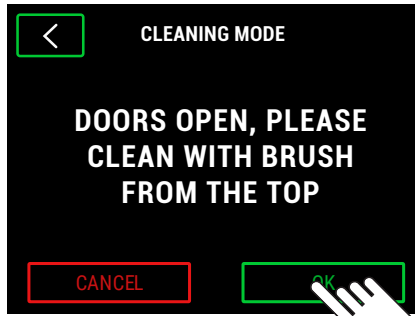

10.6. STATISTICS

10.6.1. Press 

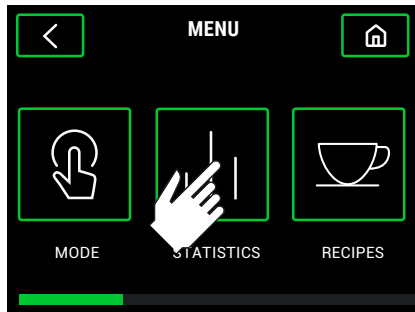

10.6.2. The number of independent doses for each selection is shown, either absolute from the date of installation of the grinder, or relative from a counter reset date. Burrs wear can also be checked.



10.6.3. Relative Statistics can be reset by pressing the Reset Relative button and then entering the Password.

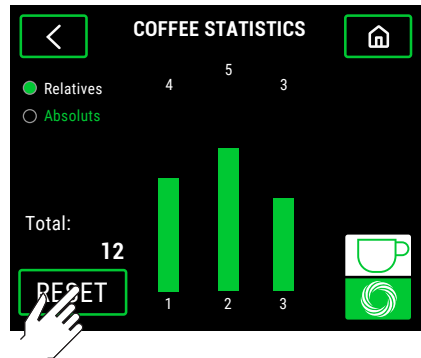

10. SETTINGS

10.6.4. To access the Burrs wear graph, press

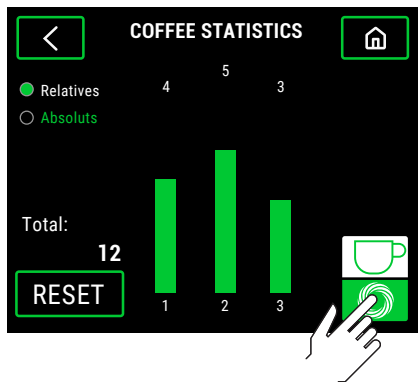

10.6.5. There is a graphical view of the Burrs wear in % as well as the Total ground Kg and the Kg configured for the Burrs change notice.

Model	KG
BOLT 64	1000
BOLT 83	1200

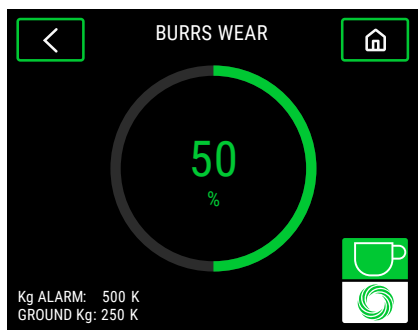

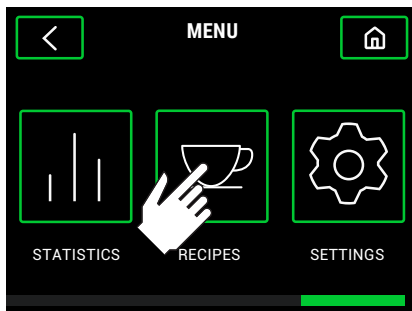

10.7. DOSE SETTINGS

10.7.1. Press

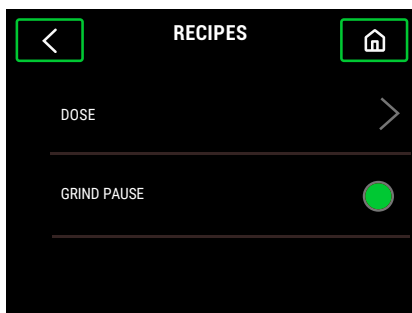

10.7.2 There are two options, the first one will access the menu to configure the dose times, the second, activate or deactivate the Grinding Pause (by default it is active).



If you access the menu to configure dose times, we can follow the steps in point **10.2.2** to configure the dose time. In the Fresh mode you'll be able to activate or deactivate the grinding pause, press the button , if the grinding pause is active, or  if it is deactivated.

10. SETTINGS

10.8. SETTINGS

10.8.1. Press  in the configuration menu

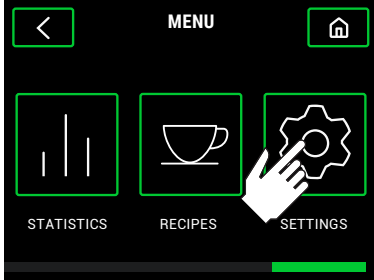

There are 7 Settings options. Use the horizontal scroll to navigate between: **Password, Language, Screensaver, Date / Hour, Sounds, Dose Alarm and Cleaning Alarm.**

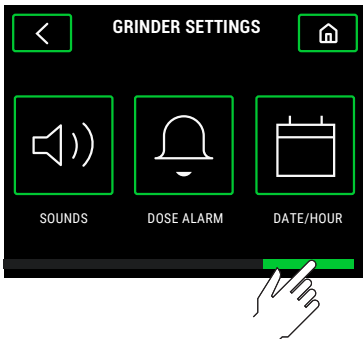
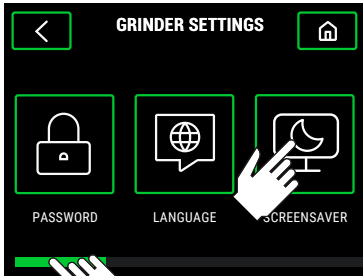

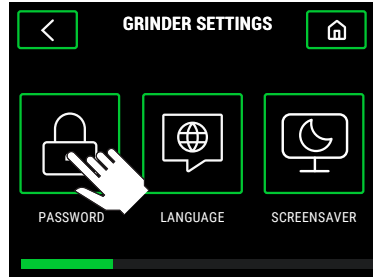

10.9. PASSWORD

10.9.1. Press 



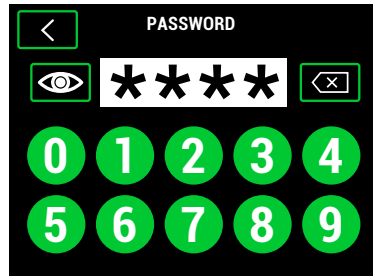

If the Password is active, enter the Default one: 0000

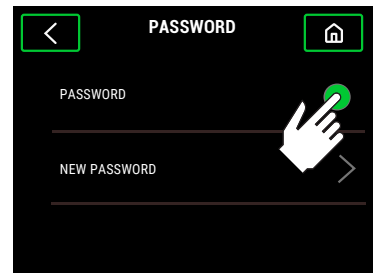

10.9.2. Activate or deactivate the Password by pressing . To modify the Password press >



10. SETTINGS

10.9.3. Enter a new 4 numbers Password. Show or hide the numbers by pressing  or delete the numbers pressing .

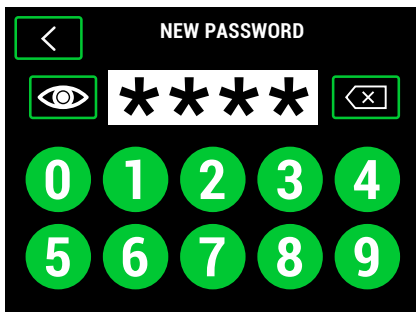

10.10. LANGUAGE

10.10.1. Press .

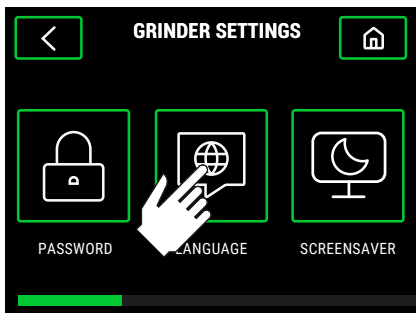

10.10.2. Choose between the different languages available using the vertical scroll.

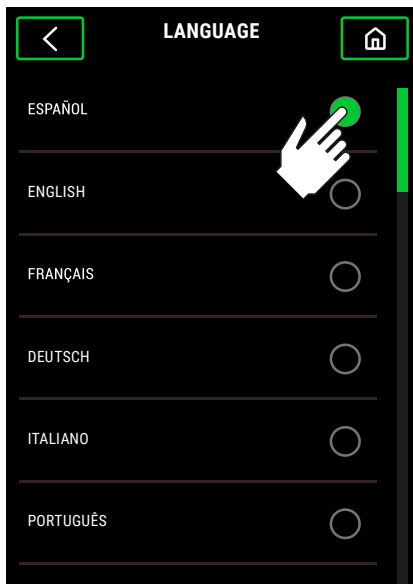

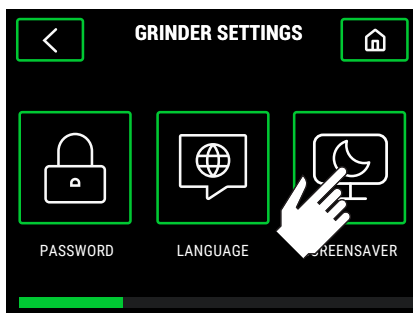

10.11. SCREENSAVER

10.11.1. Press .



10. SETTINGS

10.11.2. Activate or deactivate the Screensaver by pressing . To modify the activation time press 

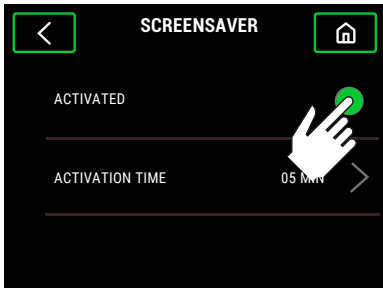

10.11.3. Change the minutes by sliding up or down and press the button **OK** to confirm.

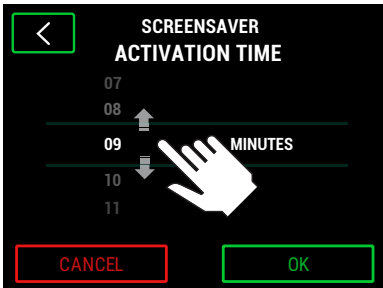

10.12. SOUNDS

10.12.1. Press 

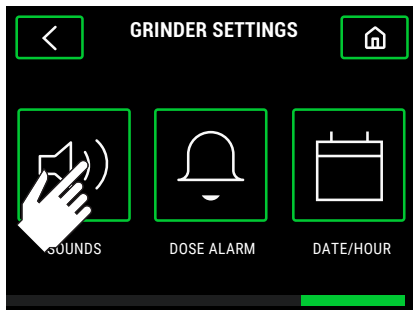

10.12.2. Activate or deactivate the sound by pressing the button 

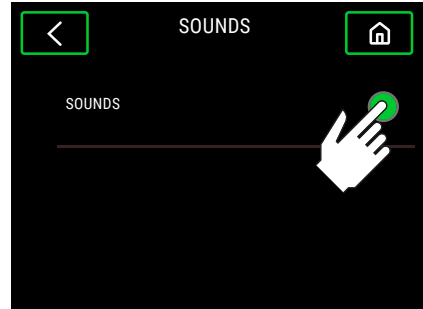

10.13. BURRS CHANGE ALARM

10.13.1. Press 

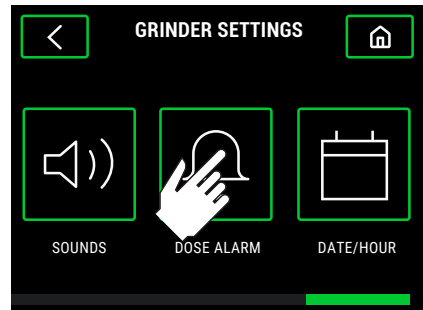

10.13.2. Choose between, activate or deactivate the Burrs change alarm, adjust the Weight of the Dose 2, adjust the Burrs change alarm Kg or by using the vertical scroll, Rest Alarm.

10. SETTINGS

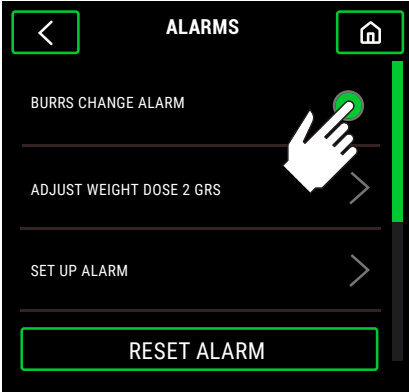

10.13.3. To adjust the Weight of Dose 2 press >

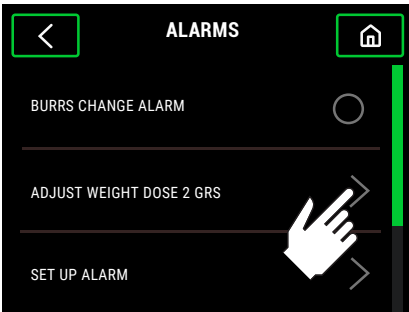

10.13.4. Change the grams of Dose 2 by sliding the grams or tenths of a gram up or down until the desired weight is reached and press **OK** the button to accept.

Dose 2 will be the average weight used to determine burr wear.

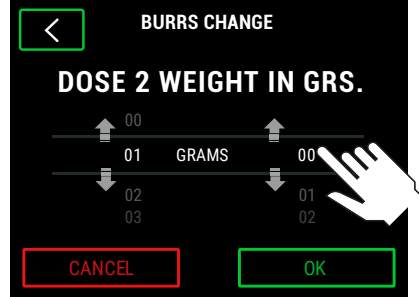

10.13.5. To delete the stored data of the Burr change alarm, i.e. once replaced the current set of Burrs, scroll vertically, press the Reset Alarm button and then enter the Password.

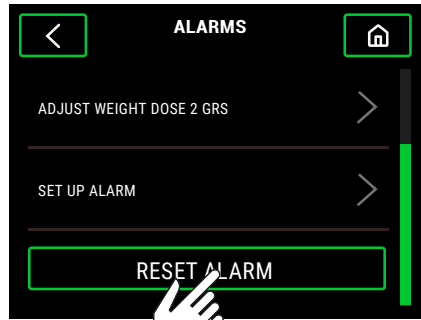

10. SETTINGS

10.14. DATE/HOUR

10.14.1. Press 

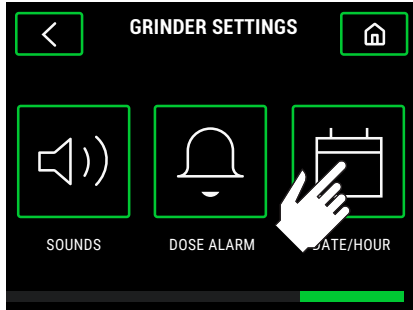

10.14.2. Edit both the time, the date or the way to show the date between DD/MM/YY or MM/DD/YY.

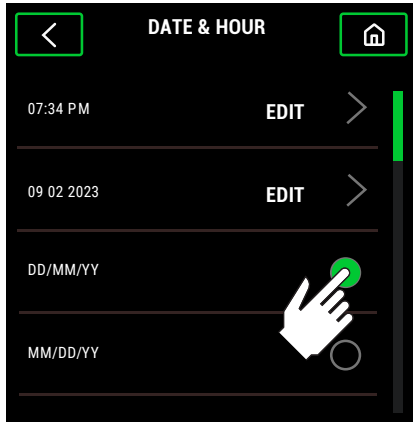

10.14.3. Edit the time by pressing > to access the time setting screen. Change the hours, minutes and seconds by sliding up or down until the desired time is obtained and press the button **OK** to confirm.

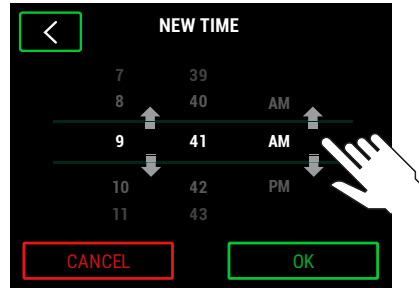

10.14.4. Edit the date by pressing > to access the date setting screen. change the days, months and years by sliding up or down until the desired time is obtained and press the button **OK** to confirm.

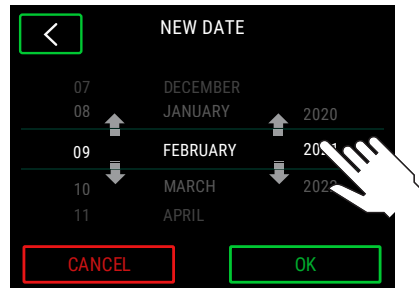

10.15. CLEANING ALARM

10.15.1. Press 

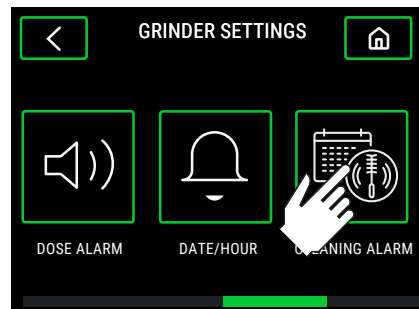

10. SETTINGS

11. CLEANING

10.15.2. Activate or deactivate the Cleaning Alarm by pressing . To modify the quantity of KG press >

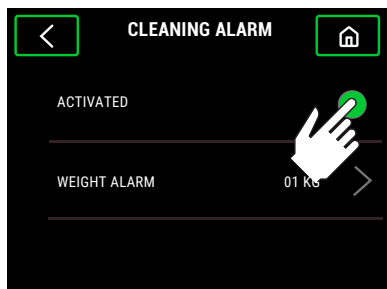

10.15.3. Change the KG by sliding up or down and press the button **OK** to confirm.

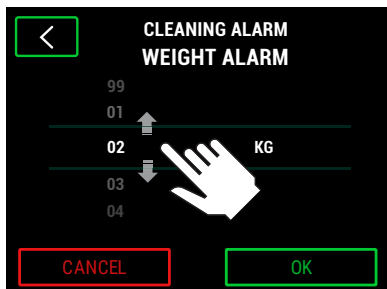

10.15.4. After grinding the specified amount of KG, an alarm will remind you to clean the coffee exit chute. The alarm will remain until you complete the instructions describe in **11.3.**

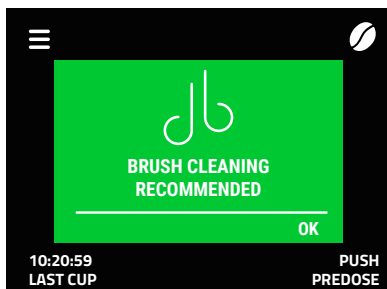

11.1. GENERAL CLEANING

11.1.1. To ensure that the grinder functions properly, and produces the highest quality grind possible, the parts that come into contact with coffee should be cleaned periodically.

General Cleaning guidelines as follows:

- Always turn the main power switch to the off position (13).
- Unplug the machine from the power source.
- Do not submerge the grinder in water or use power washing devices.
- The appliance is not to be cleaned with a water jet or steam cleaner.

11.2. BEAN HOPPER CLEANING

11.2.1. In order to properly clean the bean hopper (2), first empty out all remaining beans and fragments.

To remove the hopper, first close the bean trap (4), and then loosen the hopper lock screw (3) and lift the hopper straight up.

Clean the hopper (2) with a moist soft cloth or with a small amount of water and neutral soap to eliminate any oily residue from the beans.

Replace the bean hopper (2) following the same steps as the removal process, but in reverse.

11.3. CLEANING THE COFFEE EXIT CHUTE

11.3.1. It is very important to maintain the exit chute clean of coffee in order to ensure the consistency of the dosis and the continued functioning of the grinder.

11. CLEANING

11.3.2. Press  in the configuration menu to activate the Cleaning Mode.

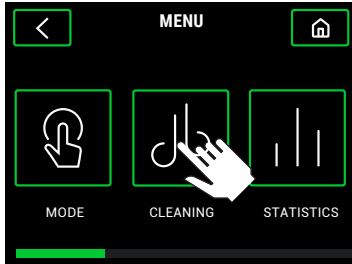

11.3.3. The screen will display the message "Doors will open and coffee will fall. Be careful!". Once you press OK the grinder opens the gates and a double dose falls.

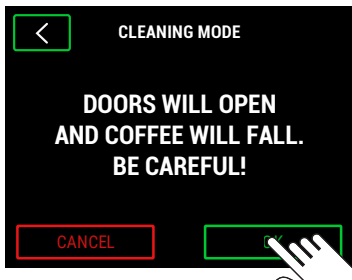

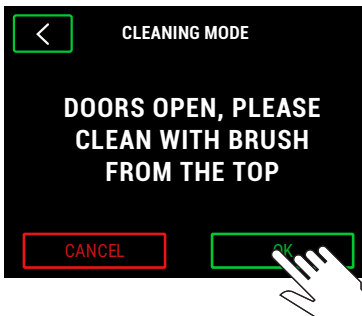

11.3.4. The screen will display the message "Doors open, please clean with brush from the top" and will remain in that state until you press the OK to go back to working mode.

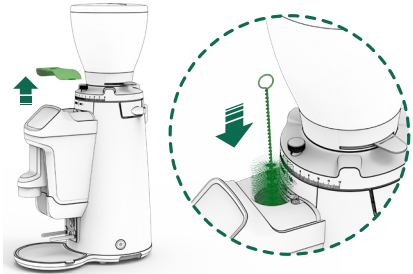

11.3.5. Open the Cleaning cover  to have access to the top of the chute, and clean it with a circular brush.







The dosis button  along with the and lower portafilter holders  should be wiped periodically to prevent build up of coffee grounds and oils.

11.4. CLEANING THE GRIND CHAMBER

11.4.1. It is recommended that the grind chamber be cleaned monthly with a cleaner. This process will eliminate smelly residues from the coffee remains, which can negatively affect the quality of the brewed coffee.

Care is needed when handling cutting burrs during cleaning.

The steps to follow are:

- In order to properly clean the bean hopper , first empty out all remaining beans and fragments.
- Close the bean trap on the hopper  and grind out the remaining coffee in the grind chamber.
- Pour the recommended grinder cleaning product into the bean hopper  and open the bean trap , allowing the cleaning product to pass into the grind chamber.

11. CLEANING

- Grind the cleaning product at a medium coarse grind setting until the recommended amount is passed through the system and nothing remains in the grind chamber.
- Clean the hopper (2) and refill with coffee beans.
- Discard the first 2-3 doses of coffee to assure that the residual cleaning product is removed from the grind chamber and set the grind regulator to the desired setting (16).
- Following these steps will ensure that the grinder is clean and ready for use.
- We do not recommend the taking apart of the grind assembly unless changing burrs, or removing a blockage/obstruction in the grind chamber. Removal of the grind assembly should be performed by a qualified service technician.

11.5. CLEANING THE OUTSIDE OF THE GRINDER

11.5.1. To clean the exterior of the grinder, first wipe with a dry soft cloth, and then gently wipe with a damp cloth and neutral soap.

11.6. CLEANING THE TOUCH SCREEN

11.6.1. Proper cleaning should be done with a soft, damp microfiber towel. Preferably distilled water or other cleaning product specifically designed for touch screen cleaning.

Turn off the grinder and gently wipe off the screen using a circular motion.

12. MAINTENANCE

12.1. GENERAL WARNING

12.1.1. Before performing any type of maintenance you should:

- Always turn **OFF** the main power switch to the off position (13).
- If the grinder is jammed, unplug it from the power source and contact an authorized service technician.

In case of breakdown or malfunction, turn off the appliance, we should never try to repair it, it is essential to call the nearest technical service.

⚠ NOTE: Not following these warnings can compromise the safety of the grinder as well as the user.

12.2. GENERAL MAINTENANCE OF THE GRIND CHAMBER

12.2.1. To guarantee the efficiency and correct operation of the grinder, it is essential to follow manufacturer instructions and ensure that all maintenance work is carried out by qualified staff.

Dull burrs will result in; a lower quality grind, greater heat generation in the coffee and grinder, increased electrical consumption, and finally it puts additional stress on the grinder motor.

⚠ Not following the recommended burr life guidelines can compromise the safety of the grinder.

These operation should be done by a qualified service technician wearing safety gloves.

12. MAINTENANCE

12.3. GRINDING GROUP MAINTENANCE

To perform grind chamber maintenance please observe the following steps:

12.3.1. Turn off the grinder by making sure the main power switch (13) is on the **OFF** position. Disconnect the plug from the power source. Loosen the hopper security screw (3) using a Phillips head screw driver as seen in (Fig. 1).

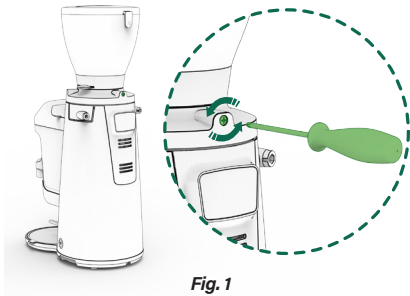

12.3.2. Check that the shutter is in the closed position before removing the hopper from the grind regulator (7) (Fig. 2).

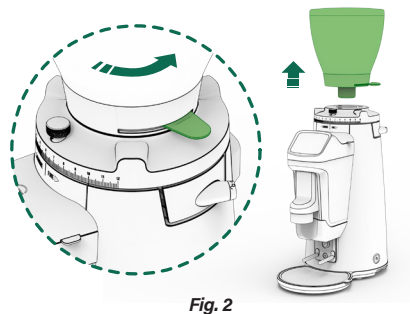

12.3.3. From that point, if your grinder have "Lock Load System" skip until the point 12.3.7. if not, keep following the next the steps. To avoid losing the position of the regulator scale with respect to the current grinding point, it is essential to tighten the setting of the grinding regulator using the adjusting brake (7) by turning it clockwise (Fig. 3). Remove the screw with a Hex Allen screwdriver #2 located in the adjusting brake (7). (Fig. 4).

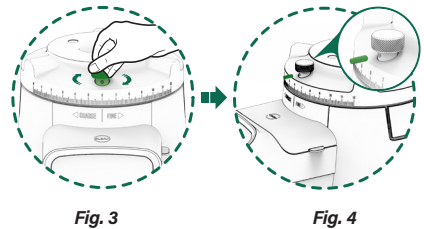

12.3.4. Remove the regulation brake by pulling upwards (7) (Fig. 5). Loosen the grinding regulator screws using an Hex Allen screwdriver #3, according to (Fig. 6).

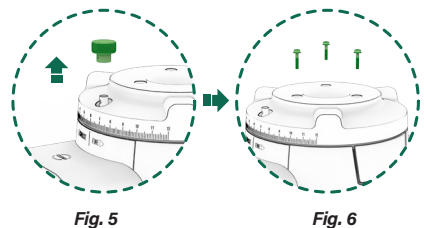

12. MAINTENANCE

12.3.5. Remove the regulator by pulling upwards (**Fig. 7**). Loosen the upper burs support screws with a Hex Allen screwdriver #3, according to (**Fig. 8**).

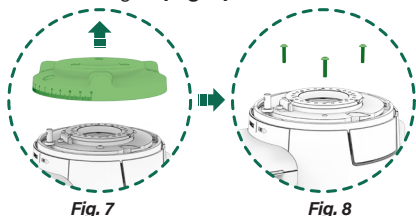

12.3.6. Remove the upper holder by pulling upwards to access the grinding cavity, clean the interior with the help of a brush or vacuum cleaner and remove any coffee residue from the grinding cavity (**Fig. 9**).

When reassembling, keep going by reversing the steps and pay attention to align the regulator hole to the cylinder of the regulation brake according to (**Fig. 10**).

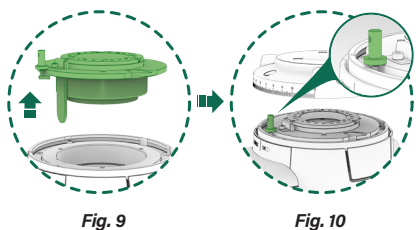

Only for grinders with a Lock Load System

12.3.7. To avoid losing the position of the regulator scale with respect to the current grinding point, it is essential to tighten the setting of the grinding regulator using the adjusting brake by turning it clockwise (**Fig. 11**).

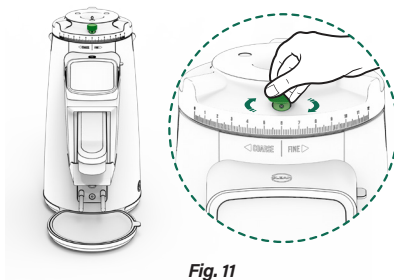

12.3.8. To access the grinding cavity, insert a #8 Hex Allen Key into the hexagonal holes located on the **Lock Load System** (40) according to (**Fig. 12**). Turn it in the direction shown by the icons or according to (**Fig. 13**).

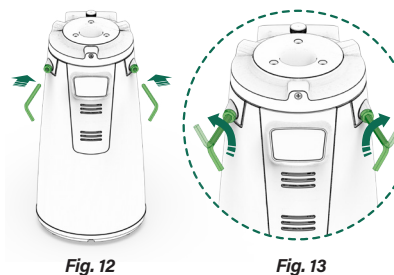

12.3.9. Pull up holding the grind regulator (13), to access the grinding cavity, clean the interior with the help of a brush or vacuum cleaner and remove any coffee residue from the grinding cavity (**Fig. 14**).

12. MAINTENANCE

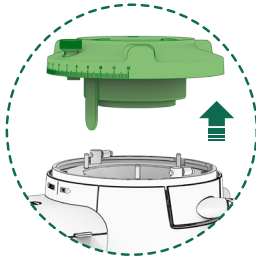

Fig. 14

12.3.10. When reassembling the grind regulator, face the silicone curtain in front and the three holes with three pins in the grind chamber (Fig. 15).

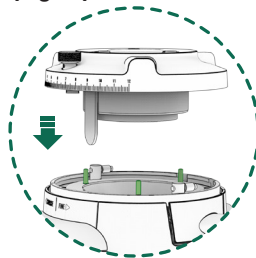

Fig. 15

12.3.11. When the grinding regulator is in place, lock the system by using a #8 Hex Allen Key into the hexagonal holes (40) and turning it in the direction shown by the icons and according to (Fig. 16) until it is in the working position.

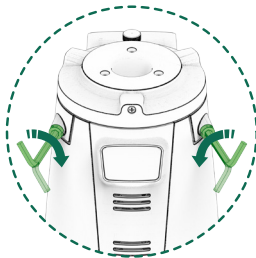

Fig. 16

12.4. REPLACING THE SILICONE CURTAIN

The silicon curtain, located inside the coffee spout, ensures dose regularity and reduces static electricity. It can be replaced after removing the regulator from the grinder (Fig. 13) Remove the screw with a Hex Allen screwdriver #2 located in the adjusting brake (7) (Fig. 17). Remove the regulation brake by pulling upwards and downwards (7) (Fig. 18).

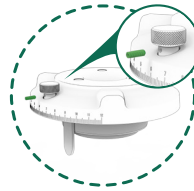

Fig. 17

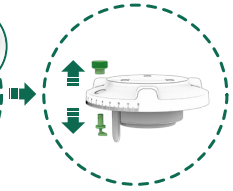

Fig. 18

Loosen the grinding regulator screws using an Hex Allen screwdriver #3, according to (Fig. 19). Remove the regulator by pulling upwards (Fig. 20).

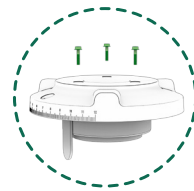

Fig. 19

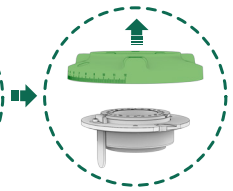

Fig. 20

12. MAINTENANCE

Loosen screw with #3 Allen key, remove curtain support, replace silicone curtain with new or different hardness to meet coffee's needs. **(Fig. 21).**

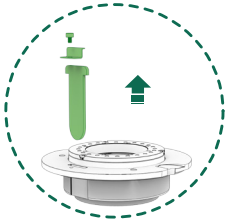

Fig. 21

13. DECLARATION OF CONFORMITY

In accordance with European community directives, quality certificates have been applied. All materials have been adapted and technical reports are available at our offices.

2014/30/UE on the approximation of the laws of the Member States relating to electromagnetic compatibility.

06/42/EC amending Directive 95/16/EC on the approximation of the laws of the Member States relating to machinery

REG. 1935/2004 amending Directive 89/109/EC on the approximation of the laws of the Member States relating to material and objects destined to make contact with nutritional products.

03/108/EC amending Directive 2002/96/EC on waste electrical and electronic equipment (WEEE).

2014/34/UE on the harmonization of the laws of Member States relating to electrical equipment designed for use within certain voltage limits.

2012/19/UE of 04/07/2012 on the approximation of the laws of the Member States on waste electrical and electronic equipment (WEEE).

11/65/EU related to the restriction on the usage of certain dangerous substances with electrical equipment and electronics.

Environment

Do not throw the appliance away with the normal household waste; hand it in at an official recycling collection point. By doing this, you will help to preserve the environment.

The Legal Representative

Jesús Ascaso



Compak Coffee Grinders, s.a.

Molí Barri, Parcela B - Pol. Ind. Can Barri - 08415 Bigues i Riells - Barcelona - Spain
Ph. 34 93 703 13 00 - Fax 34 93 703 13 23 - compakgrinders.com - info@compak.es



K09650H05 | PROC-CAL/002/03 USER MANUAL | V.10/07/2025

