

Compact Gastronorm Prep Stations

With Glass Display

BPD2

Depth of polypropylene cutting board - 135mm

BPD3



Glass structure requires assembly on site.

FEATURES

High grade AISI 304 stainless steel exterior & interior

Internal corners rounded to aid cleaning

Self closing doors

1 x adjustable GN1/1 shelf per door

GN sized well accepts containers - max depth 150 mm (containers are not included)

Glass structure over containers with intermediate shelf to display non-refrigerated items

135mm deep polypropylene cutting board

Adjustable feet

Replaceable door gasket

35mm insulation

Easily removable condenser filter for cleaning

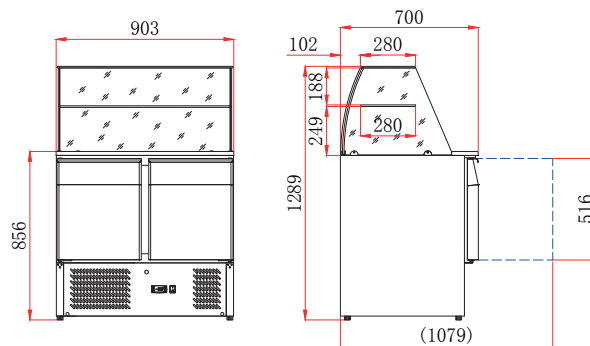

TECHNICAL SPECIFICATIONS

Controller: Dixell controller

Cooling: Fan assisted

Defrost: Automatic

Refrigerant: R600a (BPD2)
R290 (BPD3)

Climate Class: 4

Temperature Range: +2°C ~ +8°C

Decibels: 42dBA

Power Supply: 13amp

MODEL	DOOR	CONTAINER CAPACITY	GROSS CAPACITY	EXT. DIMENSIONS (H x W x D mm)	POWER CONSUMPTION	WEIGHT (kg)	RRP
BPD2	2	2 x GN1/1 + 3 x GN1/6	240L	1289 x 903 x 700	170W	123	
BPD3	3	4 x GN1/1	368L	1289 x 1368 x 700	240W	164	



See page 336 for full GN container range

