



VEGETABLE PREPARATION MACHINE CA-401 VV (VARIABLE SPEED)

Commercial vegetable preparation machine with an hourly output of up to 650 Kg.



DYNAMIC PREPARATION
COMMERCIAL VEGETABLE PREPARATION MACHINES

SALES DESCRIPTION

Variable speed motor block and a universal attachment.

FEATURES AND BENEFITS

- ✓ Electronic, user-friendly control board with 5 speeds.
- ✓ Stainless steel construction and highest quality material, all suitable for contact with food.
- ✓ New production technology that gives a uniform, highest-quality cutting result.
- ✓ Ergonomic design: product is sliced/cut/shredded in one single movement.
- ✓ The large range of high quality discs and grids allows the operator to obtain over 70 different styles of product.
- ✓ Lateral product ejection, which allows the appliance to be placed in a less deep working surface.
- ✓ This directs the product avoiding splashing.
- ✓ Electronic, user-friendly control board with 5 speeds.
- ✓ Easily removable lever and lid for cleaning purposes.
- ✓ NSF-International certified appliance (complying with Hygiene, Cleaning and Food Material regulations).

INCLUDES

- ✓ 1 speed motor block.
- ✓ Core drill (optional use).
- ✓ Large capacity hopper.

ACCESSORIES

- FC Slicing Disc
- FCC Curved Slicing Discs
- FCO Rippled Slicing Discs
- FFC Chipping Grids
- FMC Dicing Grids
- FCE Julienne Discs
- FR/SH Shredding & Grating
- Discs
- Long vegetable attachment
- Universal hopper
- Disc and Grid Holder Device
- Automatic Hopper
- Grid Cleaning Kit



www.sammic.co.uk

Food Service Equipment Manufacturer

Unit 2, Trevanah Road
Troon Industrial Park
LE4 9LS - Leicester

uksales@sammic.com
Tel.: +44 0116 246 1900



Project

Date

Item

Qty

Approved

product sheet
updated 01/02/2019



VEGETABLE PREPARATION MACHINE CA-401 VV (VARIABLE SPEED)

Commercial vegetable preparation machine with an hourly output of up to 650 Kg.



SPECIFICATIONS

- Hourly production: 200 Kg - 650 Kg
- Inlet opening: 286 cm²
- Disc diameter: 205 mm
- Speeds as veg. slicer (positions): 5 (365 rpm - 1000 rpm)
- Total loading: 1500 W

External dimensions (WxDxH)

- Width: 391 mm
- Depth: 400 mm
- Height: 667 mm
- Net weight: 30 Kg
- Noise level (1m.): <70 dB(A)
- Background noise: 32 dB(A)

Crated dimensions

- 435 x 430 x 600 mm
- Gross weight: 35 Kg.

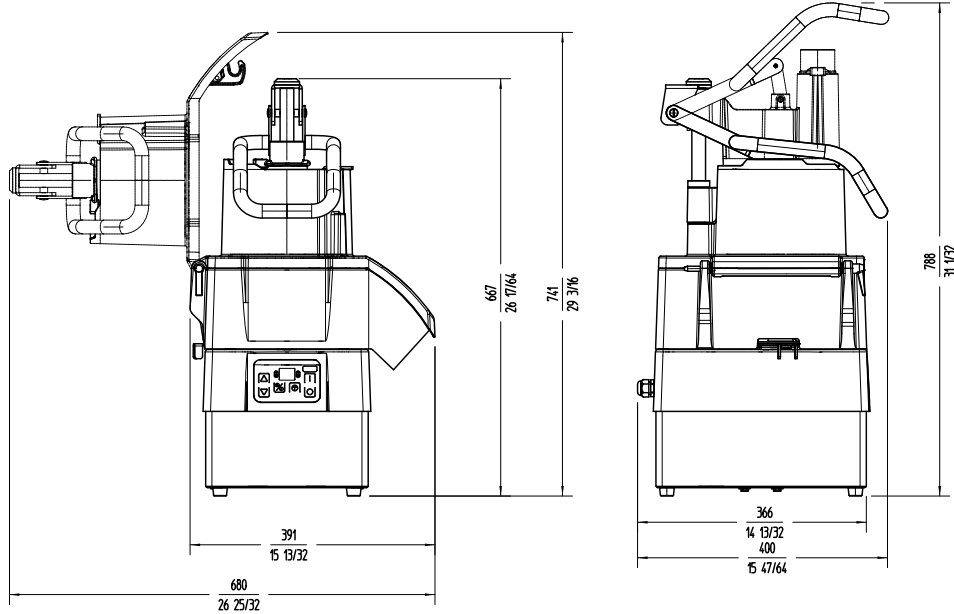

DYNAMIC PREPARATION
COMMERCIAL VEGETABLE PREPARATION MACHINES

AVAILABLE MODELS

1050356 Vegetable preparation machine CA-401VV 230/50-60/1 (variable speed)

* Ask for special versions availability



www.sammic.co.uk
Food Service Equipment Manufacturer
 Unit 2, Trevanth Road
 Troon Industrial Park
 LE4 9LS - Leicester
 uksales@sammic.com
 Tel.: +44 0116 246 1900



Project	Date
Item	Qty
Approved	

product sheet
updated 01/02/2019