



VEGETABLE PREPARATION MACHINE CA-41

High production vegetable preparation machine with an hourly output of up to 1300 lbs. / 650 Kg.



DYNAMIC PREPARATION
COMMERCIAL VEGETABLE PREPARATION MACHINES

SALES DESCRIPTION

Single-speed motor block + large production attachment.

A perfect cut

- ✓ High precision adjustments to obtain a uniform and excellent-quality cut.
- ✓ It can be fitted with a wide range of discs and grids of the highest cutting quality. Combining these accessories together to obtain more than 70 different types of cuts and grating grades.
- ✓ Head with blade on one side that distributes products inside the mouth and cuts and distributes whole products such as cabbage.
- ✓ Head equipped with high ejector: enables a higher quantity of product to be shifted.

Built to last

- ✓ Made from stainless steel and food-grade materials of the highest quality: stainless steel motor block and food-grade aluminium head.
- ✓ High power asynchronous motor.

Maximum comfort for the user

- ✓ Ergonomic design. Maximum comfort for the user.
- ✓ Lateral product output: requires less space on the worktop and guides the product, avoiding splashes.
- ✓ The electronic command panel is very intuitive.

Maintenance, safety, hygiene

- ✓ Lever and lid easily removable for cleaning purposes.
- ✓ Combination of safety systems: head, cover, power switch.
- ✓ Appliance certified by NSF International (regulations on hygiene, cleaning and materials suitable for contact with foods).
- ✓ 100% tested.

INCLUDES

- ✓ 1 speed motor block.
- ✓ Large capacity hopper.
- ✓ Core drill (optional use).

OPTIONAL

- Tube head.
- High production semi-automatic hopper.
- Support-trolley.
- Discs and grids.
- Grid cleaning kit.

ACCESSORIES

- FCC Curved Slicing Discs
- FCO Rippled Slicing Discs
- FFC Chipping Grids
- FMC Dicing Grids
- FCE Julienne Discs
- FR Shredding & Grating Discs
- Long vegetable attachment
- Disc and Grid Holder
- Automatic Hopper
- Grid Cleaning Kit
- FC-D Slicing Discs
- SH Shredding & Grating Discs

SPECIFICATIONS

Hourly production: 200 Kg - 650 Kg

Inlet opening: 286 cm²

Disc diameter: 205 mm

Motor speed: 365 rpm

Loading: 550 W

Electrical connection: --

Noise level (1m.): <70 dB(A)

Background noise: 32 dB(A)

External dimensions (WxDxH)

Width: 391 mm

Depth: 396 mm

Height: 652 mm

Net weight: 24 Kg

Crated dimensions

440 x 430 x 700 mm

Volume Packed: 0.13 m³

AVAILABLE MODELS

1050721	Vegetable preparation machine CA-41 230-400/50/3N
1050719	Vegetable preparation machine CA-41 230/50/1
1050720	Vegetable preparation machine CA-41 120/60/1
1050725	Vegetable preparation machine CA-41 220/60/1
1050726	Vegetable preparation machine CA-41 220-380/60/3N
1050731	Vegetable preparation machine CA-41 230/50/1

* Ask for special versions availability





VEGETABLE PREPARATION MACHINE CA-41

High production vegetable preparation machine with an hourly output of up to 1300 lbs. / 650 Kg.



DYNAMIC PREPARATION
COMMERCIAL VEGETABLE PREPARATION MACHINES

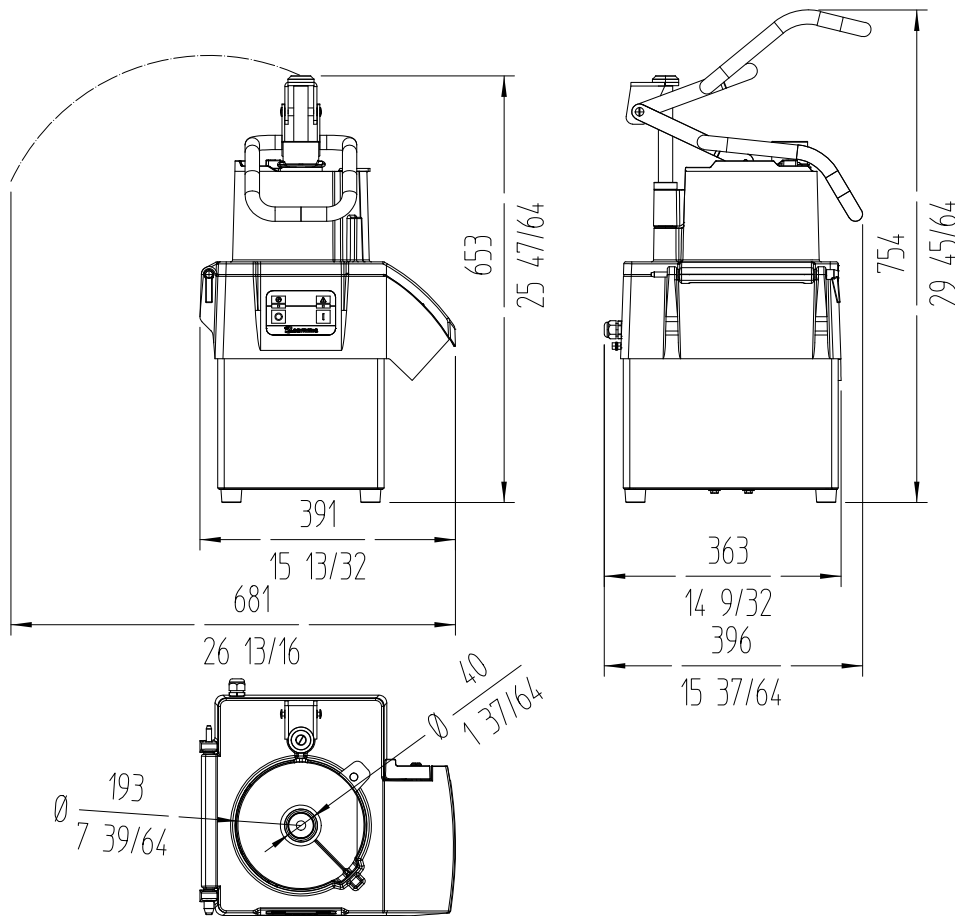

www.sammic.co.uk

Food Service Equipment Manufacturer

Unit 2, Trevanth Road
Troon Industrial Park
LE4 9LS - Leicester

uksales@sammic.com
Tel.: +44 0116 246 1900



Project

Date

Item

Qty

Approved

product sheet
updated 24/05/2022