



VEGETABLE PREPARATION MACHINE CA-4V 230/50-60/1

High-production Commercial vegetable preparation machine, up to 650 Kg.



1050796



- ✓ Advanced control panel that is very intuitive to use and offers all the information at a glance.

Maintenance, safety, hygiene

- ✓ Lever and lid easily removable for cleaning purposes.
- ✓ Combination of safety systems: head, cover, power switch.
- ✓ Appliance certified by NSF International (regulations on hygiene, cleaning and materials suitable for contact with foods).
- ✓ 100% tested.

INCLUDES

- ✓ Variable speed motor block.
- ✓ Large capacity head.
- ✓ Optional use drill.

OPTIONAL

- Tube head.
- High production semi-automatic hopper.
- Support-trolley.
- Discs and grids.
- Grid cleaning kit.

ACCESSORIES

- FCC Curved Slicing Discs
- FCO Rippled Slicing Discs
- FFC Chipping Grids
- FMC Dicing Grids
- FCE Julienne Discs
- FR Shredding & Grating Discs
- Long vegetable attachment
- Disc and Grid Holder
- Stand-trolley
- Grid Cleaning Kit
- FC-D Slicing Discs
- SH Shredding & Grating Discs

SPECIFICATIONS

Hourly production: 200 Kg - 650 Kg

Inlet opening: 286 cm²

Disc diameter: 205 mm

Speed as veg. slicer: 300 rpm - 1000 rpm

Total loading: 1500 W

Electrical supply: 230 V / 50-60 Hz / 1 ~ (10 A)

Plug: EU (SCHUKO 2P+G)

External dimensions (WxDxH)

Width: 391 mm

Depth: 400 mm

Height: 652 mm

Net weight: 27 Kg

Crated dimensions

445 x 430 x 595 mm

Volume Packed: 0.13 m³

Gross weight: 31.2 Kg

SALES DESCRIPTION

Variable speed motor block + high-production head. Equipped with “brushless” technology.

Equipped with “brushless” technology: powerful and efficient motors.

- ✓ Maximum efficiency: maintain the torque throughout the speed range.
- ✓ Exclusive “force control system”: guarantee of a uniform and high quality cut.
- ✓ Lightweight and compact design: they weigh less, they occupy less space.
- ✓ Improved air/water-tightness since no ventilation is required.
- ✓ They generate less noise: improved workplace environment.

A perfect cut

- ✓ High precision adjustments to obtain a uniform and excellent-quality cut.
- ✓ It can be fitted with a wide range of discs and grids of the highest cutting quality. Combining these accessories together to obtain more than 70 different types of cuts and grating grades.
- ✓ Head with blade on one side that distributes products inside the mouth and cuts and distributes whole products such as cabbage.
- ✓ Head equipped with high ejector: enables a higher quantity of product to be shifted.
- ✓ Exclusive “Force Control System” to optimise and standardise the cutting of each product: acoustic warning when the motor exceeds the pre-established force.

Built to last

- ✓ Made from stainless steel and food-grade materials of the highest quality: stainless steel motor block and food-grade aluminium head.

Maximum comfort for the user

- ✓ Ergonomic design. Maximum comfort for the user.
- ✓ Lateral product output: requires less space on the worktop and guides the product, avoiding splashes.

DYNAMIC PREPARATION
COMMERCIAL VEGETABLE PREPARATION MACHINES

product sheet
updated 24/05/2022





VEGETABLE PREPARATION MACHINE CA-4V 230/50-60/1

High-production Commercial vegetable preparation machine, up to 650 Kg.



1050796

DYNAMIC PREPARATION
COMMERCIAL VEGETABLE PREPARATION MACHINES

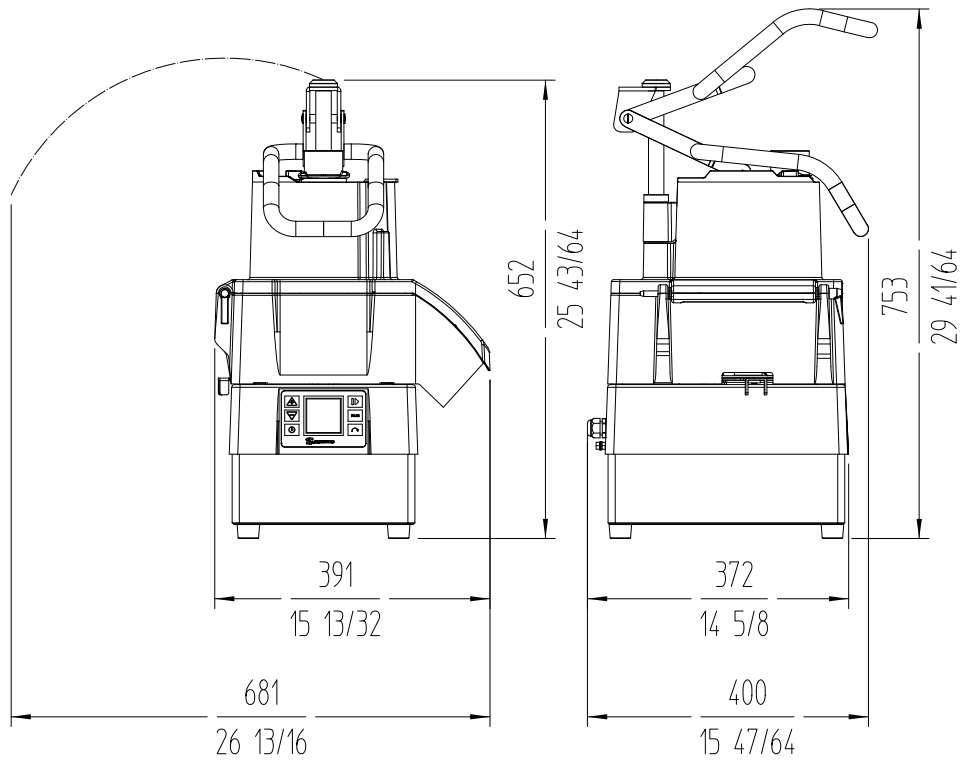

www.sammic.co.uk

Food Service Equipment Manufacturer

Unit 2, Trevanah Road
Troon Industrial Park
LE4 9LS - Leicester

uksales@sammic.com
Tel.: +44 0116 246 1900



Project	Date
Item	Qty
Approved	

product sheet
updated 24/05/2022