



# VEGETABLE PREPARATION MACHINE CA-62 400/50/3

High-production vegetable cutter, up to 1000 Kg.



1050738



## INCLUDES

- ✓ Two-speed motor block.
- ✓ High production semi-automatic hopper.

## OPTIONAL

- Large capacity head.
- Discs and grids.
- Tube head.
- Grid cleaning kit.
- Support-trolley.

## SPECIFICATIONS

**Hourly production:** 500 Kg - 1000 Kg

**Inlet opening:** 273 cm<sup>2</sup>

**Disc diameter:** 205 mm

**Motor speed:** 365-730 rpm

**Loading:** 750 W

**Electrical supply:** 400 V / 50 Hz / 3 ~ (2.3-2.5 A)

**Plug:** --

Electrical connection: 3P+G

**Noise level (1m.):** <70 dB(A)

**Background noise:** 32 dB(A)

### External dimensions (WxDxH)

Width: 430 mm

Depth: 420 mm

Height: 810 mm

**Net weight:** 29.5 Kg

### Crated dimensions

480 x 480 x 740 mm

Volume Packed: 0.17 m<sup>3</sup>

Gross weight: 34 Kg

## SALES DESCRIPTION

Two-speed motor block + high-production semi-automatic hopper.  
3-phase only

### A perfect cut

- ✓ High precision adjustments to obtain a uniform and excellent-quality cut.
- ✓ It can be fitted with a wide range of discs and grids of the highest cutting quality.
- ✓ Combining these accessories together to obtain more than 70 different types of cuts and grating grades.
- ✓ Head equipped with high ejector: enables a higher quantity of product to be shifted.

### Built to last

- ✓ Made from stainless steel and materials of the highest quality and suitable for food contact: stainless steel motor block and hopper and food-grade aluminium head.
- ✓ High power asynchronous motor.

### Maximum comfort for the user

- ✓ Ergonomic design. Maximum comfort for the user.
- ✓ Lateral product output: requires less space on the worktop and guides the product, avoiding splashes.
- ✓ The electronic command panel is very intuitive.

### Maintenance, safety, hygiene

- ✓ Hopper and lid easily removable for cleaning.
- ✓ Combination of safety systems: hopper, cover, power switch.
- ✓ Appliance certified by NSF International (regulations on hygiene, cleaning and materials suitable for contact with foods).
- ✓ 100% tested.

DYNAMIC PREPARATION  
COMMERCIAL VEGETABLE PREPARATION MACHINES

product sheet  
updated 18/03/2022





# VEGETABLE PREPARATION MACHINE CA-62 400/50/3

High-production vegetable cutter, up to 1000 Kg.



1050738

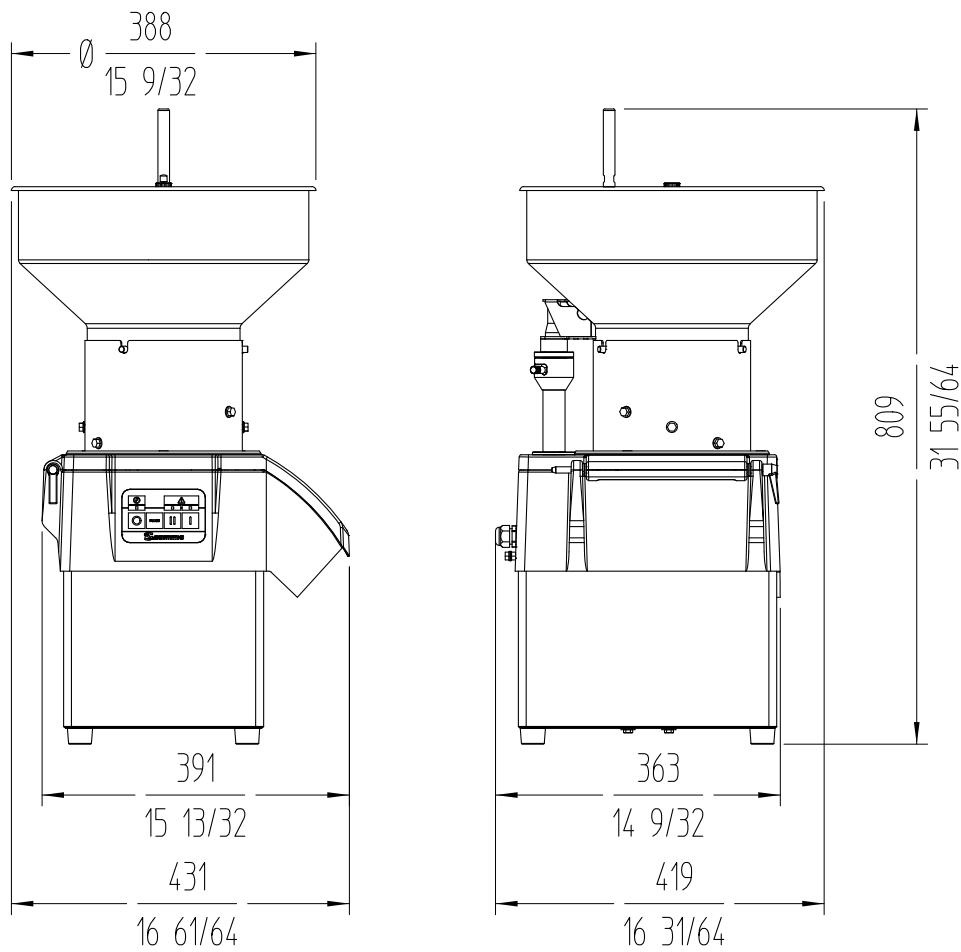

DYNAMIC PREPARATION  
COMMERCIAL VEGETABLE PREPARATION MACHINES

**www.sammic.co.uk**

**Food Service Equipment Manufacturer**

Unit 2, Trevanth Road  
Troon Industrial Park  
LE4 9LS - Leicester

uksales@sammic.com  
Tel.: +44 0116 246 1900

Project	Date
Item	Qty
Approved	

product sheet updated 18/03/2022