



SHELVING for LIFE

Camshelving® Premium, Elements and Basics Plus Series



CAMBRO
TRUSTED FOR GENERATIONS™



Premium Series High Density Shelving



Elements Series Walk-In Cooler

When we say Shelving for Life, we mean it. All Camshelving® storage systems are designed to withstand the toughest conditions and the harshest environments. With our lifetime warranty against rust and corrosion, only Cambro offers SHELIVING for LIFE.



Premium Series Walk-In Cooler



Basics Plus Series Utility Storage



Elements Series Mobile Drying Rack



Premium Series Utility Storage

Camshelving® SHELVING for LIFE



Rust and Corrosion Free

Backed by a lifetime warranty against rust and corrosion. All Camshelving is impervious to harsh chemicals and salt water.

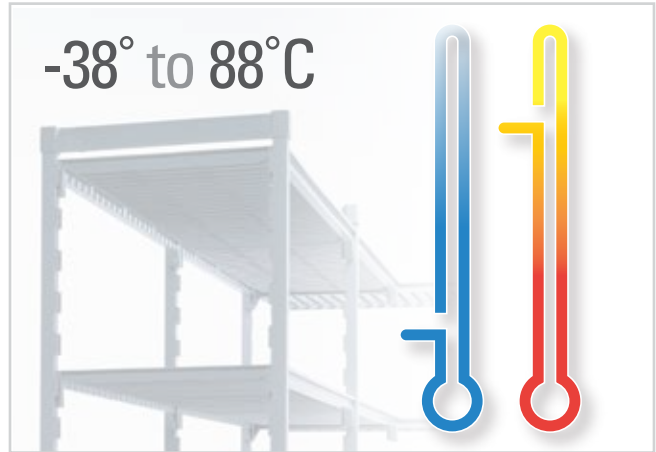

All Environments

Camshelving is designed to withstand all extreme storage applications and temperatures.

- Coolers
- Freezers
- Dry Storage
- Utility

Maximized Space Utilization

Shelving units are designed to be interconnected, without compromising weight-bearing capacity, all while maximizing usable storage space.

Starter Unit

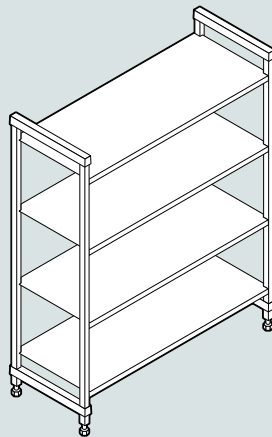

Starter + Add-On Unit

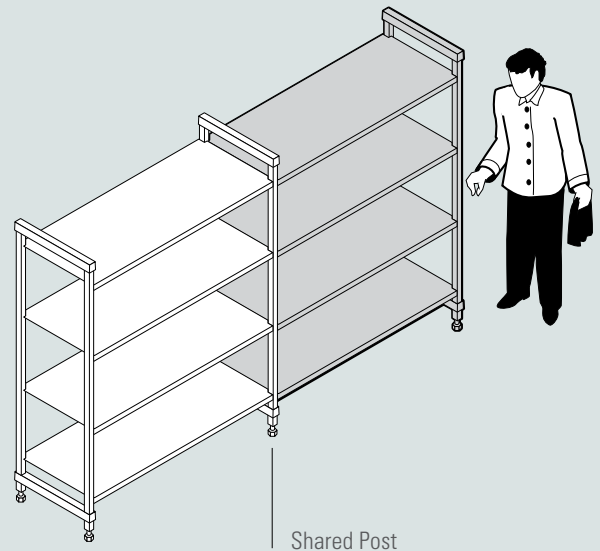



Easy to Clean

Camshelving easily wipes clean or shelf plates can go through the dishwasher. Camguard® antimicrobial shelf plates inhibit the growth of harmful bacteria and microbes.



Easy to Assemble & Adjust

Units ship with preassembled frames to speed up installation. Each shelf can be easily and independently adjusted.

**Corner Unit
Starter + Add-On Unit**

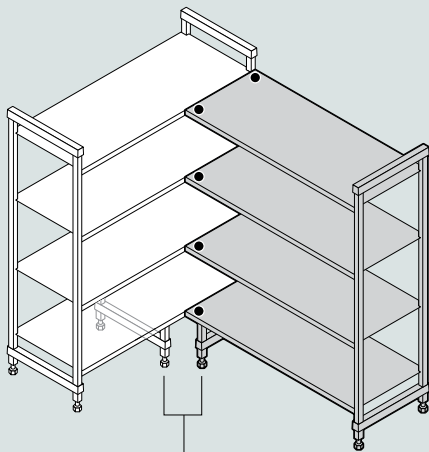

**U-Shape Unit
Two Starter Units + Intermediate Shelves**

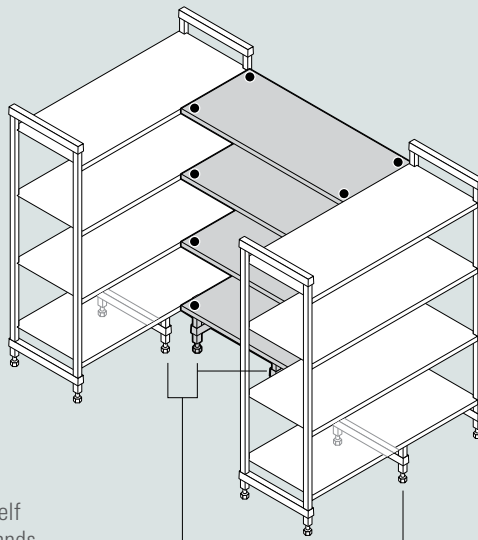

**T-Shape Unit
Starter unit + Add-on**

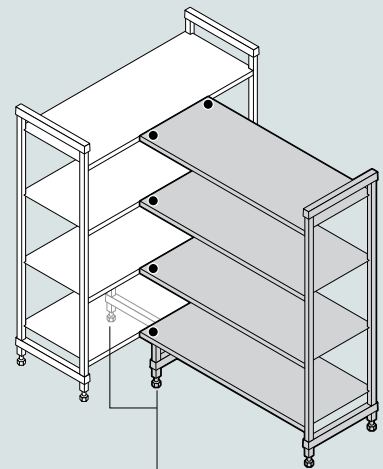

Bottom Shelf
Dunnage Stands

Convert unusable space into continuous, easy-access storage areas with corner connectors. Corner units are for use with certain sizes only.

Camshelving® PREMIUM series

STATIONARY | MOBILE | HIGH DENSITY

Why Choose Premium?

- Easy to clean.
- Quick and easy to assemble.
- Ideal for coolers, freezers and warewashing areas.
- Strong enough to support the toughest loads.
- Impervious to harsh chemicals and salt water.



camguard
ANTIMICROBIAL SHELF PLATES



COMPONENT

Post Connectors, Corner Connectors, Seismic Foot, Wall Fastener, Identification Tags, Full Wrap Security Cage, Single Shelf Security Cage, Single Shelf Sheet Pan/Tray Rack, Shelf Rails, Shelf Divider Bars, High Density Track and Extension Kits are not NSF Listed.



Camshelving® ELEMENTS series

STATIONARY | MOBILE | UNDERCOUNTER

Why Choose Elements?

- Easy to clean and adjust.
- Ideal for coolers, freezers and warewashing areas.
- Made from extremely strong composite and plastic materials.
- Impervious to harsh chemicals and salt water.



camguard
ANTIMICROBIAL SHELF PLATES



COMPONENT

Post Connectors, Corner Connectors, Seismic Foot, Wall Fastener, Identification Tags, Single Shelf Security Cage, Single Shelf Sheet Pan/Tray Rack, and Shelf Divider Bars are not NSF Listed.



Camshelving® **BASICS PLUS** series

STATIONARY

Why Choose Basics Plus?

- Easy to clean and adjust.
- Superior alternative to wire or aluminum shelving.
- Ideal for coolers, freezers, warewashing areas and dry storage.
- Made from extremely strong composite and plastic materials.
- Impervious to harsh chemicals and salt water.



COMPONENT

Post Connectors, Corner Connectors, Seismic Foot, Wall Fastener, Single Shelf Security Cage, Single Shelf Sheet Pan/Tray Rack, and Identification Tags are not NSF listed.



Camshelving® Series Accessories

Make the most of your Camshelving by adding accessories to create the perfect storage system for your needs.

Support and Weight Bearing

PREMIUM
ELEMENTS
BASICS PLUS



Additional Traverses



Wall Fastener



Seismic Foot

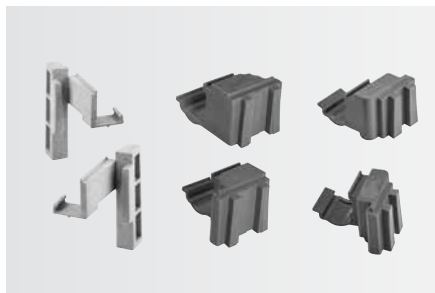

Corner Connectors



Bottom Shelf Dunnage Stands

Mobility

PREMIUM
ELEMENTS



Premium Caster with Bumper



Premium Series High Density Caster with Bumper



Elements Series Donut Bumper

Security

PREMIUM
ELEMENTS
BASICS PLUS



Full-Wrap Stainless Steel Security Cage
PREMIUM



Single Shelf Stainless Steel Security Cage
PREMIUM | ELEMENTS | BASICS PLUS

Camshelving® Series Accessories

Organization

PREMIUM
ELEMENTS
BASICS PLUS



Identification Tags



Shelf Divider Panel



Single Shelf Sheet Pan/Tray Rack



Shelf Rails
PREMIUM | **ELEMENTS**



Shelf Divider Bars
PREMIUM | **ELEMENTS**

Drying Cradles

PREMIUM
ELEMENTS
BASICS PLUS

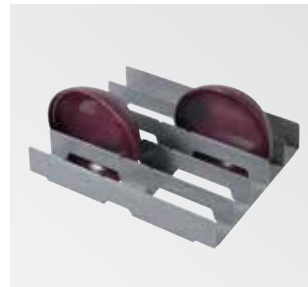

Dome Drying and Storage Cradle



Vertical Drying and Storage Cradle



Angled Drying and Storage Cradle

Drying Racks

PREMIUM
ELEMENTS



Dome Drying and Storage Rack



Vertical Drying and Storage Rack



Angled Drying and Storage Rack

Camshelving® Series Buyers Guide

All Camshelving lines offer a lifetime warranty against rust and corrosion for shelf plates, posts and traverses.



PREMIUM series



ELEMENTS series



BASICS PLUS series

| | | | |
|--------------------------------|---|---|---|
| Frequency of Delivery | Frequent and/or multiple daily deliveries. | 4-7 deliveries per week. | 2-4 deliveries per week. |
| Durability | Can withstand constant loading and off-loading of medium to heavy products. | Can withstand constant loading and off-loading of medium to heavy products. | Can withstand constant loading and off-loading of light to medium products. |
| Assembly | Moulded in dovetails means fewer parts, easiest to assemble. | Easy to assemble. | Easy to assemble. |
| Weight-Bearing Capacity | Can withstand up to 800kg per unit. | Can withstand up to 910kg per unit. | Can withstand up to 800kg per unit. |
| Construction | Strong steel core | Composite material | Composite material |
| Styles | Starter, add-on and mobile units. | Starter, add-on and mobile units. | Starter and add-on units. |

| ACCESSORIES | | | |
|--|---|---|---|
| Bottom Shelf Dunnage Stand | ✓ | ✓ | ✓ |
| Shelf Rails | ✓ | ✓ | |
| Vertical Drying and Storage Cradle (Trays / Cutting Boards / Lids) | ✓ | ✓ | ✓ |
| Dome Drying and Storage Cradle | ✓ | ✓ | ✓ |
| Angled Drying and Storage Cradle | ✓ | ✓ | ✓ |
| Shelf Divider Panel | ✓ | ✓ | ✓ |
| Shelf Divider Bar (for Food Pans or Food Boxes) | ✓ | ✓ | |
| Single Shelf Sheet Pan/Tray Rack | ✓ | ✓ | ✓ |
| Single Shelf Security Cage | ✓ | ✓ | ✓ |
| Full Wrap Security Cage | ✓ | | |



Premium Series Walk-in Cooler



Elements Series Dry Storage



Visit the Camshelving website at www.cambro.com/camshelving for product information and pricing on ALL available shelving products.



Elements Series Undercounter Storage

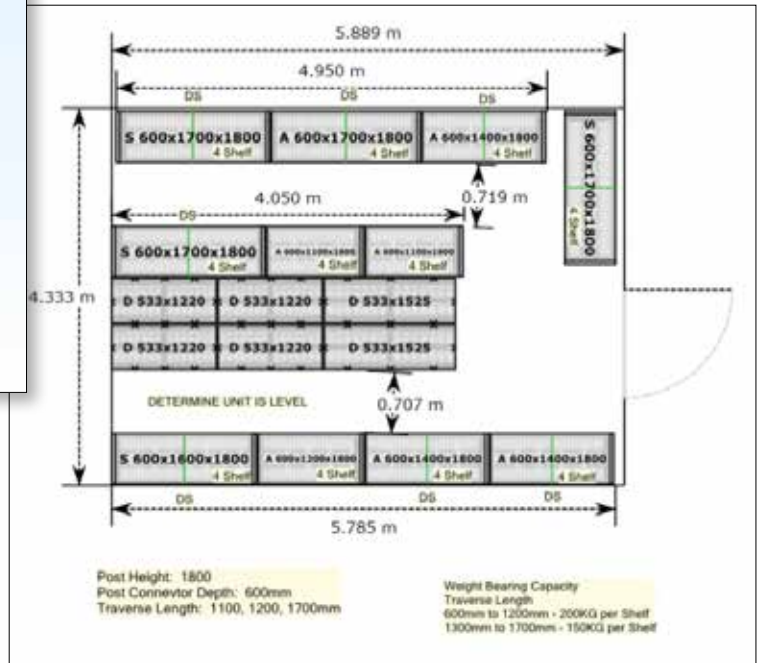

FREE Camshelving® Design Service

Take the guesswork out of creating your perfect shelving layout. Let our expert shelving consultants prepare a free layout that optimizes your space to create the most storage options. Here's what you'll get:

- 2D Floor Plan
- 3D Floor Plan
- Itemized product list by room/area
- All within 48 business-day hours



Scan the QR code to get started today.



It's Simple! To Get Started, Please Provide:

- Project Name
- Storage Room Type (freezer / cooler)
- Room(s) Dimensions (L x W x H)
- Doorway / Entryway Location & Dimension
- Obstructions (condenser / pipes)
- Additional Preferences / Requirements

Foodservice Equipment Marketing is the master distributor for Camshelving products in the UK and Ireland. We look forward to designing the perfect storage solution for you. Call or email today to connect with one of our Camshelving consultants.

E: sales@fem.co.uk

T: 01355 244 111

W: www.fem.co.uk

