

Commercial Chest Freezer

CF450WH

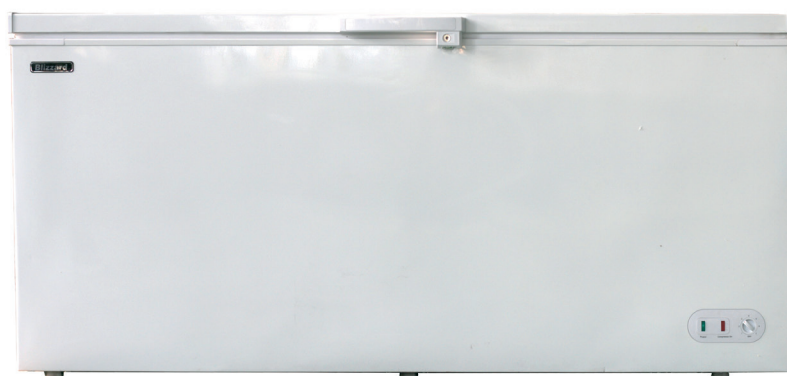

CF650WH



CF550WH

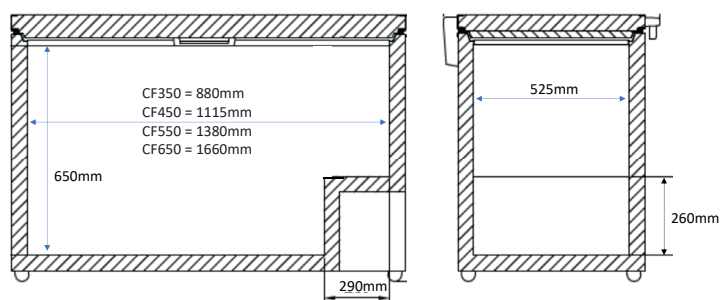

FEATURES

- White laminated exterior including lid
- Stippled aluminium interior
- Roll bond maintenance free condenser
- Lock fitted as standard
- Rollers fitted as standard
- Replaceable door gasket

TECHNICAL SPECIFICATIONS

Controller:	Manual thermostat
Cooling:	Static
Defrost:	Manual
Refrigerant:	R600a
Climate Class:	4
Temperature Range:	-18°C ~ -22°C
Decibels:	48dBA
Power Supply:	13amp

MODEL	GROSS CAPACITY	BASKETS SUPPLIED	MAX. BASKETS	EXT. DIMENSIONS (H x W x D mm)	ENERGY RATING	POWER CONSUMPTION	KWH /ANNUM	WEIGHT (kg)	RRP
CF350WH	350L	1	3	840 x 1030 x 755	F	64W	268	57.5	
CF450WH	450L	1	4	840 x 1270 x 755	F	138W	302	65.5	
CF550WH	550L	2	5	840 x 1530 x 755	F	161W	323	75	
CF650WH	650L	2	6	840 x 1810 x 755	F	161W	382	83.5	

