

Warewashing Hood type Dishwasher with ZERO LIME Device



Warewashing

Hood type Dishwasher with ZERO LIME Device

CK2575

Hood type dishwasher, with single skin manual hood, atmospheric boiler, ZERO LIME Device, built-in detergent dispenser, rinse aid dispenser and drain pump, 80r/h

Short Form Specification

Item No.

Hood type hot water rinsing dishwasher. Electrical characteristics to be ___400 volts, three phase 50Hz operation, convertible to single phase on-site. Uses 2 liters of clean water per final rinse cycle. 84°C rinse temperature and pressure guaranteed by built in atmospheric boiler and built in rinse booster pump. Washing performance is guaranteed by a powerful 0.8 kW wash pump and upper and lower stainless steel revolving washing spray arms. ZERO LIME Device automatically de-scales the whole hydraulic circuit and washing chamber. 304 Stainless steel construction to include single skin hood, external, front and side panels, wash tank, tank filter plus wash and rinse arms. Unit shall be field convertible from straight to corner operation. The unit shall include drain pump, rinse aid dispenser pump and detergent dispenser pump and is equipped with flexible fill hoses. Delivered on height-adjustable feet.

Main Features

- ZERO LIME Device ensures total scale removal from the boiler, the hydraulic circuits and the washing chamber allowing ultimate performances and lower energy consumption thanks to the high-efficiency heating element.
- ETL-Sanitation approved (ANSI/NSF 3 sanitation standard) and DIN 10512 compliant.
- Requires only 2 liters of water per washing cycle thus ensuring low energy, water, detergent and rinse aid consumption.
- Built-in atmospheric boiler sized to raise incoming water to a minimum of 84 °C for sanitizing rinse. No external booster is required. Constant temperature of 84 °C throughout the rinsing cycle regardless of the network's water pressure.
- Unique temperature interlock guarantees required temperatures in both the wash and final rinse.
- Maximum capacity per hour of 80 racks or 1.440 dishes (High productivity mode) easy to switch to 63 racks or 1.134 dishes (ETL-Sanitation mode) by pressing a button.
- 45/84/150 seconds cycles (High productivity mode); 57/84/150 seconds cycles (ETL-Sanitation mode).
- Incorporated Soft Start feature to offer additional protection to more delicate items.
- Cycle may be interrupted at any time by lifting the hood.
- Automatic self-cleaning cycle and self-draining vertical wash pump and boiler to avoid bacteria proliferation.
- State-of-the-art electronic controls with built-in programming, self-diagnostics for serviceability and automatic interior self-cleaning cycle.
- Boiler power setting from control panel to facilitate technician's operation when reducing total installed power, thus avoiding the need of machine opening.
- Three phase electrical connection, convertible to single phase on-site.
- IP25 protection against water jet, solid objects and small animals (larger than 6 mm).
- Slanted wash arms to avoid detergent-filled wash water dropping on clean dishes after the rinsing phase, thus guaranteeing ideal washing results.
- Built-in rinse aid and detergent dispenser with automatic initial and continuous cycle loading for perfect result while minimizing service and maintenance needs.
- WRAS approved product.

Construction

- Heavy duty Stainless steel construction. Internal cavity as well as exterior panels are in 304 series Stainless steel.
- Pressed tank in front position to facilitate cleaning.
- Specially designed Stainless steel wash/rinse arms and nozzles provide superior cleaning action.
- Revolving interchangeable Stainless steel wash/rinse arms above and below the rack, screw out for simple clean up.
- Pre-arranged for on-site HACCP implementation and Energy Management device.
- Element protection from dry fire and low water.
- Single skin hood supported by 3 springs to ensure smooth movement and guarantee operator safety.
- Unit to include drain, detergent and rinse aid dispenser pumps

APPROVAL: _____



Warewashing Hood type Dishwasher with ZERO LIME Device

Included Accessories

- 1 of YELLOW CUTLERY CONTAINER PNC 864242
- 1 of BASKET FOR 18 DINNER PLATES 240MM-YELLOW PNC 867002
- 1 of BASKET FOR 48 SMALL CUPS/24 CUPS-BLUE PNC 867007

Optional Accessories

- KIT 8 PLASTIC BOXES FOR CUTLERY-YELLOW PNC 780068
- 12 L EXTERNAL MANUAL WATER SOFTENER PNC 860412
- 8 L EXTERNAL AUTOMATIC WATER SOFTENER PNC 860413
- 20 L EXTERNAL MANUAL WATER SOFTENER PNC 860430
- HACCP PRINTER KIT FOR UC, HT AND POTW PNC 864002
- HACCP KIT WITH CABLE SINGLE SKIN HOOD T PNC 864006
- STAINLESS STEEL INLET HOSE KIT PNC 864016
- FILTER FOR PARTIAL DEMINERALIZATION PNC 864017
- KIT TO MEASURE TOTAL/PART.WATER HARDNESS PNC 864050
- YELLOW CUTLERY CONTAINER PNC 864242
- ADVANCED FILTERING SYSTEM KIT HOOD T. PNC 864329
- FILTER FOR TOTAL DEMINERALIZATION PNC 864367
- FRONTAL CONTROL PANEL FOR SINGLE SKIN HT PNC 864374
- REVERSE OSMOSIS-SINGLE TANK ATMOSPH. DW PNC 864388
- HANDLE CONNECTION KIT FOR DUET MANUAL HT PNC 865264
- KIT 4 PLASTIC BOXES FOR CUTLERY-YELLOW PNC 865574
- BASKET FOR 6 TRAYS 530X370MM-RED PNC 866743
- BASKET FOR 12 SOUP BOWLS 240MM-GREEN PNC 867000
- BASKET FOR 18 DINNER PLATES 240MM-YELLOW PNC 867002
- BASKET FOR 48 SMALL CUPS/24 CUPS-BLUE PNC 867007
- BASKET FOR BULK CUTLERY-BROWN PNC 867009
- COVER GRID FOR SMALL/LIGHT ITEMS IN RACK PNC 867016
- BASKET F.25 TILTED GLASSES (H120MM)-BLUE PNC 867021
- BASKET F.16 VERTIC.GLASSES (H70MM)-BLUE PNC 867023
- BASKET SEMI-PROFESSIONAL 500X500X190MMPNC 867024
- BASKET F.16 TILTED GLASSES (H220MM)-BLUE PNC 867040

Front

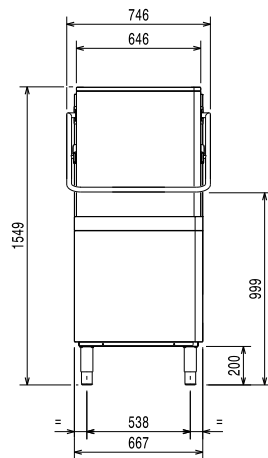

Top

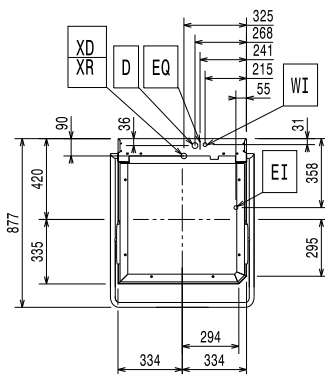

- CWI** = Cold Water inlet
- D** = Drain
- EI** = Electrical connection
- EQ** = Equipotential screw
- HWI** = Hot water inlet
- V** = Air vents
- WI** = Water inlet
- XD** = Detergent connection
- XI** = Chemicals inlet
- XR** = Rinse aid connection

Side

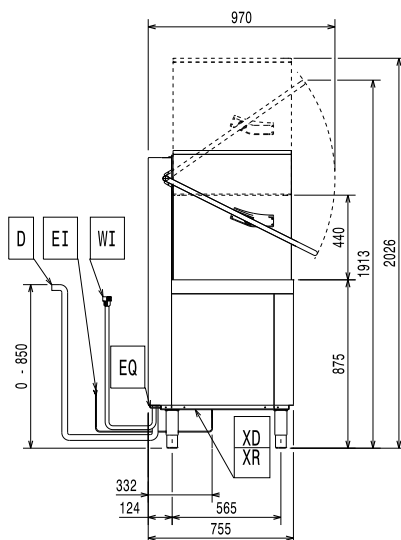

Electric

Supply voltage:	400 V/3N ph/50 Hz
CK2575	
Convertible to:	230V 3~; 230V 1N~ 50Hz
Default Installed Power:	9.9 kW
Reducible Installed Power:*	6.9 kW
Boiler Heating Elements Power:*	9 kW
Boiler Reducible To:*	6 kW
Tank heating elements:	3 kW
Wash pump size:	0.8 kW

Water:

Water supply temperature:	10-65 °C
Water consumption per cycle (lt):	2
Boiler Capacity (lt):	12
Tank Capacity (lt):	24
Drain line size:	20.5 mm
Inlet Water supply pressure:	0.5 - 7 bar

Key Information:

N° of cycles:	3
Duration cycle - High productivity:*	45/84/150 sec.
Duration cycle - Thermal Label compliant:	57/84/150 sec.
Racks per hour - High productivity: *	80
Racks per hour - Thermal Label compliant:	63
Dishes per hour - High productivity: *	1440
Dishes per hour - Thermal Label compliant:	1134
Wash temperature - High productivity:	55-65 °C
Wash temperature - Thermal Label compliant:	75 °C MIN
Rinse temperature (MIN):	84 °C
External dimensions, Height:	1549 mm
External dimensions, Width:	746 mm
External dimensions, Depth:	755 mm
Net weight:	106 kg
Shipping weight:	118 kg
Shipping volume:	1.25 m ³
Packaging size (WxDxH):	746x755x1547 mm
Noise level:	<68 dBA

* According to market standard, the productivity is declared at an inlet water supply temperature of 50°C . If the water is supplied at 65°C, the power can be reduced by 3 kW without any loss in productivity.

NOTE:

If the water supply temperature is less than 50°C, it is necessary to request higher power to maintain productivity.

Recommended table connection

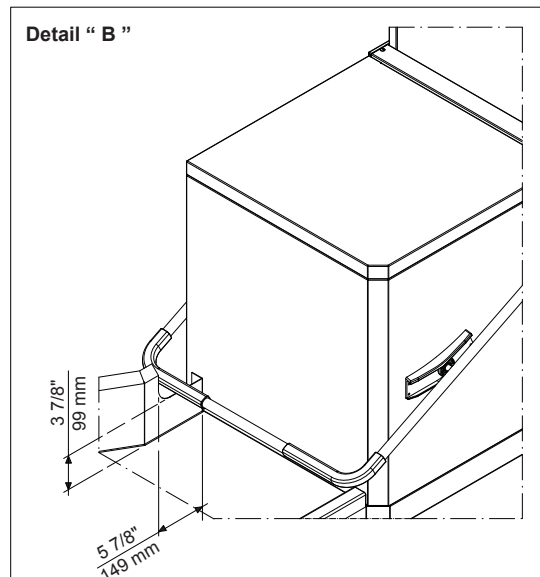
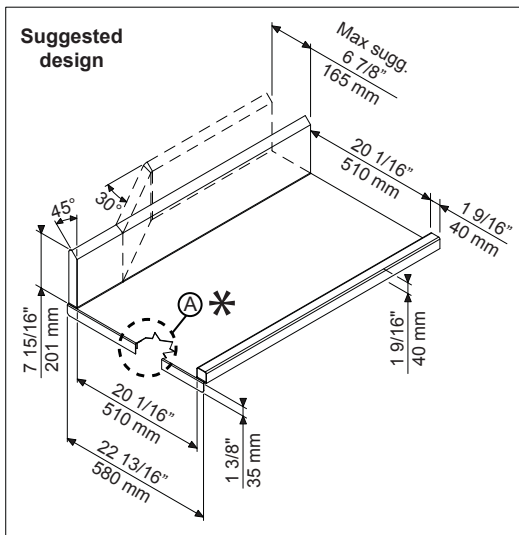
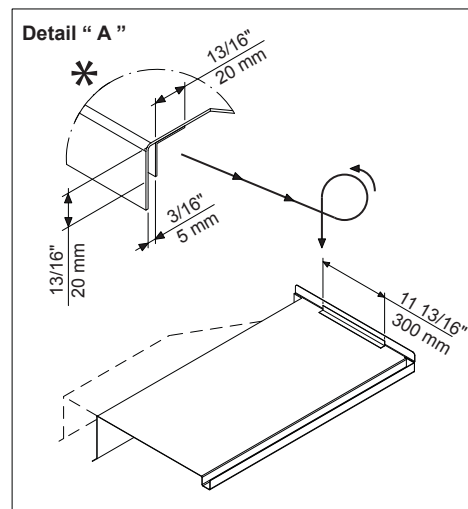
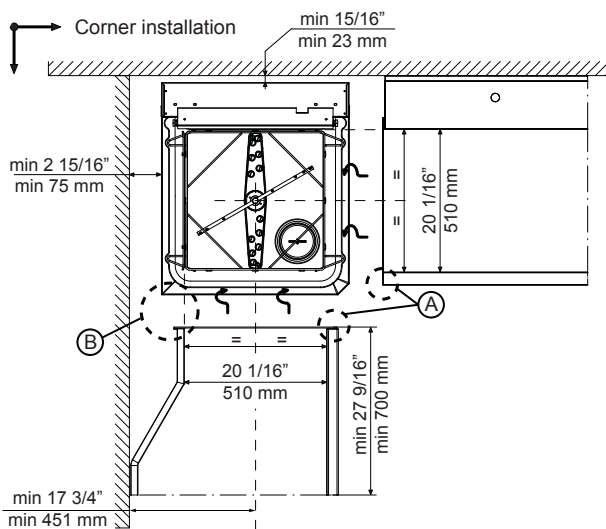
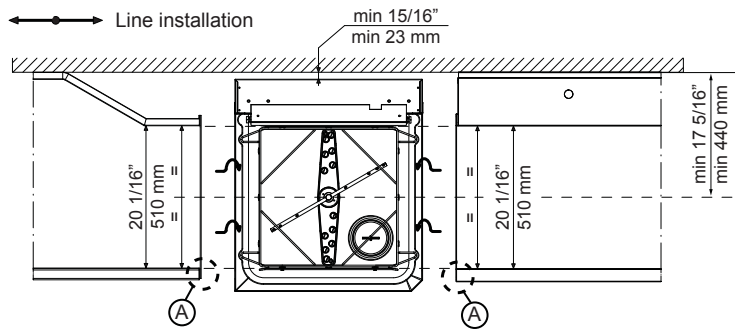

All tables must be connected to the dishwashing units according to local regulations and industry standards which may differ from the recommendations herein suggested. Electrolux Professional is not liable for any failure in complying with local design standards.

Doc Nr : 59566BF00