



FOOD-PROCESSOR CK-8

Capacity of the bowl: 8 lt. / 8 1/2 qt. 2-speed appliance.



DYNAMIC PREPARATION
CUTTER-MIXERS & EMULSIFIERS



FEATURES AND BENEFITS

- ✓ Stainless steel construction and highest quality material, all suitable for contact with food.
- ✓ It consists of a 2-speed motor block with a regular hopper and a 8 lt. food processor bowl complete with a hub with serrated blades.
- ✓ Strong, very easy to use and clean.
- ✓ High production. Ventilated motor allowing continuous use.
- ✓ User-friendly, waterproof led-lit control panel.
- ✓ Allows programming by time and includes a pulse switch
- ✓ In option: "Cut&Mix" scraper.

INCLUDES

- ✓ 8 litre bowl complete with a hub with serrated blades.

SALES DESCRIPTION

It consists of a motor block and a 8-litre / 8 1/2 qt. bowl complete with a hub with serrated blades.

3-phase only.



SAMMIC, S.L.
Basiglio, 1 - 20720 ASK011TA
www.sammic.com



www.sammic.co.uk

Food Service Equipment Manufacturer

Unit 2, Trevanah Road
Troon Industrial Park
LE4 9LS - Leicester

uksales@sammic.com
Tel.: +44 0116 246 1900



Project

Date

Item

Qty

Approved

product sheet
updated 06/03/2018



FOOD-PROCESSOR CK-8

Capacity of the bowl: 8 lt. / 8 1/2 qt. 2-speed appliance.



SPECIFICATIONS

Bowl capacity: 8 l
Bowl dimensions: Ø240 mm x 240 mm
Total loading: 900-1500 W - 1500 W
Speed, min-max: 1500 rpm / 3000 rpm

External dimensions (WxDxH)

- ✓ Width: 284 mm
- ✓ Depth: 374 mm
- ✓ Height: 488 mm

Net weight: 23 Kg

Crated dimensions

400 x 310 x 570 mm
Gross weight: 25 Kg.

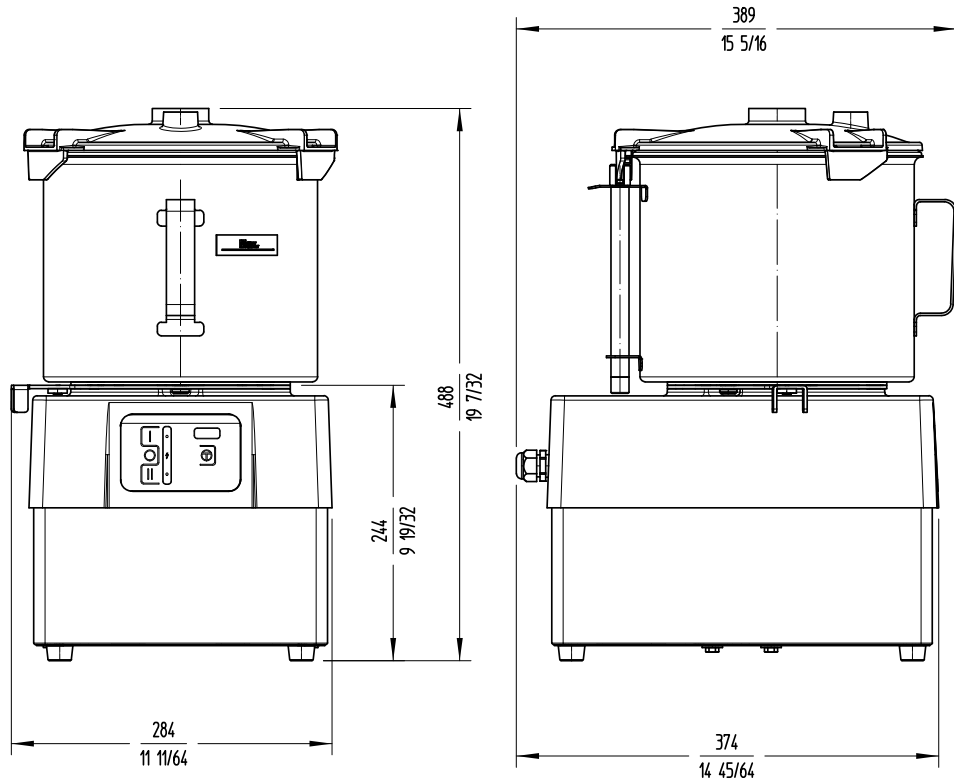

AVAILABLE MODELS

1050150 Cutter CK-8 2V 400/50/3

* Ask for special versions availability

ACCESSORIES

- Blades for CK/CKE
- "Cut&Mix" Scrapers CK/CKE

DYNAMIC PREPARATION
CUTTER-MIXERS & EMULSIFIERS



www.sammic.co.uk

Food Service Equipment Manufacturer

Unit 2, Trevanah Road
Troon Industrial Park
LE4 9LS - Leicester

uksales@sammic.com
Tel.: +44 0116 246 1900



Project

Date

Item

Qty

Approved

product sheet
updated 06/03/2018