



E9781-150 Electric Boiling Pan



Short Form Specification

Unit to be Falcon F900 Series electric boiling pan having a 150 litre capacity pan to be supplied upon adjustable feet. Exterior panels are Scotch Brite finish stainless steel.

The hob will be constructed from 2mm 304 grade stainless steel. Hobs will be laser cut with right-angled edges to allow joining of units with no gaps between hobs. Exterior panels are Scotch Brite finish stainless steel. Control knobs to have a bezel behind each knob to prevent water ingress.

Key Features

- 150 litre capacity stainless steel pan
- Integrated water faucet as standard
- Counter-balanced lid
- Supplied upon adjustable stainless steel feet
- 2mm thick 304 grade stainless steel hob
- Laser cut hob allows edge to edge joining of units
- Stainless steel external panels with Scotch Brite finish
- Dynamic Link System Compatible



Integrated linking system allows gap free installation to create a seamless, continuous cookline.

UK Patent No. 2540131

Optional Accessories

- Front hob rail
- Vented front kick strip
- Side kick strips RH/LH
- Rear blanking plate
- Side hob extension
- Castors

E9781-150 Electric Boiling Pan

Model Dimensions (mm)

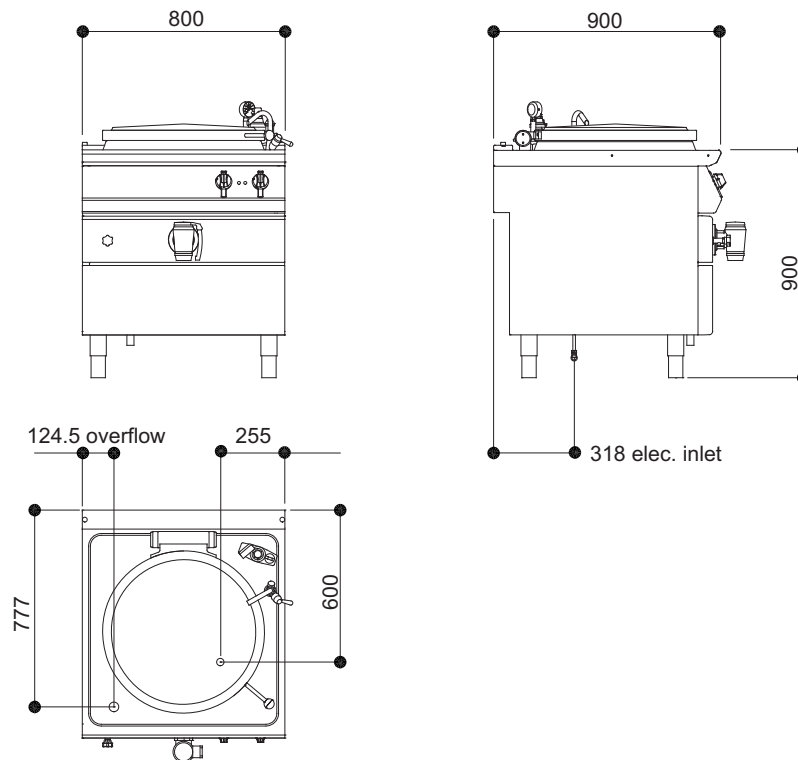

Specification Details

Electrical rating (kW)	16
Electrical supply voltage	400V 3N~ 50/60Hz
Required electrical supply (A)	32
Electrical current split (A)	L1: 23.1, L2: 23.1, L3: 23.1
Element rating (kW)	16
Water capacity (litres)	150
Water connection	3/4" BSP
Water pressure (kPa)	50 - 300
Weight (kg)	140
Packed weight (kg)	165
Packed dimensions (mm)	870 (w) x 1070 (d) x 1270 (h)

Installation Note:

Please consult local legislation with regard to installation of cooking equipment.