

PROJECT	QUANTITY	ITEM NO
---------	----------	---------

# Evolution Elite® Open Fryers



- EEG 241** 1-well gas
- EEG 242** 2-well gas
- EEG 243** 3-well gas
- EEG 244** 4-well gas



EEG 243 3-well gas open fryer



Oil replenished automatically from JIB for multi-well (left) or reservoir for 1-well (right)

Henny Penny Evolution Elite® open fryers use innovative filtering and oil level technology to extend oil life, improve product quality and reduce overall oil consumption and costs. Here's how:

A smaller fry vat allows the same amount of product to be cooked in 40% less oil.\*

Sensor-activated Oil Guardian™ monitors oil level and automatically replenishes oil from a reservoir inside the fryer cabinet. This eliminates manual add backs and results in less frequent oil disposal.

Filtering is now easier and smarter than ever. Smart Touch Filtration™ lets you filter individual vats as needed while continuing to cook in other vats uninterrupted. Just touch a single button at the prompt to begin filtering. The system drains and filters oil, rinses away crumbs and returns

hot filtered oil to the vat in less than four minutes!† No handles, valves or anything else to pull, open or close.

Henny Penny Evolution Elite® series gas open fryers recover temperature very quickly and earn the ENERGY STAR® mark for energy efficiency.

iControl™ offers programmable operation plus a host of frying and oil management features.

Choose from 1, 2, 3, or 4-well, full or split vat configurations. Auto lift models and optional matching profile dump station available.

\*Based on throughput tests according to ASTM standards.

†4 minute filtration possible when following conditions are met:

- Ambient temperatures at or above 72° (22°C)
- Drain pan temperature at or above 160°F (71°C) at the beginning of the filtration cycle
- Filtration media that has been previously saturated with oil, but not overly saturated with impurities
- Filtration media is changed at the frequency recommended for your operation

## Standard Features

- Cooks the same size load in 40% less oil than standard 50 lb vat
- Oil Guardian™ automatic top off level sensors monitor oil level and add fresh oil as needed
- Smart Touch Filtration™
  - Tracks cook cycles and prompts to filter
  - Filter vats individually as needed
  - Touch one button to activate
  - No handles, valves or knobs
  - Rinse-wave action drains crumbs
  - Hot filtered oil returned, ready for drop in less than 4 minutes\*
- Heavy-duty stainless steel vats with 7-year warranty
- High-limit temperature protection
- Full vat, split vat or combination
- High-efficiency burners with solid state ignition
- Auto lift automatically lowers and raises basket (additional charge)
- Bulk oil dispose (additional charge)
- Heavy-duty basket rest removes easily for cleaning
- Stainless steel construction for easy-cleaning and long life
- 4 heavy-duty casters, 2 locking
- iControl™
  - 40 available cooking programs
  - Idle and melt modes
  - Load compensation
  - Proportional control
  - Filter tracking
  - Clean-out mode
  - Easy to switch language settings
  - USB support

## Accessories shipped with unit

- Fry baskets (additional charge)
  - 1 full basket per well
  - 2 half baskets per well
- 1 basket support for each vat
- Installation and operating manual

## Optional accessories

- FDS 210 fryer dump station with matching profile—can be attached
- ODS 300 50 lb oil disposal shuttle
- Fry well covers
- SmartFilter™ pads
- SmartFilter™ paper
- Oil dispensing jug

<input type="checkbox"/> APPROVED	<input type="checkbox"/> APPROVED AS NOTED	<input type="checkbox"/> RESUBMIT
AUTHORIZED SIGNATURE		DATE



PROJECT

ITEM NO

# Evolution Elite® Open Fryers

**EEG 241** 1-well gas  
**EEG 242** 2-well gas  
**EEG 243** 3-well gas  
**EEG 244** 4-well gas

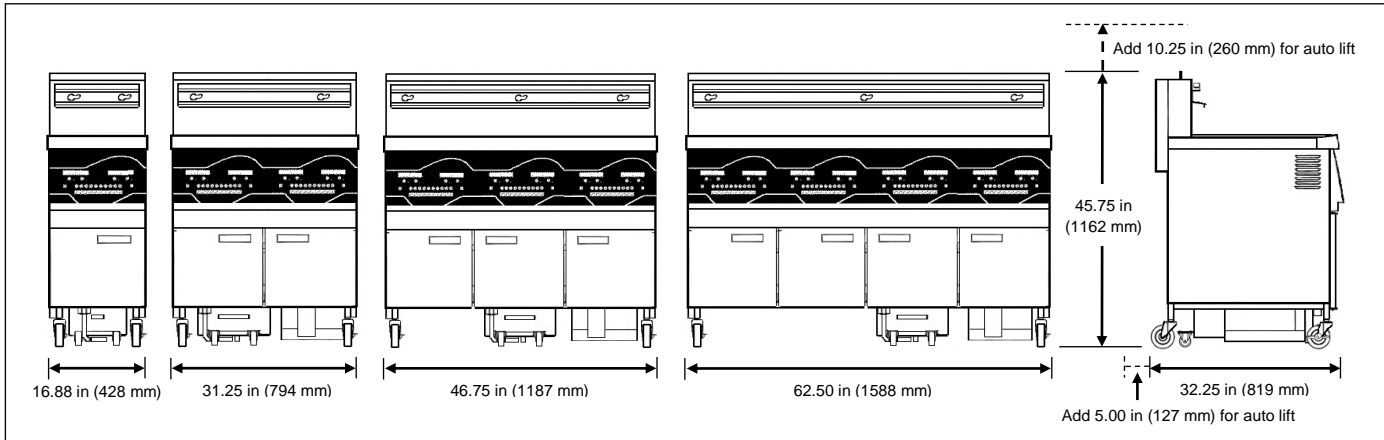

	EEG 241	EEG 242	EEG 243	EEG 244
--	---------	---------	---------	---------

### Dimensions

Width	16.88 in (428 mm)	31.25 in (794 mm)	46.75 in (1187 mm)	62.50 in (1588 mm)
Depth	32.25 in (819 mm)	32.25 in (819 mm)	32.25 in (819 mm)	32.25 in (819 mm)
Height	45.75 in (1162 mm)	45.75 in (1162 mm)	45.75 in (1162 mm)	45.75 in (1162 mm)

### Crated

Length	33 in (838 mm)	38 in (965 mm)	54 in (1372 mm)	68 in (1727 mm)
Depth	21 in (533 mm)	39 in (991 mm)	39 in (991 mm)	39 in (991 mm)
Height	52 in (1321 mm)	55 in (1397 mm)	55 in (1397 mm)	55 in (1397 mm)
Volume	21 ft³ (0.59 m³)	47 ft³ (1.4 m³)	67 ft³ (1.9 m³)	84 ft³ (2.4 m³)

### Weight

1 full	332 lb (151 kg)	N/A	N/A	N/A
1 split	N/A	N/A	N/A	N/A
2 full	N/A	501 lb (227 kg)	650 lb (295 kg)	N/A
2 split	N/A	532 lb (242 kg)	N/A	N/A
3 full	N/A	N/A	611 lb (277 kg)	811 lb (368 kg)
3 split	N/A	N/A	694 lb (315 kg)	N/A
4 full	N/A	N/A	N/A	795 lb (361 kg)
4 split	N/A	N/A	N/A	856 lb (388 kg)

### Heating natural gas or liquid petroleum

4 burners	8 burners	12 burners	16 burners
75,000 BTU/hr	150,000 BTU/hr	225,000 BTU/hr	300,000 BTU/hr
19.8 kW	39.6 kW	59.4 kW	79.2 kW
0.75 in gas line	0.75 in gas line	1.0 in gas line	1.0 in gas line

### Electrical

Volts	Phase	Hertz	kW	Amps	Wire
120	1	60	N/A	12.2	2+G
230	1	50	N/A	7.0	1NG

### Laboratory certifications



### Oil capacity

30 lb or 15 L per full vat

### Required clearances

Sides	6 in (152 mm) air flow
Back	6 in (152 mm) air flow, connections
Front	30 in (762 mm) remove filter pan
Top	11 in (280 mm) for auto lift

### Bidding specifications

Provide Henny Penny Evolution Elite® model EEG 241, 242, 243, or 244 reduced oil capacity gas open fryer designed to operate with 30 lb (14 kg) oil capacity per full vat. Unit may be ordered with full or split vat(s).

### Unit shall incorporate:

- Oil Guardian™ automatic oil top off system from jug-in-box or other reservoir in fryer cabinet
- Smart Touch Filtration™ integral touch activated filtering system that filters oil from one vat while cooking continues in other vats
- Oil drain pan with 4 casters and lock-in system with sensor warning when pan is not properly locked into place
- Unit qualifies for the ENERGY STAR® mark.
- Auto lift feature available at additional cost
- Fry vats of heavy duty stainless steel with 7-year warranty
- iControl™ with programmable operation, LED digital display, idle and melt modes, load compensation, proportional control, filtration tracking, clean-out mode, multiple language settings, and USB support
- 4 heavy-duty casters, 2 locking

Continuing product improvement may subject specifications to change without notice.

**24 Hour Technical Support:**  
 Henny Penny Technical Service  
 800 417.8405  
[technicalservices@hennypenny.com](mailto:technicalservices@hennypenny.com)

Henny Penny Corporation  
 PO Box 60 Eaton OH 45320 USA

+1 937 456.8400 800 417.8417  
 +1 937 456.8434 Fax 800 417.8434 Fax  
[www.hennypenny.com](http://www.hennypenny.com)

**HENNY PENNY**  
 Engineered to Last