



Electrolux

Modular Cooking Range Line 900XP One Well Gas Fryer 15 liter

ITEM # _____

MODEL # _____

NAME # _____

SIS # _____

AIA # _____



Electrolux



Modular Cooking Range Line 900XP One Well Gas Fryer 15 liter

391077 (E9FRGD1GF0) 15-lt gas fryer with 1 "V"
shaped well (external burners)
and 1 basket

Short Form Specification

Item No. _____

High efficiency 14 kW burners in stainless steel. Suitable for natural gas or LPG. Deep drawn V-shaped well. Oil drains through a tap into a container under the well. Height adjustable feet in stainless steel. Exterior panels in stainless steel. Worktop in 20/10, stainless steel. Right-angled side edges eliminate gaps and possible dirt traps between units.

Main Features

- Deep drawn V-Shaped well.
- High efficiency 14 kW burners in stainless steel with flame failure device attached to the outside of the well.
- Thermostatic regulation of oil temperature up to a maximum of 190 °C.
- Flame failure device on each burner.
- Overheat protection thermostat as standard on all units.
- Oil drains through a tap into a drainage container positioned under the well.
- All major compartments located in front of unit for ease of maintenance.
- Piezo spark ignition for added safety.
- IPX5 water resistance certification.
- The special design of the control knob system guarantees against water infiltration.
- Unit delivered with four 50 mm legs in stainless steel as standard (all round Stainless steel kick plates as option).
- Supplied as standard with 1 basket and 1 right side door for cupboard.

Construction

- Unit is 930 mm deep to give a larger working surface area.
- All exterior panels in Stainless Steel with Scotch Brite finishing.
- Model has right-angled side edges to allow flush fitting joints between units, eliminating gaps and possible dirt traps.
- Interior of well with rounded corners for ease of cleaning.

Included Accessories

- 1 of Door for open base cupboard PNC 206350
- 1 of Full size basket for 14 and 15lt free standing fryers PNC 921691

Optional Accessories

- Junction sealing kit PNC 206086
- Draught diverter PNC 206126
- Matching ring for flue condenser PNC 206127
- 4 wheels, 2 swivelling with brake (700/900XP). It is mandatory to install with base supports for feet/wheels. PNC 206135
- Flanged feet kit PNC 206136

APPROVAL: _____



Electrolux

Modular Cooking Range Line 900XP One Well Gas Fryer 15 liter

- Frontal kicking strip for concrete installation, 400mm PNC 206147
 - Frontal kicking strip for concrete installation, 800mm PNC 206148
 - Frontal kicking strip for concrete installation, 1000mm PNC 206150
 - Frontal kicking strip for concrete installation, 1200mm PNC 206151
 - Frontal kicking strip for concrete installation, 1600mm PNC 206152
 - 2 side kicking strips for concrete installation PNC 206157
 - Frontal kicking strip, 400mm (not for refr-freezer base) PNC 206175
 - Frontal kicking strip, 800mm (not for refr-freezer base) PNC 206176
 - Frontal kicking strip, 1000mm (not for refr-freezer base) PNC 206177
 - Frontal kicking strip, 1200mm (not for refr-freezer base) PNC 206178
 - Frontal kicking strip, 1600mm (not for refr-freezer base) PNC 206179
 - Pair of side kicking strips (not for refr-freezer base) PNC 206180
 - 2 panels for service duct for single installation PNC 206181
 - 2 panels for service duct for back to back installation PNC 206202
 - 4 feet for concrete installation PNC 206210
 - Sediment tray for 15lt fryers PNC 206235
 - Water coulmn with swivel arm (water column extension not included) PNC 206289
 - Chimney upstand, 400mm PNC 206303
 - Flue condenser for 1/2 module, 120 mm diameter PNC 206310
 - Door for open base cupboard PNC 206350
 - Base support for feet or wheels - 400mm (700/900XP) PNC 206366
 - Side handrail-right/left hand PNC 216044
 - Frontal handrail 400mm PNC 216046
 - Frontal handrail 800mm PNC 216047
 - Frontal handrail 1200mm PNC 216049
 - Frontal handrail 1600mm PNC 216050
 - 2 side covering panels for free standing appliances PNC 216134
 - Large handrail - portioning shelf, 400mm PNC 216185
 - Large handrail - portioning shelf, 800mm PNC 216186
 - Full size basket for 14 and 15lt free standing fryers PNC 921691
 - 2 half size baskets for 12, 14 and 15lt fryers PNC 921692
 - Filter for fryer oil collection basin for 7lt, 14lt, 15lt free standing fryers PNC 921693
 - Unclogging rod for 15lt drainage pipe PNC 921695
 - Deflector for floured products for 15lt fryers PNC 921696
- Pressure regulator for gas units PNC 927225



**Modular Cooking Range Line
900XP One Well Gas Fryer 15 liter**

The company reserves the right to make modifications to the products without prior notice. All information correct at time of printing.



Electrolux

Modular Cooking Range Line 900XP One Well Gas Fryer 15 liter

Front

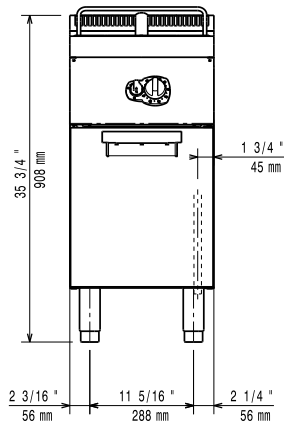

Top

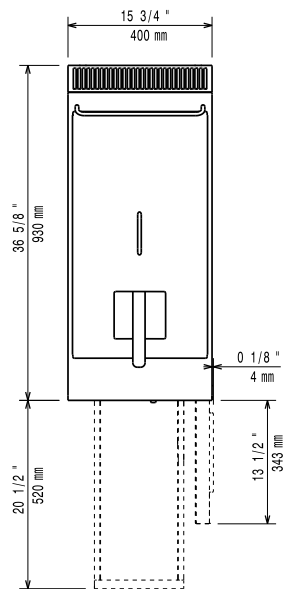

G = Gas connection

Side

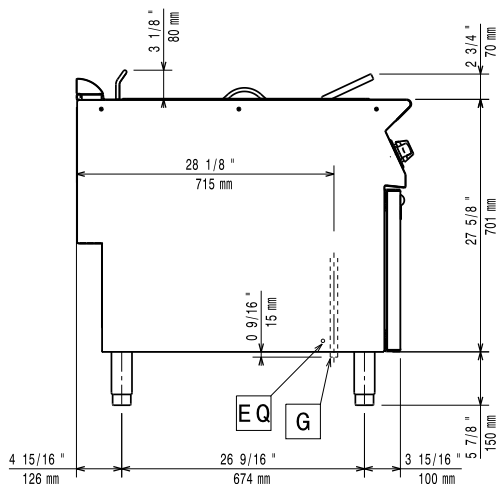

Gas

Gas Power:

391077 (E9FRGD1GF0) 47726 Btu/hr (14 kW)

Gas Type Option:

LPG

Gas Inlet:

1/2"

Natural gas - Pressure:

7" w.c. (17.4 mbar)

LPG Gas Pressure:

11" w.c. (27.7 mbar)

Key Information

Usable well dimensions (width):	240 mm
Usable well dimensions (height):	505 mm
Usable well dimensions (depth):	380 mm
Well capacity:	13 lt MIN; 15 lt MAX
Thermostat Range:	120 °C MIN; 190 °C MAX
Net weight:	50 kg
Shipping weight:	70 kg
Shipping height:	1080 mm
Shipping width:	460 mm
Shipping depth:	1020 mm
Shipping volume:	0.51 m ³

If appliance is set up or next to or against temperature sensitive furniture or similar, a safety gap of approximately 150 mm should be maintained or some form of heat insulation fitted.



**Modular Cooking Range Line
900XP One Well Gas Fryer 15 liter**

The company reserves the right to make modifications to the products without prior notice. All information correct at time of printing.