



Electrolux

Modular Cooking Range Line 900XP Two Wells Electric Fryer 15 liter

ITEM # _____

MODEL # _____

NAME # _____

SIS # _____

AIA # _____



Electrolux



Modular Cooking Range Line
900XP Two Wells Electric Fryer 15 liter

391088 (E9FREH2GF0) 15+15-lt electric fryer with 2
"V" shaped wells (external
heating elements) and 2
baskets

Short Form Specification

Item No. _____

High efficiency infrared heating elements (20kW) attached to the outside of the wells. Deep drawn V-Shaped wells. Oil drains through a tap into a container positioned under the wells. Height adjustable feet in stainless steel. Exterior panels in stainless steel. Worktop in 20/10, stainless steel. Right-angled side edges eliminate gaps and possible dirt traps between units.

Main Features

- Deep drawn V-Shaped wells.
- Interior of wells with seamlessly laser-welded corners for ease of cleaning.
- External infrared heating elements for ease of cleaning of internal well.
- Thermostatic regulation of oil temperature up to a maximum of 185 °C.
- Overheat protection thermostat as standard on all units.
- Oil drains through a tap into a drainage container positioned under the well.
- All major compartments located in front of unit for ease of maintenance.
- IPX5 water resistance certification.
- The special design of the control knob system guarantees against water infiltration.
- Unit delivered with four 50 mm legs in stainless steel as standard (all round Stainless steel kick plates as option).
- Supplied as standard with 2 baskets and 1 right and left side doors for cupboard.

Construction

- Unit is 930 mm deep to give a larger working surface area.
- All exterior panels in Stainless Steel with Scotch Brite finishing.
- Model has right-angled side edges to allow flush fitting joints between units, eliminating gaps and possible dirt traps.

Included Accessories

- 2 of Door for open base cupboard PNC 206350
- 2 of Full size basket for 14 and 15lt PNC 921691
free standing fryers

Optional Accessories

- Junction sealing kit PNC 206086
- 4 wheels, 2 swivelling with brake PNC 206135
(700/900XP). It is mandatory to install with base supports for feet/wheels.
- Flanged feet kit PNC 206136
- Frontal kicking strip for concrete PNC 206148
installation, 800mm
- Frontal kicking strip for concrete PNC 206150
installation, 1000mm
- Frontal kicking strip for concrete PNC 206151
installation, 1200mm
- Frontal kicking strip for concrete PNC 206152
installation, 1600mm

APPROVAL: _____



Electrolux

Modular Cooking Range Line 900XP Two Wells Electric Fryer 15 liter

- 2 side kicking strips for concrete installation PNC 206157
- Frontal kicking strip, 800mm (not for refr-freezer base) PNC 206176
- Frontal kicking strip, 1000mm (not for refr-freezer base) PNC 206177
- Frontal kicking strip, 1200mm (not for refr-freezer base) PNC 206178
- Frontal kicking strip, 1600mm (not for refr-freezer base) PNC 206179
- Pair of side kicking strips (not for refr-freezer base) PNC 206180
- 2 panels for service duct for single installation PNC 206181
- 2 panels for service duct for back to back installation PNC 206202
- 4 feet for concrete installation PNC 206210
- Sediment tray for 15lt fryers PNC 206235
- Water coulmn with swivel arm (water column extension not included) PNC 206289
- Oil drain pipe for 15lt free standing fryer PNC 206301
- Chimney upstand, 800mm PNC 206304
- Door for open base cupboard PNC 206350
- Base support for feet or wheels - 800mm (700/900) PNC 206367
- Side handrail-right/left hand PNC 216044
- Frontal handrail 800mm PNC 216047
- Frontal handrail 1200mm PNC 216049
- Frontal handrail 1600mm PNC 216050
- 2 side covering panels for free standing appliances PNC 216134
- Large handrail - portioning shelf, 400mm PNC 216185
- Large handrail - portioning shelf, 800mm PNC 216186
- Full size basket for 14 and 15lt free standing fryers PNC 921691
- 2 half size baskets for 12, 14 and 15lt fryers PNC 921692
- Filter for fryer oil collection basin for 7lt, 14lt, 15lt free standing fryers PNC 921693
- Unclogging rod for 15lt drainage pipe PNC 921695
- Deflector for floured products for 15lt fryers PNC 921696



**Modular Cooking Range Line
900XP Two Wells Electric Fryer 15 liter**

The company reserves the right to make modifications to the products without prior notice. All information correct at time of printing.

2014.06.26



Electrolux

Modular Cooking Range Line 900XP Two Wells Electric Fryer 15 liter

Front

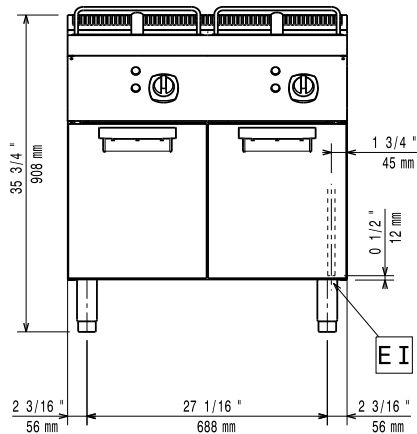

Top

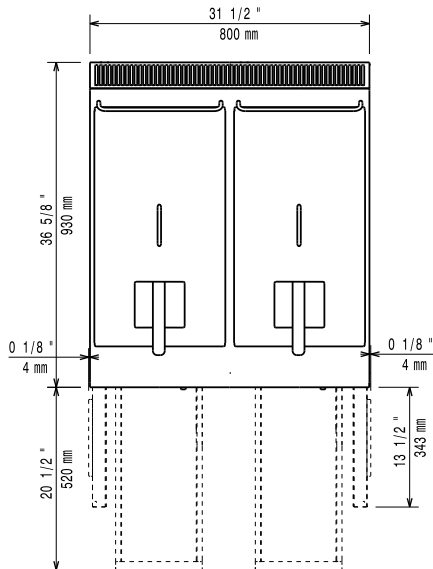

EI = Electrical connection

Side

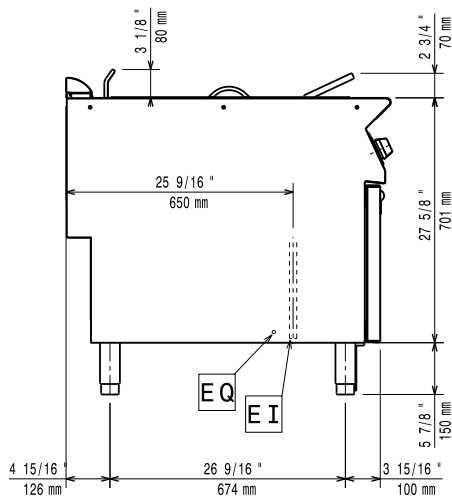

Electric

Supply voltage:

391088 (E9FREH2GF0) 400 V/3N ph/50/60 Hz

Total Watts:

20 kW

Key Information

Usable well dimensions (width):	240 mm
Usable well dimensions (height):	505 mm
Usable well dimensions (depth):	380 mm
Well capacity:	13 lt MIN; 15 lt MAX
Thermostat Range:	105 °C MIN; 185 °C MAX
Net weight:	86 kg
Shipping weight:	100 kg
Shipping height:	1080 mm
Shipping width:	1020 mm
Shipping depth:	860 mm
Shipping volume:	0.95 m ³

If appliance is set up or next to or against temperature sensitive furniture or similar, a safety gap of approximately 150 mm should be maintained or some form of heat insulation fitted.



Modular Cooking Range Line
900XP Two Wells Electric Fryer 15 liter

The company reserves the right to make modifications to the products without prior notice. All information correct at time of printing.