

# Washer extractor

## W555H

### Features and benefits

- **Compass Pro<sup>®</sup> microprocessor offers:**
  - Large display and one control knob for easy program selection
  - Language selection
  - Quick selection and option buttons for the most frequently used wash programs and options
  - Wash program packages optimized on Economy, Performance and Time. (Available on general programs)
- **AS – Automatic Savings:**
  - The machine weighs the linen and adjusts the amount of water and energy according to the load. This leads to considerable savings in case the machine is not fully loaded. (Available on general programs)
- Extremely low water and energy consumption – see table below
- Four compartment detergent box for manual dosing of powder or liquid detergent
- High extraction force for efficient dewatering
- Door with gasket and strong hinges built for heavy duty operation
- Stainless and galvanized steel in all vital parts for high degree of rust protection
- **Power Balance:**
  - Maximises the extraction force, leading to highest dewatering and savings in drying
  - Minimizes the stress on the machine, leading to trouble-free operation and increased machine lifetime
  - Reduces vibrations, making it possible to install the machine in all locations



Images shown are a representation of the product only and variations may occur.

### Main options

- Automatic liquid detergent supply (optional I/O board)
- Connection to booking- /payment- system or coin meter
- Drain pump
- Stacking kit to install tumble dryer T5130 on top to save space

Main specifications			W555H	
Max. capacity	filling factor 1:9	kg/lb	6/13	
Drum,	volume	litre	53	
	diameter	ø mm	452	
Extraction		rpm	1450	
G-factor			530	
Heating alternatives, 230/400V	electricity	kW	2.2 / 2.8 / 4.4	
	non-heated		x	
<b>Consumption data "Normal 60°C"</b>				
<b>Economy*</b>			Full load, 6 kg	Half load, 3 kg**
Total time		min	49	46
Water consumption (cold+hot)		litre	38+10	18+5
Energy consumption (motor/heating/hot water)		kWh	0.2/0.2/0.6	0.2/0.1/0.3
Residual moisture		%	46	48
* Water temperature 15°C cold water and 65°C hot water.				
** Programs with AS.				

Electrical connections*					
Heating alternative	Main voltage		Heating power kW	Total power kW	Recommended fuse A
	Hz	Hz			
Electric heated	220-230V 1-	50/60	2.1	2.5	16
	220-230V 1-	50/60	4.2	4.7	25
	240V 1-	50/60	2.2	2.6	16
	240V 1-	50/60	4.4	4.8	20
	220-230V 3 -	50/60	4.2	4.7	20
	240V 3 -	50/60	4.4	4.8	20
	380-400V 3 -	50/60	3.2	3.6	10
	415V 3 -	50/60	3.6	4.0	10
	440V 3 -	60	4.0	4.5	16
	480V 3 -	60	4.4	4.8	16
	380-400V 3N -	50/60	4.2	4.7	10
	415V 3N -	50/60	4.4	4.8	10
	Non heated	220-240V 1 -	50/60	-	0.9

Water connections		W555H
Water valves	DN	20
Water pressure	kPa	200-500
Capacity at 300 kPa	l/min	17
Drain valve	ø mm	50
Draining capacity	l/min	160
Liquid detergent supplies		5
Floor requirements		
Frequency of the dynamic force	Hz	24.2
Floor load at max extraction	kN	1.02 ± 0.3
Sound levels		
Sound power level (IEC 60704-2-4)		
wash	dB(A)	59
extraction	dB(A)	72
Heat emission		
% of installed power, max		5
Shipping data**		
Shipping volume	net, kg crated, m <sup>3</sup>	100 0.46
Accessories		
Stainless steel fluff collector		x
Stacking kit with tumble dryer		x
Steel base		x
Dimensions in mm		
A1	Width	595
A2	Width	735
B	Depth	974
C	Height	832
D		306
E		641
F		84
G		194
H		48
I		65
J		78
K		120
L		119
M		501
N		681
O		764
1	Operating panel	5 Hot water
2	Detergent box	6 Drain valve
3	Door opening ø 255 mm	7 Drain pump
4	Cold water	8 Electrical connection
		9 Payment system

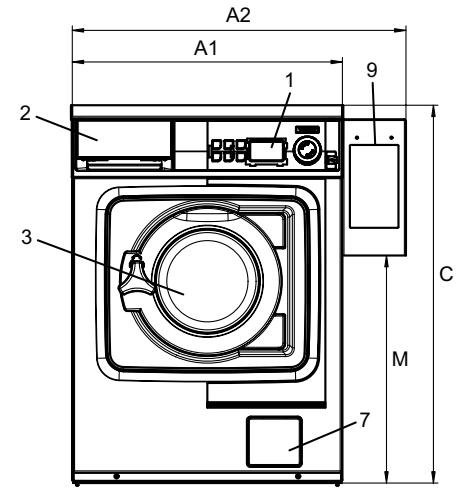

Front

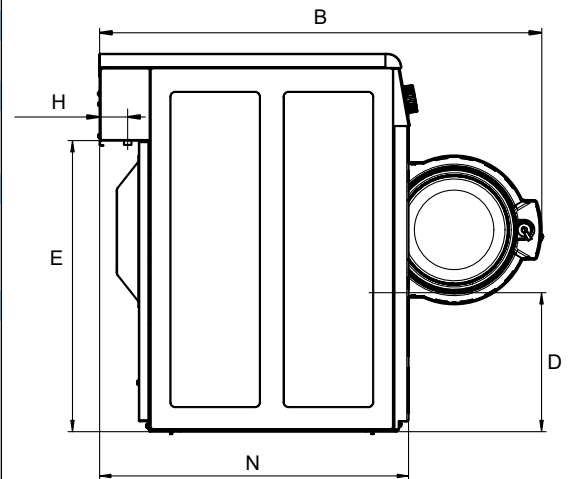

Side view

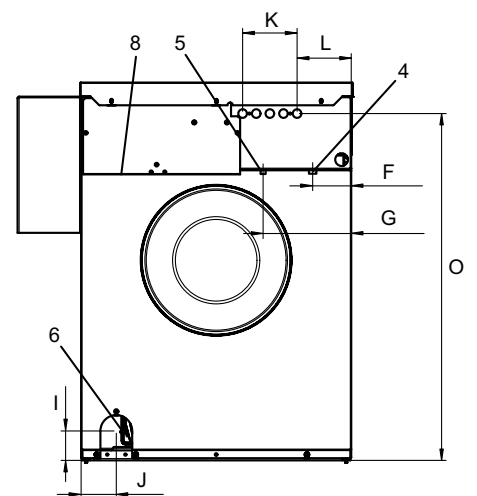

Rear

Front and side panels in light grey and blue (RAL 260 70 05, 250 60 30)

\* Other voltages available, see installation manual.

\*\* Average data. Crated weight/shipping volume depends on configuration. Please contact logistics for exact measures.