

EX3

User Manual



► CONTENTS

CONTENTS	2
MANUAL REVISIONS	5
NOTIFICATIONS	6
· Explanation of descriptions	6
GENERAL INFORMATION	7
· Introduction	7
· General instructions	7
· Intended use	8
· Warnings and Precautions	8
TRANSPORT	11
· Packaging	11
· Delivery inspection	11
STORAGE AND DISPOSAL	12
· Long-term storage requirements	12
· Machine disposal requirements	12
· Caution	12
TECHNICAL SPECIFICATIONS	13
· EX3 1GR MINI & 2GR MINI machine data	13
· EX3 1GR MINI & 2GR MINI versions accessories	13
· EX3 1GR MINI & 2GR MINI versions front view	14
· EX3 1GR MINI & 2GR MINI versions bottom view	14
· EX3 1GR MINI & 2GR MINI versions external dimensions	15
· EX3 2GR machine data	16
· EX3 2GR versions accessories	16
· EX3 2GR versions front view	17
· EX3 2GR versions bottom view	17
· EX3 2GR versions external dimensions	18
BUTTONS AND CONTROLS	19
· Machine controls	19
INSTALLATION AND START UP	20
· Machine positioning	20
· Mains water connection	21

► CONTENTS

· Water filter requirements	21
· Boiler pressure and temperature information	22
· Drain connection checklist	22
· Electrical connection checklist	23
· Initial starting procedure	24
· Machine handling tips	24
OPERATION	25
· Inserting the portafilter in the group	25
· Espresso brewing	25
· Steaming and frothing milk	26
· Dispensing hot water - Automatic hot water control	26
· Dispensing hot water - Manual hot water control	26
CLEANING AND CARE	27
· Cleaning reminders	27
· Daily cleaning – At the end of each working day be sure to:	27
· Daily flushing - Control version	27
· Daily flushing - Display version	28
· Weekly cleaning or Periodical cleaning and care – Once per week be sure to:	28
· Weekly cleaning with espresso machine detergent per week be sure to:	28
USER PROGRAMMING - CONTROL VERSIONS	29
· Additional button functions	29
· Programming the coffee dosage	29
USER PROGRAMMING - DISPLAY PID VERSIONS	30
· Programming the coffee / tea dosage	30
· User menu – Access & browsing	30
· User menu – Settings summary chart	30
· t0 – Boiler temperature	31
· cro – Enabling / Disabling Chrono setting	31
· Pi1 – Pi2 – Pi3 – Enabling / Disabling preinfusion on each group	31
· Eco – ‘Eco mode’ timing setting	31
· Std – ‘Eco mode stand-by’ timing setting	32
· SLc – Service liter counter	32
· ScC – Service coffee counter	32
· tot – Total counters	33
· cLo – Clock setting	33
· AUt – Auto On/Off setting	33

▶ CONTENTS

MACHINE ALERTS	34
· Alarms and warnings	34
TROUBLESHOOTING	35
· Machine faults	35
· Brewing faults	35
· Limescale faults	35

▶ MANUAL REVISIONS

Rev. #:	Date:	TSB#:	Change Description
01	Oct. 08, 2019	None	First draft released for technical review and validation testing.
02	Oct. 30, 2019	None	Modify layout, add programming instructions.
03	Dec. 03, 2019	None	Revise instructions based on Service Dept input.
04	Dec. 06, 2019	None	Add contact information.
05	Feb. 05, 2020	None	Add display PID programming instructions (rev1.04).
06	Apr. 03, 2020	None	Add EX3 Mini Technical Specifications.

► NOTIFICATIONS

· Explanation of descriptions

There are five different levels of notification intensity within this manual, as identified by the signal terms: DANGER, WARNING, IMPORTANT, NOTE and PRO TIP. The level of risk and importance of the notification is determined by the following definitions. Always observe the warnings to ensure safety and prevent potential injury and product damage.



Important:

Alerts against unsafe practices. Observe Important notifications to ensure food safety, prevent possible minor personal injury, or damage to the machine.



WARNING:

Indicates a potentially hazardous situation which, if the WARNING is ignored, could result in serious injury or even death.



DANGER:

INDICATES AN IMMINENTLY HAZARDOUS SITUATION WHICH, IF NOT AVOIDED, WILL LIKELY RESULT IN SERIOUS INJURY AND EVEN DEATH.



Note:

Gives additional information which may be helpful during the operation, routine maintenance, and cleaning of the machine.



Pro Tip:

Gives helpful hints and suggestions from the manufacturer that take the guesswork out of choosing settings and care intervals.

► GENERAL INFORMATION

· Introduction

Thank you for choosing an EX3 espresso machine. We hope you enjoy it !

- Please read this user manual carefully before using the machine.
- This manual contains important instructions regarding safe intended use of the machine.
- Do not discard this manual, it will be useful for future reference. If damaged or lost, request a new copy from the manufacturer/ distributor or download a free PDF copy via:
www.creminternational.com/downloads

· General instructions

Note: The manufacturer is not liable for damage to persons or property resulting from failure to follow the instructions, warnings and precautions listed in this manual when installing and using this machine.

- Machine installation and certain maintenance operations should only be performed by qualified service personnel.
- All safety instructions and warnings contained in this manual should be observed at all times to ensure safe installation, use, and maintenance.
- Do not attempt to remove covers or safety shields to access the interior of this machine or make repairs. Repairs should be made by an authorised technician or service centre.
- Owners are liable for ensuring that users have been properly trained to operate the machine and understand the potential risks involved.
- The owner or installer will be liable for all non-authorized modification of the machine. Non-authorized alteration or modification of the machine will immediately void the manufacturer's warranty.
- This manual references the machine at the time of sale. The commercial availability of subsequent versions including modifications, upgrades or adaptations does not oblige the manufacturer to apply any changes to this machine, nor is it obliged to update the documentation supplied.
- The manufacturer reserves the right to withdraw currently available manuals whenever deemed appropriate and reasonable.
- Periodically, some updates and changes may be required for this machine. In this event, a technician will be responsible for ensuring the change is made in accord with manufacturer's specifications.

► GENERAL INFORMATION

· Intended use

- The coffee machine has been designed and manufactured to make espresso coffee and other hot drinks (e.g., steaming and frothing milk). Do not use it for any other purpose.
- The machine is intended to be used by trained personnel for preparing foodstuffs.
- This machine is not intended for use in industrial kitchens, domestic kitchens, or similar locations.
- The manufacturer will not be held liable for damage to persons or property due to incorrect, improper or negligent use by nonprofessional personnel.
- The A-weighted sound pressure level is below 70 dB.
- To ensure optimal performance, install the machine in a location where these parameters will not be exceeded:
 - Maximum inlet water pressure: 0.9MPa (9 Bar), or 1.0MPa (10 Bar) [only for Norway, Sweden and Denmark]
 - Minimum inlet water pressure: 0.0MPa (0 Bar)

Note: For a suitable performance of machine, maximum inlet water pressure should be kept between 0.8-0.9MPa. Install a pressure reducer in case water pressure exceeds this range.

- Maximum inlet water temperature: 40°C
- Ambient temperature between +10°C (min.) and +40°C (max.).

· Warnings and Precautions

- Install the machine in a horizontal position and away from heat sources and flammable objects.
- Appliance is only to be installed in locations where its use and maintenance is restricted to trained personnel. Access to the service area is restricted to persons having knowledge and practical experience of the appliance, in particular as far as safety and hygiene are concerned.
- This machine should only be installed on a water-resistant work surface that is capable of adequately supporting the machine's weight.

► GENERAL INFORMATION

· Warnings and Precautions

- The appliance is not suitable for installation in an area where a water jet could be used. This appliance must not be cleaned with a water jet or a pressure washer.
- The appliance is not suitable for outdoor use, where it would be exposed to severe weather or extreme temperatures.
- The instructions for appliances connected to the water mains by detachable hose-sets shall state that the new hose-sets supplied with the appliance are to be used and that old hose-sets should not be reused.
- Use the inlet hose included with the machine to connect it to the water mains in accordance with the national rules applicable in the country where machine is installed.
- Plug the machine into a properly installed, earth grounded electrical outlet with line voltage that matches the specifications for the machine.
- For appliances not fitted with a supply cord and a plug, means for disconnection must be incorporated in the fixed wiring in accordance with the wiring rules.
- Ensure that the power supply voltage does not fluctuate by more than 6%.
- Position the power cable so that users cannot trip over it. Keep the power cable away from sharp edges and heat sources.
- Do not remove or disable any of the mechanical, electrical, or thermal protection safety equipment.
- If supply cord is damaged, it must be replaced by the manufacturer, its service agent or similarly qualified persons in order to avoid a hazard.
- In case of emergency, (e.g., the machine catches fire or becomes unusually hot or noisy), disconnect the power immediately and turn off the water supply.
- If the machine is not going to be used for an extended period of time, disconnect the power. When disconnecting the power, pull the plug rather than the cable.
- Keep all hazardous packaging materials, such as plastic bags, styrofoam, and staples, out of reach of children.
- Before performing maintenance and/or moving the machine, disconnect the machine from the power supply and wait for it to cool down.
- To ensure fault-free machine operation, only use manufacturer-approved replacement parts and accessories.

► GENERAL INFORMATION

· Warnings and Precautions

- When packed for storage, store the machine in a dry place with an ambient temperature above 5°C. Boxes may be stacked up to three units high of the same model. Do not place other heavy items on top of the box.
- If the machine is likely to be exposed to temperatures below 0°C during handling and transport, make sure that service personnel empty the boiler and water system. (The machine's boiler and water system are empty when delivered from the factory.)
- Never immerse the machine, plug or power cable in water, as there is a risk of electric shock.
- Place the machine out of reach of children.
- This appliance is not intended for use by persons (including children) with reduced physical, sensory or mental capabilities, or lack of experience and knowledge, unless they have been given supervision or instruction concerning use of the appliance by a person responsible for their safety.

Note: safety regulation not valid for Europe.

- **Specific safety regulation for Europe:**
This appliance can be used by children aged from 8 years and above and persons with reduced physical, sensory or mental capabilities or lack of experience and knowledge if they have been given supervision or instruction concerning use of the appliance in a safe way and understand the hazards involved. Children shall not play with the appliance. Cleaning and user maintenance shall not be made by children without supervision.
- Do not use the machine if the power cable or plug is damaged, or the machine has been dropped. Contact a service technician for repairs or to ensure that it is safe for use.
- Do not place any liquids on the machine.
- Do not touch the machine's hot surfaces or dispensing equipment.
- Do not touch the machine if your hands or feet are wet.
- Do not operate the machine if any part except the dispensing equipment is wet.
- Do not block the vents with rags or other objects.
- Do not insert foreign objects into the vents.
- Check the drain regularly to make sure that waste water is emptying properly.

► TRANSPORT

· Packaging

- The machine is shipped in a custom-designed carton which utilizes model-specific polystyrene cushions to protect it from damage.
- The machine's carton features standardized handling symbols to explain proper shipping and storage methods.
- The machine must remain in a horizontal position during the transport. Do not store or handle the machine except on its feet.
- During transport protect the carton and machine from impact drops, crushing, shocks, moisture and exposure to extreme temperature.

· Delivery inspection

- Upon receipt and delivery ensure that the machine is in the exact condition described in the enclosed documentation, and that all accessories are included. Missing items should be reported to the manufacturer or dealer immediately.
- Damage caused during transport should be reported to the shipping agent and the machine's distributor immediately.
- Packaging materials are potentially dangerous and should be kept away from children.
- The carton and all packing materials are recyclable and should be returned to a recycling centre for disposal.

► STORAGE AND DISPOSAL

· Long-term storage requirements

Before storage for a month or more be sure to:

- Perform all weekly and periodic cleaning procedures described in this manual.
- Disconnect and roll up the power cord (this should be performed by a qualified person).
- Disconnect the machine's water inlet hose from the domestic water supply and drain the boilers (this should be performed by a qualified person).
- Clean the drip tray and exterior of the machine to remove any coffee or other residue.
- Cover / re-pack the machine in its original carton and store it in a dry place where it will not be exposed to extreme temperatures or humidity.
- When returning the machine to service after long-term storage, perform all weekly and periodic cleaning procedures and reconnect the water and power supplies (this should be performed by a qualified person) before use.

· Machine disposal requirements

If the machine ever needs to be scrapped and disposed of be sure to:

- Disconnect and roll up the power cord (this should be performed by a qualified person).
- Disconnect the machine's water inlet hose from the domestic water supply and drain the boilers (this should be performed by a qualified person).
- Pack up and ship/deliver the machine to a certified recycling centre.



· Caution

- Risk of fire and electric shock.
- Replace only with manufacturer's original cord set.
- Disconnect from power supply before servicing.

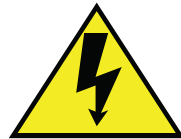







► TECHNICAL SPECIFICATIONS

· EX3 1GR MINI & 2GR MINI machine data

Version:	EX3 1GR MINI Control	EX3 1GR MINI Display PID	EX3 2GR MINI Control	EX3 2GR MINI Display PID
Temperature control system:	Pressure switch	Temperature PID controller	Pressure switch	Temperature PID controller
Dispensing control system:	Push button control	Push button control with group display	Push button control	Push button control with group display
Steam wand:	1 unit		1 unit (standard), 2 units (option)	
Hot water outlet:	1 unit			
Boiler system:	1 steam boiler			
Boiler operating pressure:	0.8 to 1.2 bar			
Steam boiler volume:	6L			
Power rating:	220V-240V 1N~ 2800W 50-60Hz			
Water connection:	3/8" Internal thread BSPP			
Height, width, depth:	465, 550, 575mm			
Machine weight:	48 Kg		50 Kg	
Ambient noise:	< 70 db			

· EX3 1GR MINI & 2GR MINI versions accessories

Item:	2-spout portafilter	1-spout portafilter	55-cm inlet hose	Blind filter	Drain tube (150 cm)	Power cable	Drinks grids (TA versions only)
							
Quantity:	1 unit	1 unit	1 unit	1 unit	1 unit	1 unit	1 or 2 units

► TECHNICAL SPECIFICATIONS

· EX3 1GR MINI & 2GR MINI versions front view

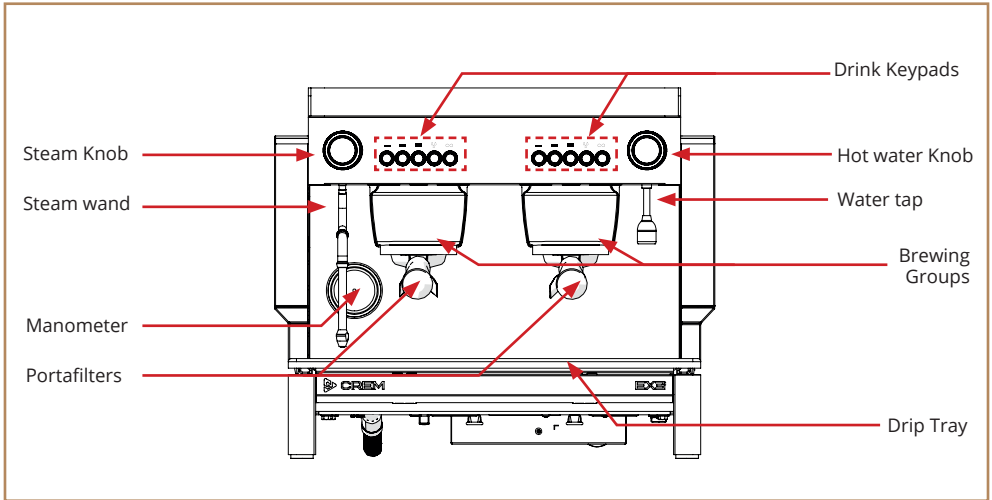

· EX3 1GR MINI & 2GR MINI versions bottom view

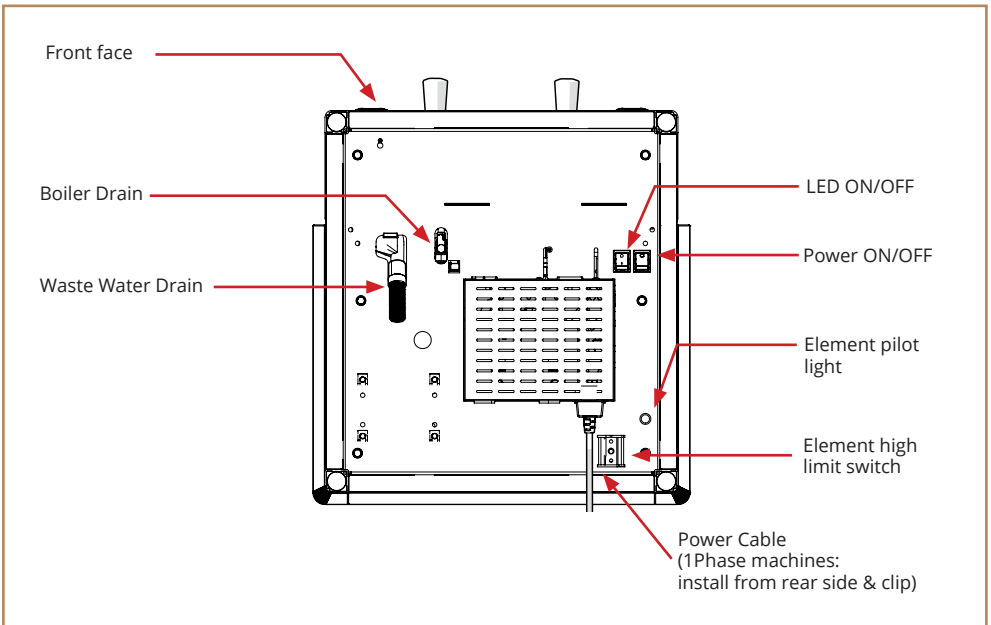

► TECHNICAL SPECIFICATIONS

· EX3 1GR MINI & 2GR MINI versions external dimensions

Standard

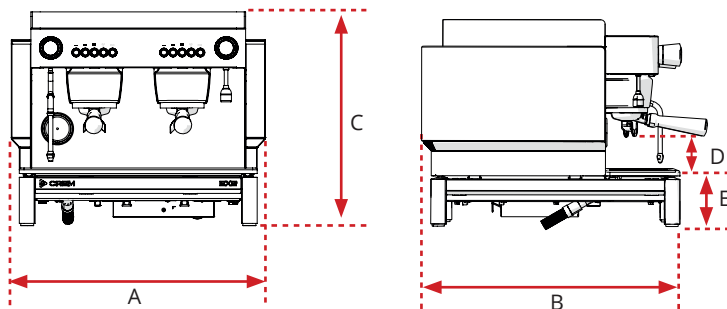

Dimension	Standard
A	550mm
B	575mm
C	465mm
D	74mm
E	125mm

Takeaway

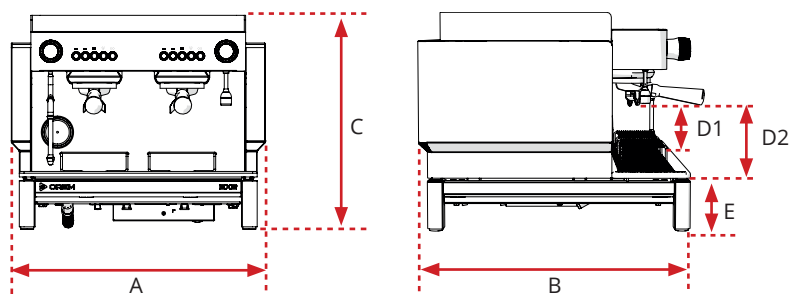







Dimension	Takeaway
A	550mm
B	575mm
C	465mm
D1	84mm
D2	124mm
E	125mm

► TECHNICAL SPECIFICATIONS

· EX3 2GR machine data

Version:	EX3 2GR Control	EX3 2GR Display PID
Temperature control system:	Pressure switch	Temperature PID controller
Dispensing control system:	Push button control	Push button control with group display
Steam wand:	1 unit (standard), 2 units (option)	
Hot water outlet:	1 unit	
Boiler system:	1 steam boiler (single boiler version)	
Boiler operating pressure:	0.8 to 1.2 bar	
Steam boiler volume:	11.5L	
Power rating:	220V-240V 1N~ 3100W 50-60Hz	
Water connection:	3/8" Internal thread BSPP	
Height, width, depth:	465, 770, 575mm	
Machine weight:	Single boiler version = 60 Kg	
Ambient noise:	< 70 db	

· EX3 2GR versions accessories

	2-spout portafilter	1-spout portafilter	55-cm inlet hose	Blind filter	Drain tube (150 cm)	Power cable	Drinks grids (TA versions only)
Item:							
Quantity:	1 unit	1 unit	1 unit	1 unit	1 unit	1 unit	2 units

► TECHNICAL SPECIFICATIONS

· EX3 2GR versions front view

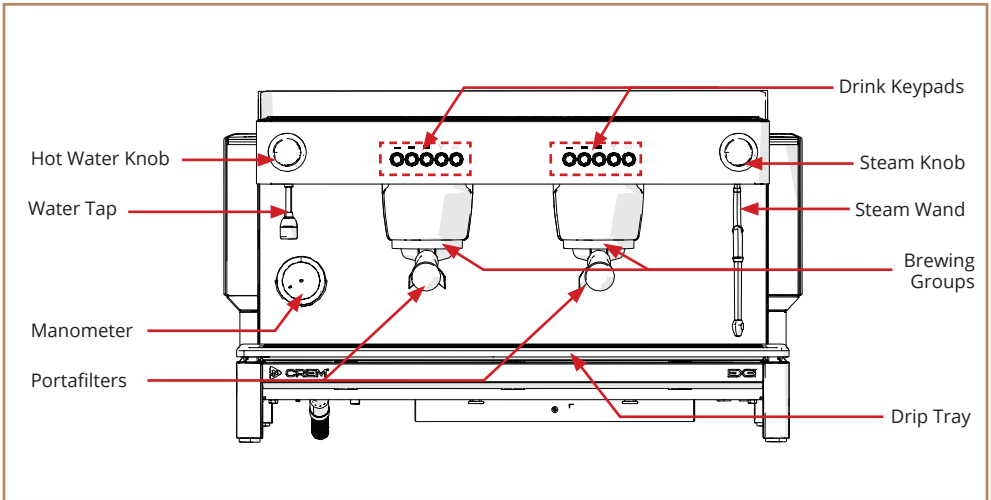

· EX3 2GR versions bottom view

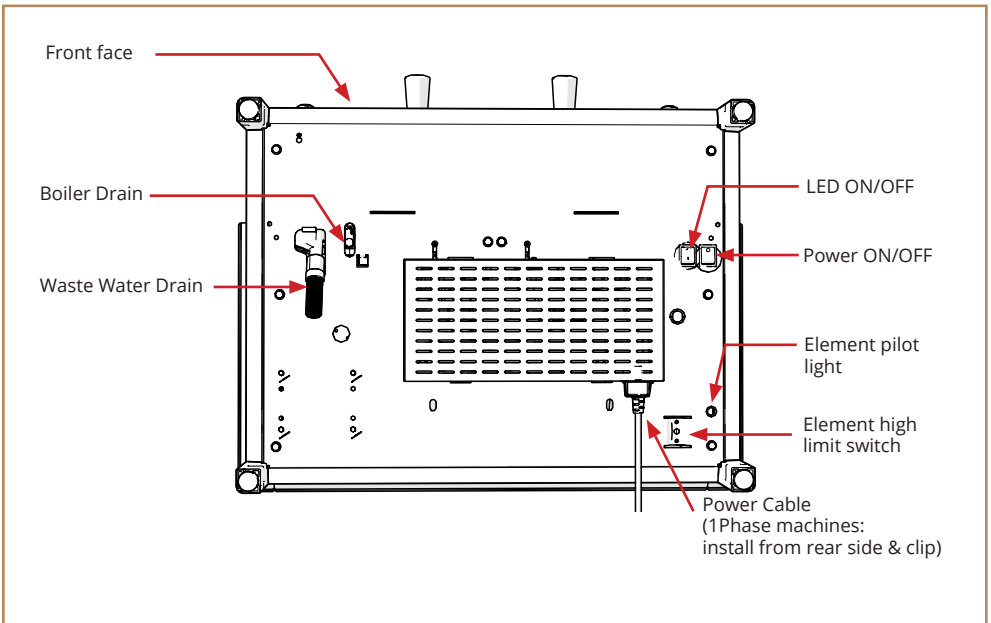

► TECHNICAL SPECIFICATIONS

· EX3 2GR versions external dimensions

Standard

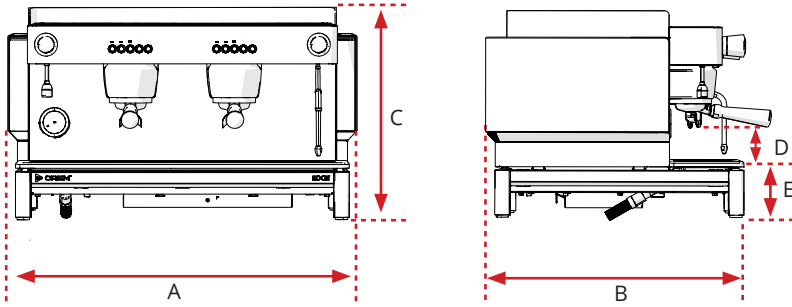

Dimension	Standard
A	770mm
B	575mm
C	465mm
D	74mm
E	125mm

Takeaway

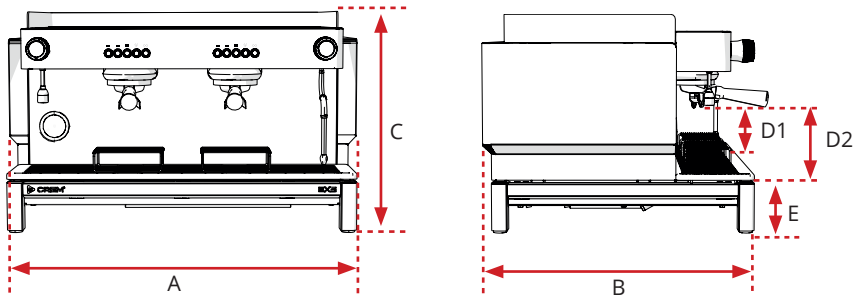

Dimension	Takeaway
A	770mm
B	575mm
C	465mm
D1	84mm
D2	124mm
E	125mm

► BUTTONS AND CONTROLS

· Machine controls

EX3 features a push button control block for each brewing group. Control functions are explained below.

Versions with display (PID) are equipped with an individual 3 digit display on each group for monitoring machine status, performing user programming and machine adjustments.

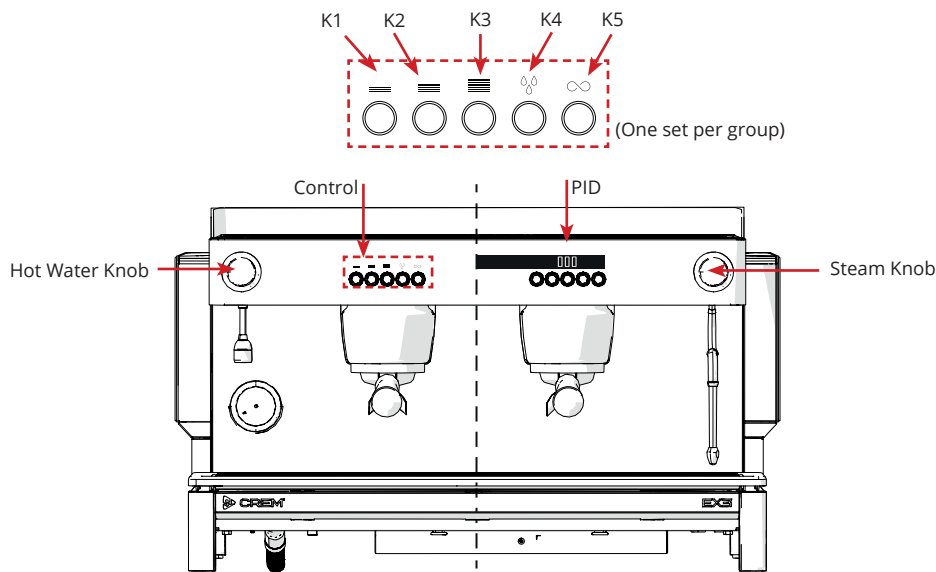

Button	Selection description	Programming menu function
K1	Short espresso	(+)
K2	Medium espresso	(-)
K3	Long espresso	
K4	Group flush	
K5	Continuous / Hot water	Enter / Accept



Pro Tip:

All group buttons are fully adjustable via the user programming. See the Dose Programming section for more details.



Pro Tip:

Versions with display will show the shot timer during the brewing process.

► INSTALLATION AND START UP

· Machine positioning

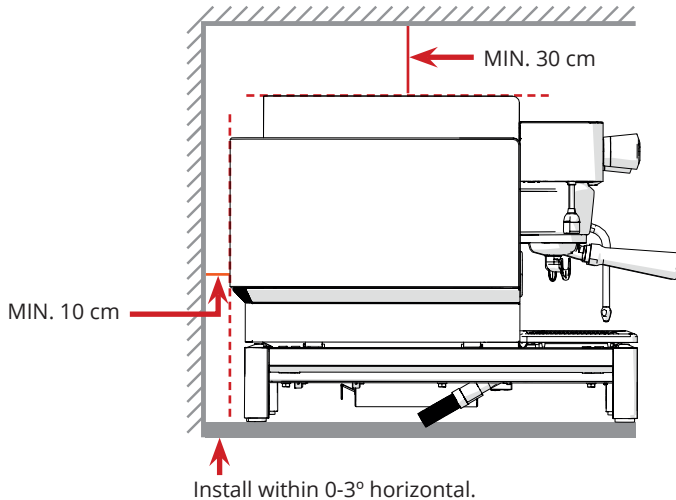

1. Installing the machine in the service area must be performed by a qualified person. As the machine may be quite heavy, at least two strong, capable individuals are recommended to work together to lift and position the machine. Consult the Technical Specifications page for the specific machine model being installed for machine weight and dimensions details. Contact a service technician to do this task if you are not confident about performing the steps below.
2. Position the machine on a level, sturdy, and water-resistant surface approximately 110cm above floor level for ease of access and usage.
3. Adjust the feet to ensure that it dispenses coffee evenly to all cups.
4. Ensure enough free space is available above (>30cm) and behind (>10cm) the machine to ensure easy cleaning and maintenance and adequate ventilation.



Important:

Leave an air gap of at least 30cm above the machine and 10cm behind it to ensure adequate ventilation. The machine must be installed within 3° of horizontally level front-to-back and side-to-side to ensure proper hydraulic function and drainage. Confirm with a spirit level or digital angle gauge.

Do not install the machine if the machine or installation surface it is wet. Allow it to dry completely and ask a service technician to ensure that none of the electrical components have been affected.

► INSTALLATION AND START UP

· Mains water connection

1. Connecting the machine to the domestic water supply must be performed by a qualified person. Contact a service technician to do this task you are not confident about performing the steps below.
2. Purge at least 20 liters of water from the domestic water supply before connecting the machine to it to flush out any debris that may be in the plumbing system that would otherwise accumulate inside the boilers.
3. The domestic plumbing system should be fitted with a brass 3/8" NPT male pipe fitting and an in-line shut-off valve. Connect the 180cm water inlet hose included with the machine to the domestic water supply and tighten the line fittings with a wrench to 15 ft. lbs. / 20N-m.



Important:

Use the inlet hose included with the machine to connect it to the water mains in accordance with the national rules applicable in the country where machine is installed. Never reuse damaged hoses



Important:

To prevent limescale build up in the boiler and other components, a water-softening system must be installed in-line ahead of the machine. Read more on section for water filter requirements.

· Water filter requirements

Only use safe drinking water with a hardness rating between 5°fH and 8°fH (French hardness degrees). If the hardness value is below this limit, corrosion of hydraulic components is likely. If the value is higher, lime-scaling inside the boiler will occur. In both cases, the proper function of the machine and quality and taste of the coffee will be negatively affected.

If drinking water is not within the ratings shown above, a water filter must be installed inline ahead of the espresso machine. Failure to install a water filter will result in voiding of the warranty and any damage resulting from limescale buildup will be the responsibility of the owner.

Filtration device

1. Ensure that a water filtration device or system is installed in-line in the domestic water supply ahead the machine to prevent contamination inside the machine's hydraulic system. Contact a service technician to do this task if you are not confident about performing the steps below.
2. Open the water tap and allow the filter to fill (if new/previously unused). Then the machine's steam boiler will begin to fill. Check carefully around the service area for leaks or drips. If leaks/drips are detected turn off the tap immediately and check/tighten any leaking fittings.
3. If necessary, connect the machine to a water softener to reduce water hardness using the flexible 55cm hose included in the accessory box.



Important:

Always maintain the water filtration device or system in accordance with the manufacture's specifications. Failure to routinely maintain the filtration device or system will result in limescale build-up inside the machine's hydraulic system which will eventually result in machine failure. Please read more under the cleaning and care section.

► INSTALLATION AND START UP

· Boiler pressure and temperature information

Boiler pressure is directly controlled by water temperature. The steam boiler's optimal temperature operating range is from 116-120°C for milk steaming and brewing results.

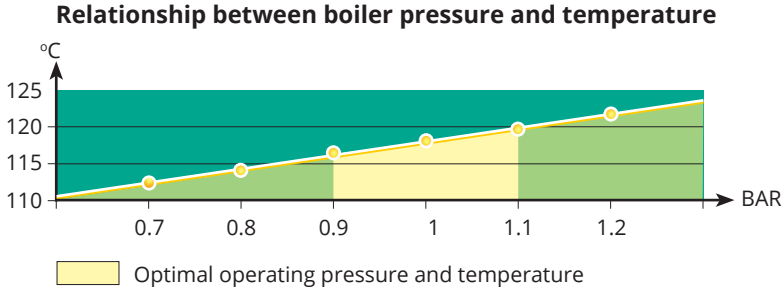

Pro Tip:

Significantly exceeding this operating range will result in excessive steam, high energy usage, and milk scorching. Setting the temperature too low will result in poor coffee extraction, slow group boiler heating, and low/no steam.

· Drain connection checklist

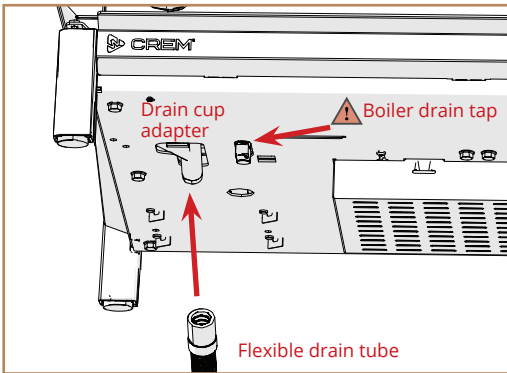

1. Connect one end of the flexible drain tube to the drain cup outlet by inserting it through the access hole in the panel mounted in the bottom of the chassis. (It is located under the drip tray and grill. Contact a service technician to do this task you are unsure how to access this area of the machine.)
2. Connect the other end of the drain tube to the domestic plumbing drainage system in the service area.
3. Replace/reinstall the drip tray and grill.



Pro Tip:

Ensure that the drainage tube is not twisted and that it is below the level of the drain cup to prevent trapping water and other residue in the tube which could mold or produce bad smells.



WARNING!

Never open the boiler drainage tap while the machine is in operation! Close position = Right side
The pressurised hot water could cause scalding or serious injury. Emptying the boiler must be performed by qualified personnel.

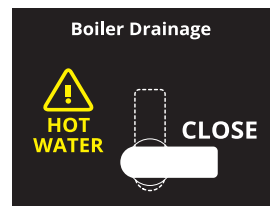

► INSTALLATION AND START UP

· Electrical connection checklist



DANGER!

If the mains cable or plug is damaged, it must be replaced by the manufacturer, its service agent or similarly qualified persons in order to avoid a hazard.



Important:

The manufacturer will not be held liable for damage to persons, animals or property resulting from incorrect installation of the coffee machine.

1. The machine should only be connected to the power supply by qualified personnel. The following safety instructions should be obeyed at all times.
2. Ensure that the electrical requirements stated on the TECHNICAL SPECIFICATIONS and on the ratings plate located under the drip tray inside the machine match the specifications of the power supply.
3. Ensure that the domestic electrical supply where the machine is being installed is rated for and able to provide the power required by the machine. Insufficient power supply, wiring, grounding, or insulation can result in overheating and possibility of fire.
4. The coffee machine must be connected to an earth grounded electrical outlet that complies with the regulations in force in the country of installation. For appliances not fitted with a supply cord and a plug, means for disconnection must be incorporated in the fixed wiring in accordance with the wiring rules.
5. Ensure that a circuit breaker engineered for the power consumption of the machine is installed to protect the electrical supply, as specified on the ratings plate located under the drip tray.
6. Never connect the machine to the power supply via extension cords, plug adapters, or shared outlets.

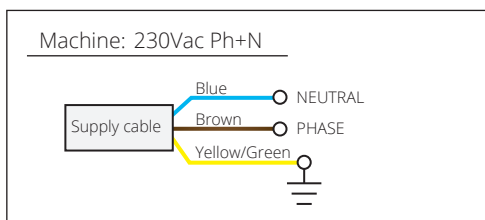

► INSTALLATION AND START UP

· Initial starting procedure



Note:

Remove all protective film during installation before powering the machine ON for the first time. This will prevent the film melting/becoming stuck due to high temperature when the machine is heating up. This step is especially critical for all machine with E-Cup heating system installed.

Before using the machine be sure to:

1. Ensure the machine's domestic water supply is opened at the tap.
2. Turn on the main power switch and wait a few minutes for the boiler to heat up.
3. Confirm that the heating lamp is illuminated while the boiler is heating.
4. While the machine is heating up, run a drink cycle through each group to bleed air out of the group boilers and to ensure they are working.
5. Open the steam knobs/taps to ensure they are working.
6. When the boiler reaches the working pressure / temperature, the heating lamp will turn off. Wait extra 10 minutes to allow all hydraulic components to reach and stabilize into correct temperature

The machine is now ready to use.

· Machine handling tips

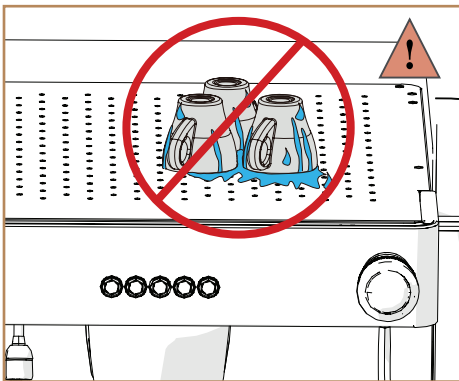

WARNING!

Allowing water to drip into the machine can cause mechanical and electrical damage.

Do not place wet cups directly on the cup shelf. Always thoroughly dry any cups before storing them on the warming shelf.

► OPERATION

· Inserting the portafilter in the group

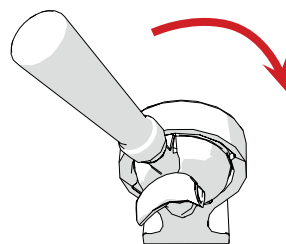
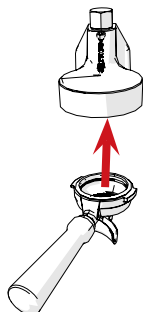

- Align the portafilter's two flanges with the two slots in the group housing.
- Insert the portafilter and rotate it counterclockwise until the handle is approximately perpendicular to the face of the coffee machine.

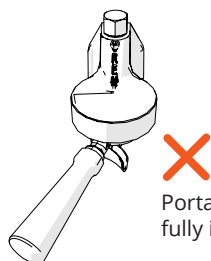

Portafilter is not fully inserted.



Installed correctly.

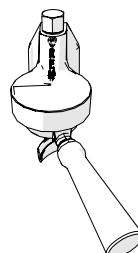

Group gasket is worn out and needs to be replaced.

· Espresso brewing

1. Unlock and remove the portafilter from the group head.
2. Fill the filter basket with espresso-grind coffee (approx. 7g for single or 14g for a double espresso).
3. Compact the coffee.
4. Insert the filled portafilter into the group head and lock it into the correct position.
5. Place the cup(s) under the portafilter.
6. Select the desired option from the drink button to begin brewing.



WARNING!

Never try to open the portafilter while the machine is in operation! The pressurised hot water could cause scalding or serious injury. After dispensing has finished, wait at least 3 seconds before removing the portafilter.



Pro Tip:

When not in use store the portafilter inserted in the group to keep it warm. This is important to maintain optimal brewing temperature while the espresso is dispensing.

▶ OPERATION

· Steaming and frothing milk

1. Place the steam wand over the drip tray and open the steam knob/handle for a few seconds to allow condensed water to be ejected. Close the steam knob/handle when only steam is coming out.
2. Immerse the steam wand into the milk, making sure the wand tip is submerged. Open the steam knob/handle again to begin steaming or frothing the milk. Always keep the tip of the steam wand submerged in the milk while steaming!
3. Once the milk reaches the desired temperature, close the knob/handle and wait for the steaming to stop, then remove the pitcher.
4. After steaming/frothing is finished, position the steam wand over the drip tray and open the steam knob/handle again for a few seconds to purge any milk remaining in the wand. Then wipe down the outside of the steam wand with a damp cloth to prevent nozzle blockage and to keep it clean.

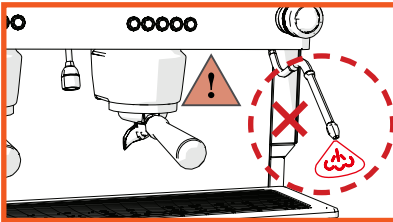

WARNING!

Do not remove the pitcher or allow the steam wand to extend out of the milk while steaming/frothing, it may cause serious burns and injuries.

· Dispensing hot water - Automatic hot water control



WARNING!

Never place hands and fingers directly under the hot water outlet during dispensing to avoid scalding or serious burns.

1. Place a pitcher (or other heat resistant vessel) under the hot water outlet.
2. Press the desired hot water button to begin dispensing.
3. Hot water dispensing will stop automatically after the programmed dispensing time is reached, or press the button again to stop it manually any time before it finishes.

· Dispensing hot water - Manual hot water control



WARNING!

Never place hands and fingers directly under the hot water outlet during dispensing to avoid scalding or serious burns.

1. Place a pitcher (or other heat resistant vessel) under the hot water outlet.
2. Rotate the knob counter clock wise, to begin dispensing
3. Rotate the knob clock wise, to stop dispensing hot water

► CLEANING AND CARE

· Cleaning reminders

- To keep the machine looking and working like new, always follow all the cleaning and care instructions provided in this manual.
- For safety always turn the machine off at the main power switch when cleaning the exterior surfaces.
- All exterior surfaces should be cleaned with a damp, lint-free cloth that will not scratch the machine, glass surfaces can be cleaned with a streak-free glass cleaner and a dry cloth.
- Do not use aggressive cleaning detergents, solvents or degreasers. These may damage the plastic and rubber parts, and will leave unwanted residue

· Daily cleaning – At the end of each working day be sure to:

Steam and hot water

1. Position the steam wand over the drip tray and open the steam tap for one minute to fully flush the wand. Repeat for each steam wand.
2. Clean the steam wand and the water tap. Be sure that the nozzles are not clogged or partially blocked with milk or other residue. If it's necessary to remove them for cleaning, be careful not to deform or damage any of the components during removal.

Group head and portafilters

1. Clean the shower plate and the group gasket with a soft brush to remove coffee residue.
2. Run the flushing cycle for each group at the end of each day to prevent coffee residue drying and building up inside the brewing groups.

Drip tray & bodyworks

1. Clean the external surfaces of the machine, paying special attention to the glass and stainless steel parts to remove any coffee residue and smudges and fingerprints.
2. Clean the drip tray and the stainless steel insert grid under running water.

· Daily flushing - Control version

1. Remove the filter basket and place the blind filter in the portafilter.
2. To activate the cleaning program:
 - a.) Turn off the machine at the main switch.
 - b.) Press and hold down the K3 on the control panel of the group requiring cleaning. Without releasing the button, turn on the machine. Auto-cleaning cycle will start automatically.
 - c.) Release the button. The machine will flush and rinse itself.
3. After rinsing, remove the blind filter and store it in a safe place for the next usage. Reinstall the filter basket in the portafilter.
4. Clean the internal side of the portafilter before replacing the espresso filter. If needed, let the portafilter soak into warm water or use cleaning detergent for espresso machines.

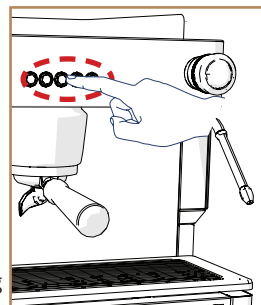

WARNING!

Do not open the group or remove the portafilter until the cleaning has finished! This will release steam and hot water which could result in burns.



Pro Tip:

Run the flushing cycle for each group at the end of each day to prevent coffee residue drying and building up inside the brewing groups.

► CLEANING AND CARE

· Daily flushing - Display version

1. Remove the filter basket and place the blind filter in the portafilter.
2. To activate the cleaning program:
 - a.) While the machine is on, press and hold down the K5 on the control panel of the group requiring cleaning and then push K1 at the same time. Auto-cleaning cycle will start automatically and display show **[CLE]**
 - b.) Release the buttons. The machine will clean, flush, and rinse itself.
3. After rinsing, remove the blind filter and store it in a safe place for the next usage. Reinstall the filter basket in the portafilter.
4. Clean the internal side of the portafilter before replacing the espresso filter. If needed, let the portafilter soak into warm water or use cleaning detergent for espresso machines.

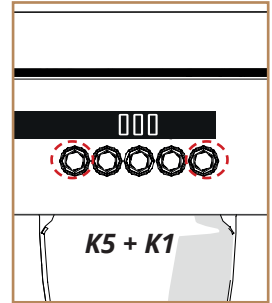

WARNING!

Do not open the group or remove the portafilter until the cleaning has finished! This will release steam and hot water which could result in burns.



Pro Tip:

Run the flushing cycle for each group at the end of each day to prevent coffee residue drying and building up inside the brewing groups.

· Weekly cleaning or Periodical cleaning and care – Once per week be sure to:

Group head

1. Run the cleaning cycle for each group at the end of each week to thoroughly clean the group head, shower plate and portafilter to ensure great coffee taste. See Weekly cleaning with espresso machine detergent section for details.

Drain hose

1. If the drain hose is installed, clean the drain cup by slowly pouring one liter of warm water into it to dissolve and remove any build-up of coffee residue that often accumulates inside the drain cup and tube.

· Weekly cleaning with espresso machine detergent per week be sure to:

1. Once a week, add espresso detergent in the blind filter when running the daily flushing.
2. After cleaning, with detergent, the group needs to be flushed. So run the Automatic cleaning cycle two more times to flush out any remaining detergent. Repeat for each group, then remove the blind filter and store it in a safe place for the next usage.



WARNING!

Do not open the group or remove the portafilter until the cleaning has finished! This will release steam and hot water which could result in burns.







Pro Tip:

Run the cleaning cycle for each group at the end of each week to thoroughly clean the group head, shower plate and portafilter to ensure great coffee taste.

► USER PROGRAMMING - CONTROL VERSIONS

· Additional button functions

To activate these functions, turn off the machine at the power switch then, while holding down the required button on the left-side drinks button bank, turn the machine back on.

-  Short Espresso (K1): Enable / Disable electronic pre-infusion.
-  Medium Esp. (K2): Enable / Disable automatic hot water function on Continuous button.
-  Long Espresso (K3): Start auto-cleaning.
-  Group Flush (K4): Turn on/off flashing of button lights.

· Programming the coffee dosage

This section explains how to program the doses dispensed automatically by the drink buttons.



Important:

Use a portafilter filled with fresh coffee for every new dose you program.

- On machines not equipped with a display, hold down the Continuous Dispensing (K5) button for 8 seconds. The Continuous Dispensing (K5) button light will flash.
- Press the dispensing option that you wish to program: Short Espresso (K1), Medium Espresso (K2) and Long Espresso (K3). The light on the button pressed and on the Continuous Dispensing button will remain on.
- The group will start dispensing coffee. When the desired volume is reached in the cup, press the selected button again to stop dispensing. This volume setting will be saved.
- Repeat this process for all of the dispensing options that you wish to reprogram.

If you only need to reprogram one of the dispensing options, follow the steps above and program just that option. All of the other dispensing options will remain unchanged (default settings).



Note:

- Programming any of the options on the left-hand Drink buttons (when viewing the machine from the front) automatically sets the dispensing volumes on all of the other Drink buttons. This only applies to the left-hand Drink buttons. Programming other Drink buttons only modifies the option selected.
- Group flush button (K4) can be programmed as a standard drink if desired.

► USER PROGRAMMING - DISPLAY PID VERSIONS

· Programming the coffee / tea dosage

This section explains how to program the doses dispensed automatically by the drink buttons.



Important:

Use a portafilter filled with fresh coffee for every new dose you program.

On machines equipped with a display:

1. Hold down K5 for 8 seconds, until **[SEL]** message is shown on the display and K5 flashes.
2. Press the dispensing option that you wish to program: Short Espresso (K1), Medium Espresso (K2), Long Espresso (K3) and Flush (K4). The light on the button pressed and K5 button will remain on. The group will start dispensing coffee.
3. When the desired volume is reached in the cup, press the selected button again to stop dispensing. This volume setting will be saved.

Repeat this process for all the dispensing options that you wish to reprogram.

If you only need to reprogram one of the dispensing options, follow the steps above and program just that option. All the other dispensing options will remain unchanged (default settings).

To come back to home screen, wait 30 seconds or turn the machine off and on again.



Note:

- Programming any of the options on the left-hand Drink buttons (when viewing the machine from the front) automatically sets the dispensing volumes on all of the other Drink buttons. This only applies to the left-hand Drink buttons. Programming other Drink buttons only modifies the option selected.
- Group flush button (K4) can be programmed as an standard drink if desired.
- If K5 is enabled as Tea button, the automatic hot water dosage can be programmed by time on K5. This dosage will be independent on each group.

· User menu – Access & browsing

To access the user programming settings, follow the steps below:

1. Hold down K5 for 8 seconds, until **[SEL]** message is shown on the display and K5 flashes. (Programming dosages)
2. Hold down K5 for 8 seconds again, until **[t0]** (1st menu setting) is shown on the display.
3. Browse through the menu by pressing K1 & K2.
4. Access to each setting by pressing K5. The adjustable parameter will flash. Accept and save by pressing K5 again.
5. To exit from the menu, browse to **[ESc]** (Escape) and press K5.

· User menu – Settings summary chart

Setting	Description
[t0]	Boiler temperature
[cro]	Chrono setting (shot timer)
[PiX]*	Preinfusion (Gr1, Gr2 & Gr3)
[Eco]*	Eco mode timer
[Std]*	Eco mode stand-by timer

Setting	Description
[SLc]	Service liter counter (water filter)
[ScC]	Service coffee counter (maintenance)
[tot]	Total counters
[cLo]	Clock settings
[AUt]*	Auto on/off function

* Disabled by default on service menu

► USER PROGRAMMING - DISPLAY PID VERSIONS

· **t0** – Boiler temperature

To change the machine's boiler temperature, follow the steps below:

1. Enter the user programming and browse through the menu (see previous instructions).
2. When **[t0]** is shown on the display, enter by pressing K5.
3. Select with K1 and K2 the boiler temperature.
4. Accept and save setting by pressing K5. You are back in the user programming menu.

· **cro** – Enabling / Disabling Chrono setting

To change the chrono setting, follow the steps below:

1. Enter the user programming and browse through the menu (see previous instructions).
2. When **[cro]** is shown on the display, enter by pressing K5.
3. Use K1 and K2 to enable **[on]** or disable **[off]** the chrono setting.
4. Accept and save setting by pressing K5. You are back in the user programming menu.

· **Pi1 – Pi2 – Pi3** – Enabling / Disabling preinfusion on each group

To enable or disable the electronic preinfusion function individually on each group, follow the steps below:

1. Enter the user programming and browse through the menu (see previous instructions).
2. When **[Pi1]** (for group 1), **[Pi2]** or **[Pi3]** is shown on the display, enter by pressing K5.
3. Use K1 and K2 to enable **[on]** or disable **[off]** the preinfusion setting individually on each group **[Pi1]**, **[Pi2]** or **[Pi3]**.
4. Accept and save setting by pressing K5. You are back in the user programming menu.



Note:

Electronic preinfusion setting is disabled by default on the Service menu. The reason for this is because the group head has a preinfusion chamber built in. However, for coffee roasts which need even more preinfusion time, this electronic function can be enabled to achieve maximum extraction. During preinfusion, the coffee will be dosed for pre-programmed number of seconds, then the pressure will be released for a pre-programmed number of seconds, known as pausing, then the brew will begin again and run until the brewing is completed.

· **Eco** – 'Eco mode' timing setting

To adjust the Eco mode timer, follow the steps below:

1. Enter the user programming and browse through the menu (see previous instructions).
2. When **[Eco]** is shown on the display, enter by pressing K5.
3. Select with K1 and K2 the Eco mode timer, from **[off]** (Disabled) up to **[024]** hours.
4. Accept and save setting by pressing K5. You are back in the user programming menu.



Note:

- The ECO mode allows the machine to reduce its electrical demand by lowering the boiler temperature to 105°C/221°F (default setting) after X hours of nonuse. Message **[Eco]** will be shown on the group 1 display. To 'wake up' the machine, the user simply needs to press any button. Then it will start heating up to normal operating temperature and will be ready for use within just a few minutes.
- ECO mode settings are disabled by default on the Service menu.

► USER PROGRAMMING - DISPLAY PID VERSIONS

· Std – ‘Eco mode stand-by’ timing setting

To adjust the Eco mode stand-by timer, follow the steps below:

1. Enter the user programming and browse through the menu (see previous instructions).
2. When **[Std]** is shown on the display, enter by pressing K5.
3. Select with K1 and K2 the Eco mode stand-by timer, from **[oFF]** (Disabled) up to **[024]** hours.
4. Accept and save setting by pressing K5. You are back in the user programming menu.



Note:

- The ECO mode stand-by disconnects the boiler element after X hours of nonuse. Message **[oFF]** will be shown on the group 1 display. To ‘wake up’ the machine, the user simply needs to press any button.
- If both, **[Eco]** and **[Std]** are set up, the timer for Std will be at least 1h higher than the Eco timer.
- ECO mode settings are disabled by default on the Service menu.

· SLc – Service liter counter

To consult the partial Service liter counter, follow the steps below:

1. Enter the user programming and browse through the menu (see previous instructions).
2. When **[SLc]** is shown on the display, enter by pressing K5.
3. The counter will be shown in the 3 digits display by changing between thousands (with a dot) and units in the following format: **[000. - 000]**. Eg. 1200 liters: **[001. - 200]**.
4. Accept by pressing K5. You are back in the user programming menu.



Note:

- Service liter counter setting is adjusted on the Service menu. It is disabled by default, so the partial counter will show 0 by default.
- Alarm **[FiL]** will be shown on the display when the partial counter reaches the set value to inform that the external water filter must be replaced. To reset the partial Service liter counter, consult ‘Messages & Alarms’ section of this manual.

· Scc – Service coffee counter

To consult the Service coffee counter, follow the steps below:

1. Enter the user programming and browse through the menu (see previous instructions).
2. When **[Scc]** is shown on the display, enter by pressing K5.
3. The counter will be shown in the 3 digits display by changing between thousands (with a dot) and units in the following format: **[000. - 000]**. Eg. 12500 coffees: **[012. - 500]**.
4. Accept by pressing K5. You are back in the user programming menu.



Note:

- Service coffee counter setting is adjusted on the Service menu. It is disabled by default, so the partial counter will show 0 by default.
- Alarm **[SEr]** will be shown on the display when the partial counter reaches the set value to inform that the periodic maintenance must be executed. To reset the partial Service coffee counter, consult ‘Messages & Alarms’ section of this manual.

► USER PROGRAMMING - DISPLAY PID VERSIONS

· **tot** – Total counters

To consult the Total counters, follow the steps below:

1. Enter the user programming and browse through the menu (see previous instructions).
2. When **[tot]** is shown on the display, enter by pressing K5.
3. The counters will be shown in the 3 digits display by changing between thousands (with a dot) and units in the following format: **[000. - 000]**.
4. Browse through the counter by pressing K5. They will follow this order:
[tot] Total coffee counter -> K5 -> **[000. - 000]** -> K5 -> **[Gr1]**
[Gr1] Group 1 coffee counter -> K5 -> **[000. - 000]** -> K5 -> **[Gr2]**
[Gr2] Group 2 coffee counter -> K5 -> **[000. - 000]** -> K5 -> **[Gr3]**
[Gr3] Group 3 coffee counter -> K5 -> **[000. - 000]** -> K5 -> **[tEA]**
[tEA] Automatic tea counter -> K5 -> **[000. - 000]** -> K5 -> **[Lit]**
[Lit] Total liter counter **[000. - 000]** -> K5 -> **[tot]**
5. Accept by pressing K5. You are back in the user programming menu.



Note:

- All selections add +1 to the counters.
- Every brewing shot below 5 seconds won't be accounted

· **cLo** – Clock setting

To change the Clock setting, follow the steps below:

1. Enter the user programming and browse through the menu (see previous instructions).
2. When **[cLo]** is shown on the display, enter by pressing K5.
3. Select with K1 and K2 the clock settings.
4. Browse and set the clock following this format:
Hour **[00h]** -> K5 -> Minutes **[00M]** -> Week day **[00X]**.
Weekdays: **[001]** Monday; **[002]** Tuesday; ... ; **[007]** Sunday
5. Accept and save setting by pressing K5. You are back in the user programming menu.

· **AUt** – Auto On/Off setting

To change the Auto On/Off setting, follow the steps below:

1. Enter the user programming and browse through the menu (see previous instructions).
2. When **[AUt]** is shown on the display, enter by pressing K5.
3. Select with K1 and K2 the Auto On/Off settings.
4. Browse and set the auto on/off following this format:
On time **[on]** -> K5 -> On Hour **[00h]** -> K5 -> On Minutes **[00M]** -> K5 ->
Off time **[oFF]** -> K5 -> Off Hour **[00h]** -> K5 -> Off Minutes **[00M]**
5. Accept and save setting by pressing K5. You are back in the user programming menu.



Note:

Auto On/Off setting is disabled by default on the Service menu.

► MACHINE ALERTS

· Alarms and warnings

To alert users that routine service of the machine is due or against a situation that could possibly cause damage to the machine, EX3 has the following alerts programmed into its software:

Display versions

Display Code	Machine status	Alarm Name	Warning / Alarm	Solution
[AL1]	Machine blocked and all touchpads buttons blink	NTC is short-circuited	Alarm	Call a service specialist to replace it
[AL2]	Machine blocked and all touchpads buttons blink	NTC is not connected	Alarm	Call a service specialist to replace it
[AL3]	Selected button blinks and brew must be stopped manually	No flow detected on this group	Warning	Call a service specialist
[FiL]	Machine blocked and all touchpads buttons blink	Steam Boiler FillingUp timeout	Alarm	Turn the main switch off and on again. Check that the machine is receiving water
[Eco]	Touchpads lights off Boiler temperature is decreased to 105°C	Eco mode status	Warning	Press any button from K1 to K4 to 'wake up' the machine
[oFF]	Touchpads lights off Boiler element disconnected	Stand-by mode status	Warning	Press any button from K1 to K4 to 'wake up' the machine
[SEr]	Machine works Static message on group 1	Service maintenance alarm	Warning	Call service specialist to perform maintenance routine. To reset the service alarm counter: - Keep pressed K1+K2 and turn the machine on by the main switch. - Message [rSE] will be shown on Group 1
[FiL]	Machine works Static message on group 1	Water filter maintenance alarm	Warning	Call service specialist to perform maintenance routine. To reset the service alarm: - Keep pressed K3+K4 and turn the machine on by the main switch. - Message [rFi] will be shown on Group 1

► TROUBLESHOOTING

· Machine faults

Problem	Possible cause	Solution
The machine does not start up when turned on	The plug is not correctly inserted into the power socket	Check that the plug is correctly inserted and that the power socket is operational.
	The circuit breaker and/or differential are disconnected.	Check that they are connected.
	Check that they are connected	Call service personnel to replace them.
The steam wand does not dispense steam	The steam wand is clogged with dried milk.	Clean the wand and, if necessary, remove the nozzle and unclog it using a pin or needle.
The group boiler does not heat water	Standby mode is activated.	Press again K1+K5 to exit Standby mode.
Preinfusion is not working	When the preinfusion mode is "enabled" you must program the ON/OFF settings of this function.	Set up the preinfusion settings as explained in "User Programming > Preinfusion settings"
Water is found underneath the machine	The drain tube is blocked with used grounds/rubbish or is pulled off the drain cup.	Clean the drainage tube.

· Brewing faults

Problem	Possible cause	Solution
Coffee dispensing is too fast:	The coffee grind is too coarse.	Switch to a finer grind of espresso.
Coffee dispensing is too slow:	The coffee grind is too fine.	Switch to a coarser grind of espresso.

· Limescale faults

Problem	Possible cause	Solution
Coffee dispensing temperature is too cold:	Heat-exchanger outlet pipes are clogged with limescale.	Turn of the machine at the switch and contact a technician to make needed repairs.
Brewing groups do not dispensing water:	Water system is clogged with limescale.	Turn of the machine at the switch and contact a technician to make needed repairs.

For the warranty to be valid the conditions for maintenance must have been followed according to our instructions, proper precaution has been made and warranty claim been issued without delay.

The affected equipment may not be used during awaiting service if there is any risk that the damage or defect would worsen.

The warranty will not cover consumption supplies such as glassware, normal maintenance such as cleaning of filters, contaminations in water, lime, incorrect voltages, pressure or adjustment of water amounts.

The warranty will not cover damages of defects caused by incorrect handling and operation of the appliance.

**For service
Please contact your dealer**

Your Dealer

Crem International (Shanghai) Co., Ltd
Building 5, No.521-551, Kangyi Road, Pudong New Area, Shanghai 201315, China.

Crem International Spain S.L.U.
C/ Comerç nº 4 - Pol. Ind. Alcodar, 46701 - Gandía (Valencia - Spain)



www.creminternational.com