

Parrilla GMB 100



FEATURES

Precision and strength is key to the PARRILLA by MIBRASA®. Effortlessly regulate the height of your grill surface thanks to the carefully engineered pulley cable and counterweight system, keeping maintenance down to a minimum.

The system lets us sear, cook and rest our ingredients, to get the optimal result every time.

ERGONOMICALLY DESIGNED WITH MAXIMUM QUALITY AND SECURITY

With a sloping grill, the grease runs down the weld-free grill bars to prevent grease build-up. Grease drips down to the collector with an easy to remove mechanism ready to clean.

The base is lined with refractory bricks to ensure maximum heat efficiency and resistance to pure fire. And the built-in cooling system in outer case guarantees a maximum level of security.

Built using quality steels providing strength and durability; ergonomically designed for practicality and ease of use, each feature plays a crucial part in delivering the ultimate grilling machine for every chef.

TECHNICAL INFORMATION

| | |
|-------------------------------------|------------------------------------|
| Fire up time ¹ | 30 min-average |
| Cooking temperature | 250 °C |
| Total cooking surface area | 635mm x 890mm = 0.57m ² |
| Initial charcoal load ¹ | 15 kg |
| Grill height range | 350 mm |
| Charcoal load duration ² | 7 h |
| Equivalent power* | 4.5 kW |
| Exhaust rate | 4100 m ³ /h |
| Net weight ³ | 265 kg |
| Crated weight | 383 kg |
| Crated size (WxDxH) | 1120 x 1310 x 1380 mm |

*Approximate data

1. Consult instruction manual

2. Will vary depending on quality of charcoal

3. Weight with accessories included

INCLUDED ACCESSORIES

- Rod grill [CPV100]
- Ember poker [PK]
- Ash shovel [PALA]
- Mibrasa tongs [TG]
- Grill brush [CEP]
- Mibrasa Ecofire firelighters [FL]

OPTIONAL ACCESSORIES

- V-shape grill [GV100]
- Extra rod grill [CPV100]
- End of service lid [TAPAGMB100]
- Thermal protector [EPGMB100]
- Espeto skewer kit [KITESPGMB100]
- GN support kit [SGN100]

Specifications and design are subject to change without notice.

QUALITY GUARANTEE





Parrilla GMB 100

FRONT VIEW

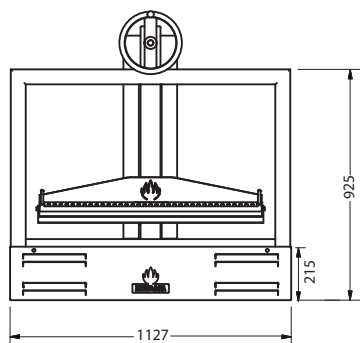

SIDE VIEW

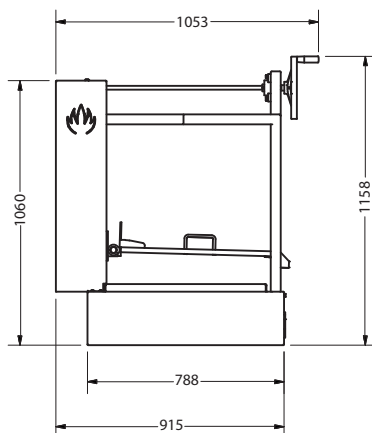

TOP VIEW

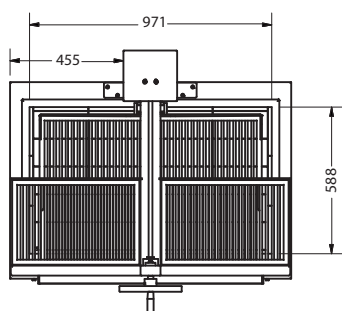

Dimensions in mm

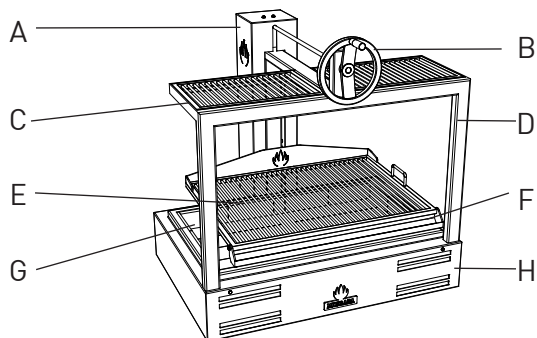

| | |
|---|--------------------------|
| A | Reverse elevating system |
| B | Elevating wheel |
| C | Heating rack |
| D | Structure |
| E | Grill |
| F | Grease collector |
| G | Refractory bricks |
| H | Main body |

GRILL TYPES

Rod bar grill

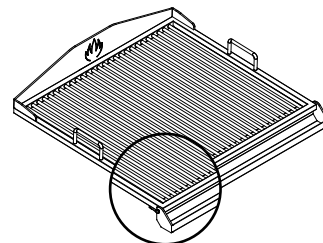

V-shape grill

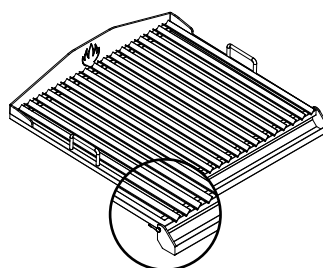

GRILL DIMENSIONS

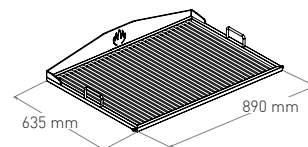

HEATING RACK DIMENSIONS

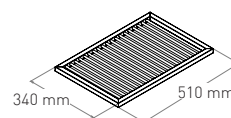

Revit drawings available on request at mibrasa@mibrasa.com

INSTALLATION GUIDELINES AND SAFETY STANDARDS

| | |
|---|--------|
| Recommended installation height | 700 mm |
| Clearances to construction/other appliances from the Parrilla | 76 mm |
| Clearances of flammable materials from the Parrilla | 300 mm |
| Clearance of workspace from front of the Parrilla | 700 mm |



*It is recommended to use a lifting device to lift the Parrilla and place on the countertop/stand.

Consult Parrilla instruction manual for further information.

Specifications and design are subject to change without notice.



Parrilla GMB 100

OPTIONAL COMPLETE STAND



TECHNICAL INFORMATION

| | |
|----------------------------|-----------------------|
| Ref. | GMB100 + MCGMB100 |
| Net weight ³ | 349 kg |
| Crated weight ³ | 467 kg |
| Crated size (WxDxH) | 1120 x 1310 x 2000 mm |

| | |
|----------------------------|----------------------|
| Ref. | MCGMB100 |
| Net weight ³ | 84 kg |
| Crated weight ³ | 99 kg |
| Crated size (WxDxH) | 1120 x 1310 x 700 mm |
| No. drawers | 3 |
| No. GN rack slots | 5 |

OPTIONAL ACCESSORIES

- S/S Casters [WINOX]

Dimensions in mm

FRONT VIEW

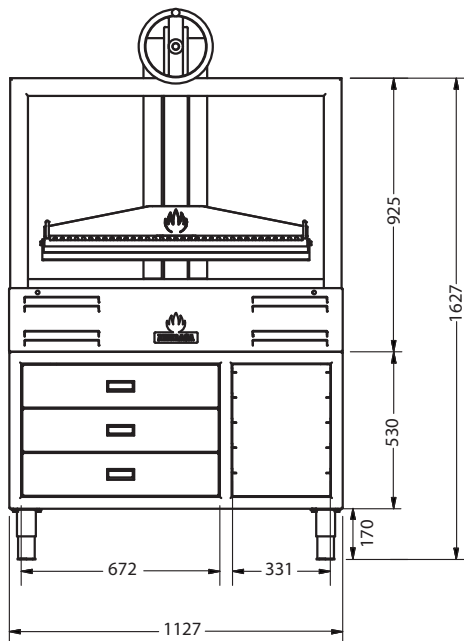

SIDE VIEW

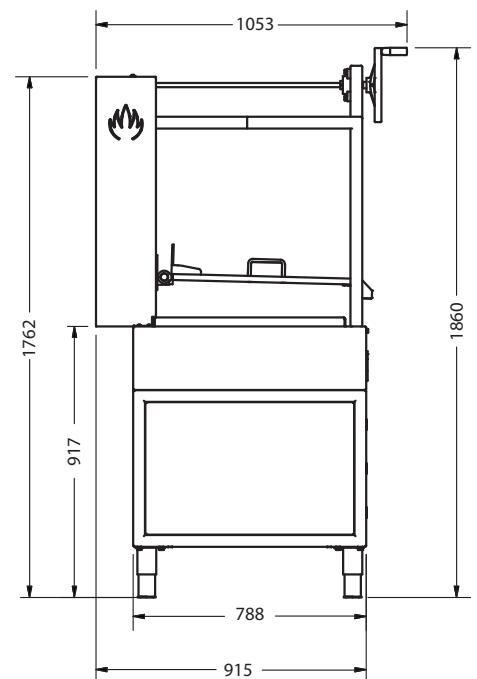

Dimensions in mm

Specifications and design are subject to change without notice.



Parrilla GMB 100

OPTIONAL STAND



TECHNICAL INFORMATION

| | |
|----------------------------|-----------------------|
| Ref. | GMB100 + MGMB100 |
| Net weight ³ | 300 kg |
| Crated weight ³ | 418 kg |
| Crated size (WxDxH) | 1120 x 1310 x 2000 mm |

| | |
|----------------------------|----------------------|
| Ref. | MGMB100 |
| Net weight ³ | 35 kg |
| Crated weight ³ | 50 kg |
| Crated size (WxDxH) | 1120 x 1310 x 700 mm |

OPTIONAL ACCESSORIES

- S/S Casters [WINOX]
- Gastronorm rack [SGN100]

Dimensions in mm

FRONT VIEW

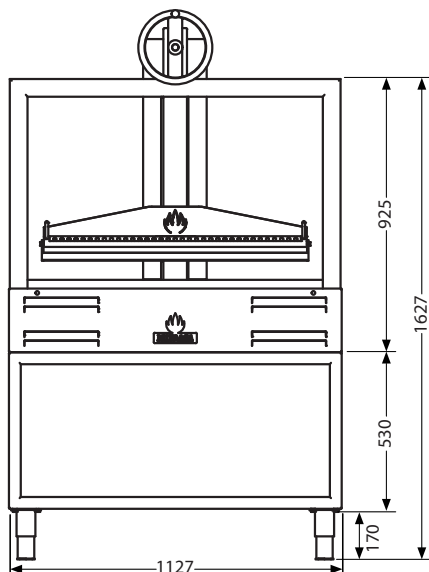

SIDE VIEW

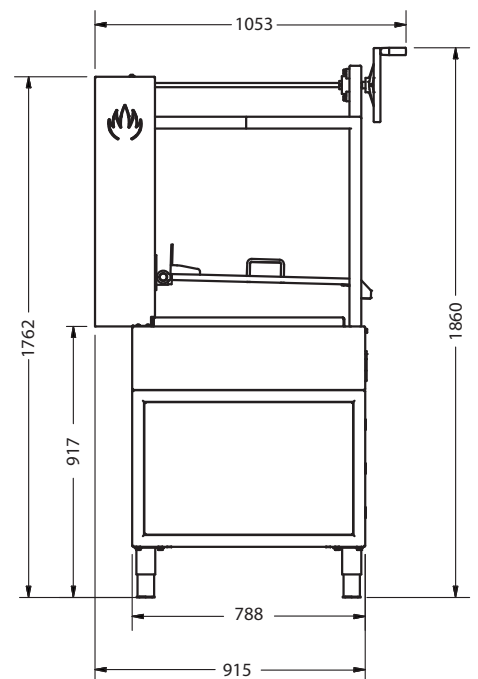

Dimensions in mm

Specifications and design are subject to change without notice.