

Refrigerated Prep Counters

With Raised Collar

Working area depth 300mm

HBC2EN



Product should be refrigerated prior to placing in raised collar

HBC3EN



HBC2EN

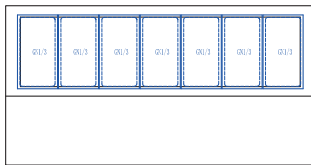

HBC3EN

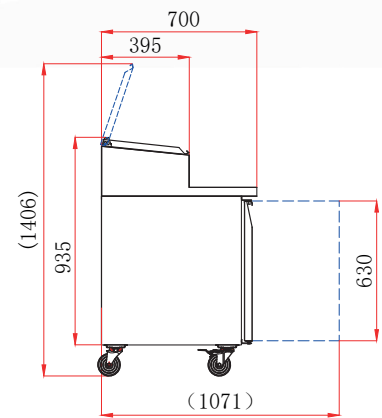
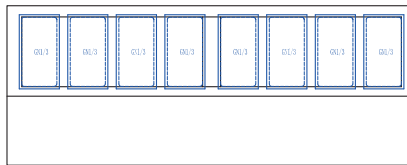

FEATURES

- Stainless steel exterior & interior
- Even air distribution by ducted system
- Available with 2 or 3 drawer option
- Raised collar accepts GN1/3 containers – max 150mm deep (not supplied)
- Working area depth 300mm
- 1 x adjustable GN1/1 shelf per door
- Heavy duty castors as standard
- Self closing doors
- Replaceable door gasket

TECHNICAL SPECIFICATIONS

Controller:	Dixell controller
Cooling:	Ventilated
Defrost:	Automatic
Refrigerant:	R290
Climate Class:	4
Temperature Range:	+2°C ~ +8°C
Decibels:	42dBA
Power Supply:	13amp

MODEL	DOOR	CONTAINER CAPACITY	GROSS CAPACITY	EXT. DIMENSIONS (H x W x D mm)	POWER CONSUMPTION	WEIGHT (kg)	RRP
HBC2EN	2	7 x GN1/3	282L	1075 x 1360 x 700	350W	120	
HBC3EN	3	8 x GN1/3	417L	1075 x 1795 x 700	350W	146	
2 Drawer Pack							
3 Drawer Pack							



See page 9 for full GN container range

