



DESIGNED SMART. BUILT SOLID.®

INSTALLATION AND OPERATING INSTRUCTIONS

Models: HDDi/HDDiS/HDXi HOLDING DRAWERS

INTENDED FOR OTHER THAN HOUSEHOLD USE

UNIT MUST BE KEPT CLEAR OF COMBUSTIBLES AT ALL TIMES

FOR YOUR SAFETY: Do not store or use gasoline or other flammable vapors and liquids in the vicinity of this or any other appliance.

WARNING: Improper installation, adjustment, alteration, service or maintenance can



X*PERT™ Series



WARNING: California Residents Only. This product can expose you to chemicals including chromium which is known to the State of California to cause cancer and birth defects or other reproductive harm. For more information go to www.P65Warnings.ca.gov.



cause property damage, injury or death. Read the Installation, Operating and Maintenance Instructions thoroughly before installing or servicing this equipment.



Initial heating of unit may generate smoke or fumes and must be done in a well ventilated area. Overexposure to smoke or fumes may cause nausea or dizziness.

APW Wyott® cooking equipment has been engineered to provide you with year-round dependable service when used according to the instructions in this manual and standard commercial kitchen practices.



APW Wyott Food Service Equipment Company
1307 N. Watters Road, Suite 180 • Allen, TX 75013

P/N 70503000 Rev 09/18

972.908.6100 Phone
214.565.0976 Fax

+1.800.527.2100
www.apwwyott.com

TABLE OF CONTENTS

SECTION	ITEM	PAGE
1	Owners Information.....	2
	General Information	2
	General Operation Instructions.....	2
	Warranty Information	2
2	Important Safety Information	3
3	Specifications.....	3
	Electrical	3
	Dimensions	4
4	Operation	5
5	Cleaning	6
	General Cleaning Instructions.....	6
	Daily Cleaning	6
6	Troubleshooting.....	6
7	Wiring Diagrams.....	7
8	HDDi/HDXi/HDDiS Counter Exploded View.....	9
	HDDi/HDXi Counter Parts List	10
	HDDiS Counter Parts List	12
9	HDDi/HDXi/HDDiS Built-In Exploded View	14
	HDDi/HDXi Built-In Parts List.....	15
	HDDiS Built-In Parts List.....	17
10	Warranty.....	20

1. OWNER'S INFORMATION

General Information:

1. Always clean equipment thoroughly before first use. (See general cleaning instructions).
2. Check rating label for your model designation and electrical rating.
3. For best results, use stainless steel countertops.
4. All dimensions in parenthesis in centimeters unless noted.
5. Legs are shipped unassembled. Legs must be screwed into base of unit.

General Operation Instructions:

1. All foodservice equipment should be operated by trained personnel.
2. Do not allow your customers to come in contact with any surface labeled "CAUTION HOT".
3. Where applicable: Never pour cold water into dry heated units.
4. Never hold food below 150°F (66°C).

Warranty Information:

Reliability Backed By APW Wyott's Warranty:

All APW Wyott Holding Drawers are backed by a one year parts and labor warranty, including On-Site Service calls within 50 miles of authorized service technicians.

Service Information:

Service Hotline (800) 733-2203

2. SAFETY INFORMATION

APW Wyatt® Holding Drawers are designed, built and sold for commercial use and should be operated by trained personnel only. Clearly post all CAUTIONS, WARNINGS and OPERATING INSTRUCTIONS near each unit to insure proper operation and to reduce the chance of personal injury and/or equipment damage.

Always disconnect power before servicing the Holding Drawer. Surfaces will remain hot after power has been turned off. Allow unit to cool before cleaning or servicing. Never clean the Holding Drawer by immersing it in water. The Holding Drawer is not protected against water jets; DO NOT CLEAN HOLDING DRAWER WITH A WATER JET. Always clean equipment before first use.

3. SPECIFICATIONS

Cordset Configuration:

HDDi/HDDiS/HDXi -1-120 USES NEMA 5-15P

HDDi/HDDiS/HDXi -1-208 USES NEMA 6-15P

HDDi/HDDiS/HDXi -1-240 USES NEMA 6-15P

HDDi/HDDiS/HDXi -3-120 USES NEMA 5-15P

HDDi/HDDiS/HDXi -3-208 USES NEMA 6-15P

HDDi/HDDiS/HDXi -3-240 USES NEMA 6-15P

HDDi/HDDiS/HDXi -2-120 USES NEMA 5-15P

HDDi/HDDiS/HDXi -2-208 USES NEMA 6-15P

HDDi/HDDiS/HDXi -2-240 USES NEMA 6-15P

HDXi-4-120 USES NEMA 5-20P

HDXi-4-208 USES NEMA 6-15P

HDXi-4-240 USES NEMA 6-15P

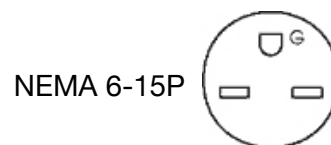
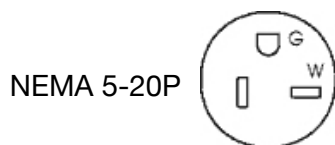
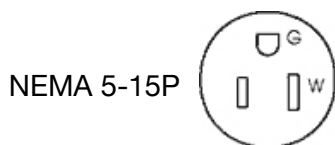

If the supply cord is damaged, the manufacturer or an authorized service agent or a similarly qualified person must replace it to avoid a hazard or voiding the warranty.

WARNING: ELECTRICAL SHOCK HAZARD. FAILURE TO FOLLOW THE INSTRUCTIONS IN THIS MANUAL COULD RESULT IN SERIOUS INJURY OR DEATH.

- Electrical Ground is required on this appliance.
- DO NOT modify the power supply cord plug. If it does not fit into the outlet, have the proper outlet installed by a qualified electrician.
- DO NOT use an extension cord with this appliance.
- Check with a qualified electrician if you are unsure as to whether the appliance is properly grounded.

Overall Dimensions & Electrical Specifications

Model Number	Volts Hz	Power Rating	Amps	Overall Height		Overall Width		Overall Depth		Cutout Built-in	Shipping Weight
				Counter	Built-in	Counter	Built-in	Counter	Built-in		
	V (Hz)	Watts	A	in (mm)		in (mm)		in (mm)		in (mm)	lbs (kg)
HDDi-1-120	120 (50/60)	450	3.75	14-7/8 (378)	10-3/8 (263)	27-3/4 (704)	27-3/4 (704)	21 (534)	20-5/8 (524)	10-3/4x28 (273x711)	125 (57)
HDDi-1-208	208 (50/60)	450	2.16	14-7/8 (378)	10-3/8 (263)	27-3/4 (704)	27-3/4 (704)	21 (534)	20-5/8 (524)	10-3/4x28 (273x711)	125 (57)
HDDi-1-240	240 (50/60)	450	1.88	14-7/8 (378)	10-3/8 (263)	27-3/4 (704)	27-3/4 (704)	21 (534)	20-5/8 (524)	10-3/4x28 (273x711)	125 (57)
HDDi-2-120	120 (50/60)	900	7.50	24-1/4 (616)	19-3/4 (501)	27-3/4 (704)	27-3/4 (704)	21 (534)	20-5/8 (524)	20x28 (508x711)	175 (79)
HDDi-2-208	208 (50/60)	900	4.33	24-1/4 (616)	19-3/4 (501)	27-3/4 (704)	27-3/4 (704)	21 (534)	20-5/8 (524)	20x28 (508x711)	175 (79)
HDDi-2-240	240 (50/60)	900	3.75	24-1/4 (616)	19-3/4 (501)	27-3/4 (704)	27-3/4 (704)	21 (534)	20-5/8 (524)	20x28 (508x711)	175 (79)
HDDi-3-120	120 (50/60)	1350	11.25	33-5/8 (852)	29-1/4 (740)	27-3/4 (704)	27-3/4 (704)	21 (534)	20-5/8 (524)	29-1/2x28 (749x711)	225 (102)
HDDi-3-208	208 (50/60)	1350	6.49	33-5/8 (852)	29-1/4 (740)	27-3/4 (704)	27-3/4 (704)	21 (534)	20-5/8 (524)	29-1/2x28 (749x711)	225 (102)
HDDi-3-240	240 (50/60)	1350	5.63	33-5/8 (852)	29-1/4 (740)	27-3/4 (704)	27-3/4 (704)	21 (534)	20-5/8 (524)	29-1/2x28 (749x711)	225 (102)
HDDiS-1-120	120 (50/60)	450	3.75	14-7/8 (378)	11-1/16 (281)	20-1/4 (515)	20-1/4 (515)	29 (737)	28-5/8 (727)	11-1/4x20-1/2 (286x521)	125 (57)
HDDiS-1-208	208 (50/60)	450	2.16	14-7/8 (378)	11-1/16 (281)	20-1/4 (515)	20-1/4 (515)	29 (737)	28-5/8 (727)	11-1/4x20-1/2 (286x521)	125 (57)
HDDiS-1-240	240 (50/60)	450	1.88	14-7/8 (378)	11-1/16 (281)	20-1/4 (515)	20-1/4 (515)	29 (737)	28-5/8 (727)	11-1/4x20-1/2 (286x521)	125 (57)
HDDiS-2-120	120 (50/60)	900	7.50	24-1/4 (616)	20-7/16 (519)	20-1/4 (515)	20-1/4 (515)	29 (737)	28-5/8 (727)	20-3/4x20-1/2 (527x521)	175 (79)
HDDiS-2-208	208 (50/60)	900	4.33	24-1/4 (616)	20-7/16 (519)	20-1/4 (515)	20-1/4 (515)	29 (737)	28-5/8 (727)	20-3/4x20-1/2 (527x521)	175 (79)
HDDiS-2-240	240 (50/60)	900	3.75	24-1/4 (616)	20-7/16 (519)	20-1/4 (515)	20-1/4 (515)	29 (737)	28-5/8 (727)	20-3/4x20-1/2 (527x521)	175 (79)
HDDiS-3-120	120 (50/60)	1350	11.25	33-5/8 (852)	29-13/16 (757)	20-1/4 (515)	20-1/4 (515)	29 (737)	28-5/8 (727)	30x20-1/2 (762x521)	225 (102)
HDDiS-3-208	208 (50/60)	1350	6.49	33-5/8 (852)	29-13/16 (757)	20-1/4 (515)	20-1/4 (515)	29 (737)	28-5/8 (727)	30x20-1/2 (762x521)	225 (102)
HDDiS-3-240	240 (50/60)	1350	5.63	33-5/8 (852)	29-13/16 (757)	20-1/4 (515)	20-1/4 (515)	29 (737)	28-5/8 (727)	30x20-1/2 (762x521)	225 (102)
HDXi-1-120	120 (50/60)	450	3.75	14-7/8 (378)	10-3/8 (263)	27-3/4 (704)	27-3/4 (704)	21 (534)	20-5/8 (524)	10-3/4x28 (273x711)	125 (57)
HDXi-1-208	208 (50/60)	450	2.16	14-7/8 (378)	10-3/8 (263)	27-3/4 (704)	27-3/4 (704)	21 (534)	20-5/8 (524)	10-3/4x28 (273x711)	125 (57)
HDXi-1-240	240 (50/60)	450	1.88	14-7/8 (378)	10-3/8 (263)	27-3/4 (704)	27-3/4 (704)	21 (534)	20-5/8 (524)	10-3/4x28 (273x711)	125 (57)
HDXi-2-120	120 (50/60)	900	7.50	24-1/4 (616)	19-3/4 (501)	27-3/4 (704)	27-3/4 (704)	21 (534)	20-5/8 (524)	20x28 (508x711)	175 (79)
HDXi-2-208	208 (50/60)	900	4.33	24-1/4 (616)	19-3/4 (501)	27-3/4 (704)	27-3/4 (704)	21 (534)	20-5/8 (524)	20x28 (508x711)	175 (79)
HDXi-2-240	240 (50/60)	900	3.75	24-1/4 (616)	19-3/4 (501)	27-3/4 (704)	27-3/4 (704)	21 (534)	20-5/8 (524)	20x28 (508x711)	175 (79)
HDXi-3-120	120 (50/60)	1350	11.25	33-5/8 (852)	29-1/4 (740)	27-3/4 (704)	27-3/4 (704)	21 (534)	20-5/8 (524)	29-1/2x28 (749x711)	225 (102)
HDXi-3-208	208 (50/60)	1350	6.49	33-5/8 (852)	29-1/4 (740)	27-3/4 (704)	27-3/4 (704)	21 (534)	20-5/8 (524)	29-1/2x28 (749x711)	225 (102)
HDXi-3-240	240 (50/60)	1350	5.63	33-5/8 (852)	29-1/4 (740)	27-3/4 (704)	27-3/4 (704)	21 (534)	20-5/8 (524)	29-1/2x28 (749x711)	225 (102)
HDXi-4-120*	120 (50/60)	1800	15.00	45 (1092)	N/A	27-3/4 (704)	N/A	21 (534)	N/A	N/A	275 (125)
HDXi-4-208*	208 (50/60)	1800	8.65	45 (1092)	N/A	27-3/4 (704)	N/A	21 (534)	N/A	N/A	275 (125)
HDXi-4-240*	240 (50/60)	1800	7.50	45 (1092)	N/A	27-3/4 (704)	N/A	21 (534)	N/A	N/A	275 (125)

*MODELS COME STANDARD WITH 6" LEGS

4. OPERATION

1. Set thermostat control to 190°F and preheat each drawer for 30 minutes.
2. Place food product directly in stainless steel drawer pans or use any combination of full or fractional pans up to 6" (152mm) deep.
3. Set front vent to desired position for maintaining food product moisture.
4. Perforated pans may be used with damp towel or small amount of hot water in the drawer pan to prevent food "dry out".

CAUTION: Use no more than 1 quart (1 liter) for wet operation.

5. If too much moisture accumulates around drawer front or vent, reduce temperature setting or move vent to "dry" position.

PRODUCT	TEMPERATURE SETTING	VENT
Rolls, Bread	160°-180°F (71°-82° C)	Moist
Vegetables	160°-180°F (71°-82° C)	Moist
Meats	160°-180°F (71°-82° C)	Moist

NOTE: Temperature and vent settings will require adjustment according to type and quantity of food, and number of times drawer is opened during operation.

Digital Controller Operation (HDXi models only)

With unit plugged in and the rocker switch in the "ON" position, the digital controller will come on. When the controller is on, the minimum set point value is preset to 100°F and the maximum set point is 300°F. To obtain the desired set point, push the set key and release. You have two seconds to adjust the set temperature. Press the up or down key to your desired setting. After setting desired temperature, release up or down key and press the set key. The controller display should return to the measured temperature of the unit.

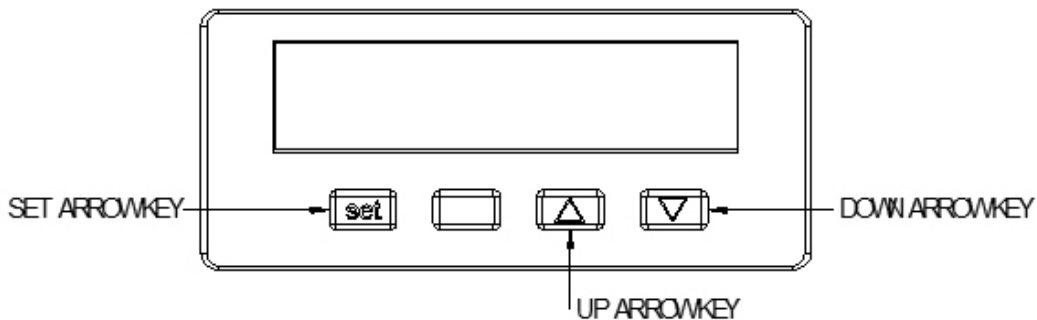

5. CLEANING

General Cleaning Instructions:

1. NEVER clean any electrical unit by immersing it in water. Turn off before surface cleaning.
2. Always clean equipment thoroughly before first use. Clean unit daily. Use warm, soapy water. Mild cleansers and PLASTIC scouring pads may be used to remove baked-on food and water scale.
3. Turn off electrical units before cleaning or servicing. All service should be performed by an APW authorized service agency.

Daily Cleaning:

1. Follow General Cleaning instructions (above).
2. Remove any inset pans and drawer pans. Wash thoroughly in the sink or dishwasher.
3. Remove drawer: Remove pans and pan inserts. Extend drawer and lift up on the front to clear the drawer stop. Lower drawer and lift over front cabinet bearing.

6. TROUBLESHOOTING GUIDE

Always ask and check the following:

1. Is the unit connected to a live power source of the proper voltage?
2. Check the circuit breaker.
3. Is power switch "ON" (HDXi models only)?
4. Is the thermostat set to a temperature?
5. Is the Pilot light glowing?
6. Check the rating label. Is the unit connected to the correct power source?

7. WIRING DIAGRAMS

HDDi/HDDiS WIRING DIAGRAMS

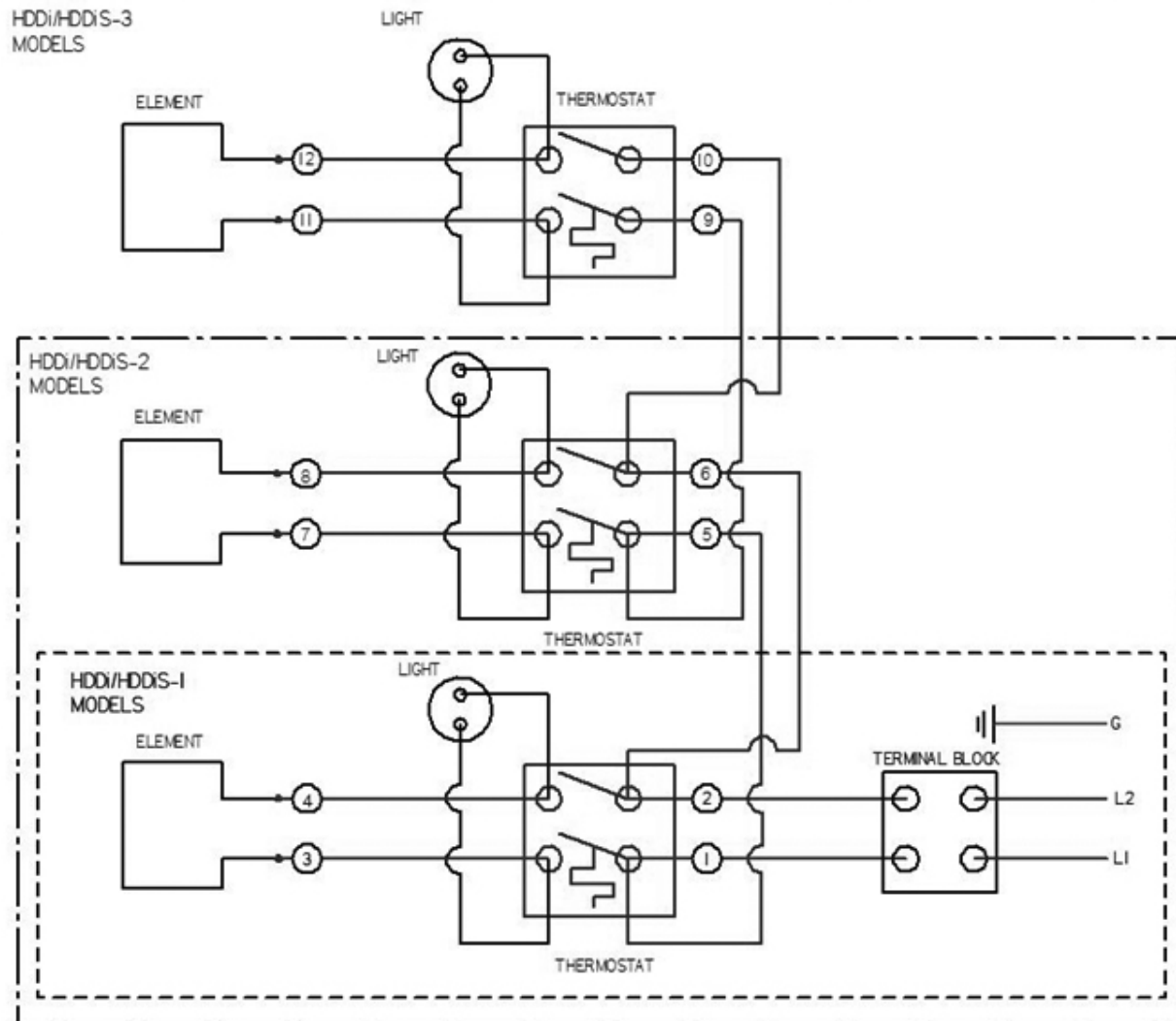

NOTE: Wire #'s 5 & 6 are not used in HDDi/HDDiS-1. Wire #'s 9 & 10 are only used in HDDi/HDDiS-3

HDXi WIRING DIAGRAM

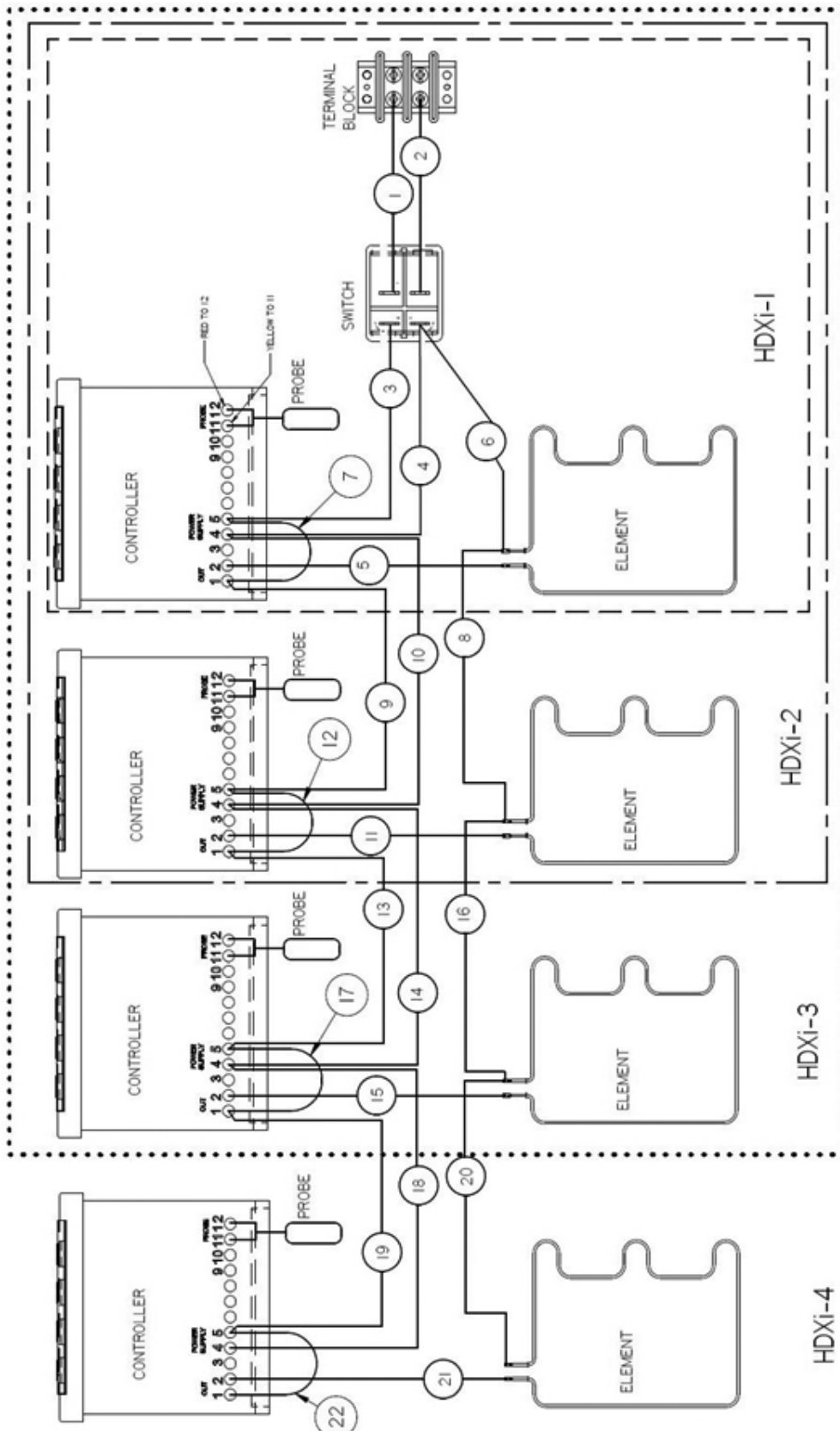

HDDi/HDDiS/HDXi PART BREAKDOWN

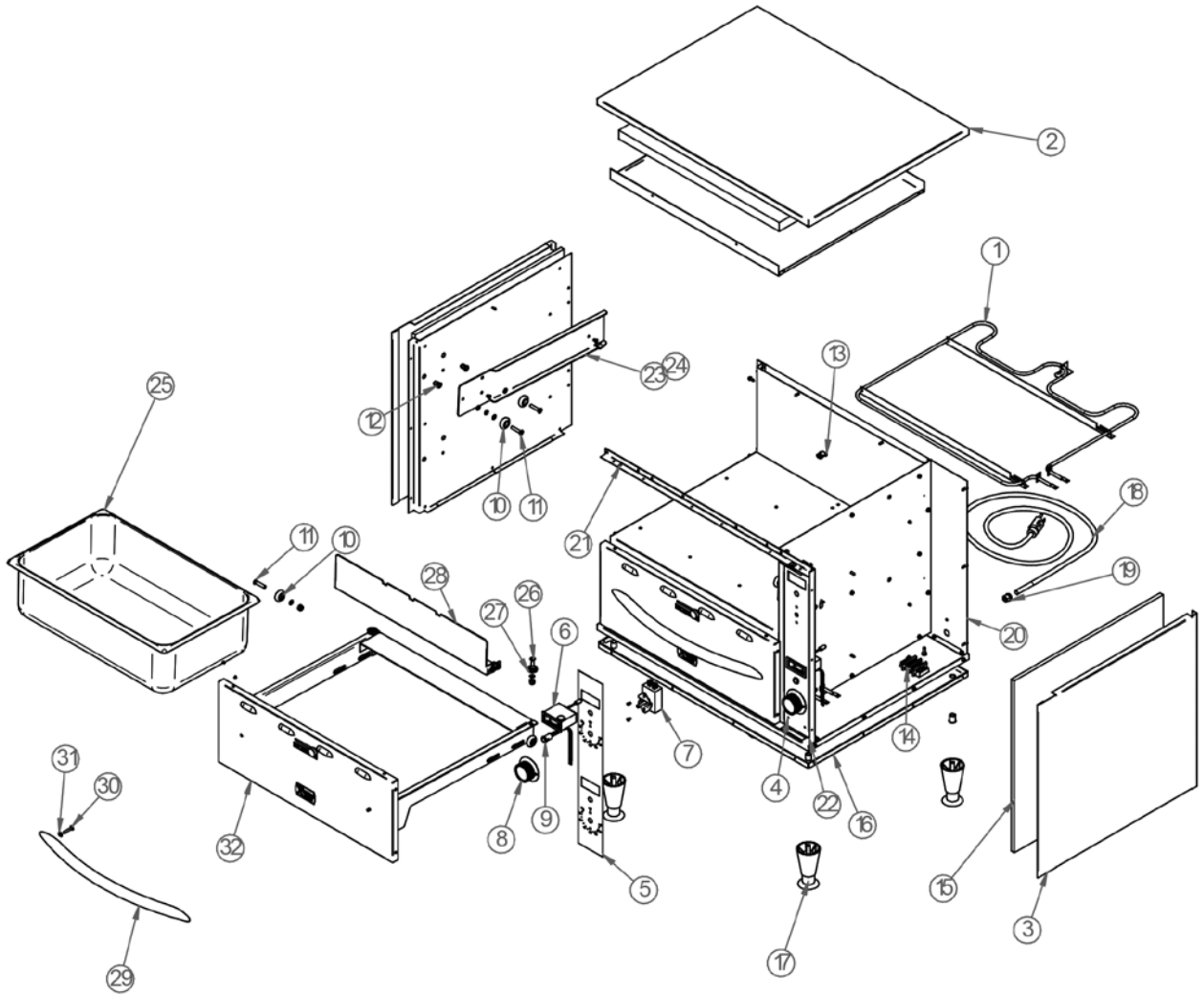

PARTS LIST(QTY'S)

ITEM	PN	DESCRIPTION	HDDI-1			HDDI-2			HDDI-3			HDXI-1			HDXI-2			HDXI-3		
			120	208	240	120	208	240	120	208	240	120	208	240	120	208	240	120	208	240
1	70504805	HEATING ELEMENT, 120V	1			2			3			1			2			3		
	70504806	HEATING ELEMENT, 208V		1			2			3		1			2				3	
	70504807	HEATING ELEMENT, 240V			1			2			3		1			2				3
2	33936	TOP COVER	1	1	1	1	1	1	1	1	1	1	1	1	1	1	1	1	1	1
3	33973	OUTER SIDE PANEL	2	2	2							2	2	2						
	33934	OUTER SIDE PANEL				2	2	2							2	2	2			
	33990	OUTER SIDE PANEL							2	2	2							2	2	2
4	33976	CONTROL PANEL	1	1	1															
	33952	CONTROL PANEL				1	1	1												
	33993	CONTROL PANEL							1	1	1									
	70502096	CONTROL PANEL										1	1	1						
	70502097	CONTROL PANEL												1	1	1				
	70502098	CONTROL PANEL																1	1	1
5	58269	CONTROL DECAL	1	1	1															
	58270	CONTROL DECAL				1	1	1												
	58271	CONTROL DECAL							1	1	1									
	58273	CONTROL DECAL										1	1	1						
	58274	CONTROL DECAL												1	1	1				
	58275	CONTROL DECAL																1	1	1
6	69145	THERMOMETER	1	1	1	2	2	2	3	3	3									
	70101034	DIGITAL CONTROLLER 120V										1			2			3		
	70101035	DIGITAL CONTROLLER 240V											1	1		2	2		3	3
	70101026	TEMPERATURE PROBE (120V/240V)										1	1	1	2	2	2	3	3	3
7	69121	THERMOSTAT	1	1	1	2	2	2	3	3	3									
8	56508	KNOB	1	1	1	2	2	2	3	3	3									
9	1509600	PILOT LIGHT	1	1	1	2	2	2	3	3	3									
10	33858	DRAWER SLIDE ROLLER	6	6	6	12	12	12	18	18	18	6	6	6	12	12	12	18	18	18
11	89013	MACHINE SCREW	6	6	6	12	12	12	18	18	18	6	6	6	12	12	12	18	18	18
12	8353200	RIVNUT	8	8	8	16	16	16	24	24	24	8	8	8	16	16	16	24	24	24
13	8945500	LOOP CLAMP S/S	1	1	1	2	2	2	3	3	3	1	1	1	2	2	2	3	3	3
14	30203	TERMINAL BLOCK	1	1	1	1	1	1	1	1	1	1	1	1	1	1	1	1	1	1
15	60113	INSULATION 21X19X1	4	4	4	6	6	6	9	9	9	4	4	4	6	6	6	9	9	9
16	70502086	LEG SUPPORT BASE	4	4	4	6	6	6	9	9	9	4	4	4	6	6	6	9	9	9

PARTS LIST(QTY'S)

ITEM	PN	DESCRIPTION	HDDI-1			HDDI-2			HDDI-3			HDXI-1			HDXI-2			HDXI-3		
			120	208	240	120	208	240	120	208	240	120	208	240	120	208	240	120	208	240
17	87327	LEG, STAINLESS 6" (OPTIONAL)	4	4	4	4	4	4	4	4	4	4	4	4	4	4	4	4	4	4
	0-999-000	CASTER, 3" (OPTIONALKIT OF 4)	1	1	1	1	1	1	1	1	1	1	1	1	1	1	1	1	1	1
	0-999-002	CASTER, 5" (OPTIONAL KIT OF 4)	1	1	1	1	1	1	1	1	1	1	1	1	1	1	1	1	1	1
18	1532500	CORDSET	1			1			1			1			1			1		
	85645	CORDSET		1	1		1	1		1	1		1	1		1	1		1	1
19	89101	STRAIN RELEIF	1	1	1	1	1	1	1	1	1	1	1	1	1	1	1	1	1	1
20	70502092	OUTER BACK PANEL	1	1	1							1	1	1						
	70502082	OUTER BACK PANEL				1	1	1						1	1	1				
	70502094	OUTER BACK PANEL							1	1	1						1	1	1	
21	33930	TOP BRACE ASSY	1	1	1	1	1	1	1	1	1	1	1	1	1	1	1	1	1	1
22	33975	RIGHT SIDE BRACE	1	1	1							1	1	1						
	33951	RIGHT SIDE BRACE				1	1	1						1	1	1				
	33992	RIGHT SIDE BRACE							1	1	1						1	1	1	
23	70502072	RIGHT SIDE DRAWER SLIDE	1	1	1	2	2	2	3	3	3	1	1	1	2	2	2	3	3	3
24	70502073	LEFT SIDE DRAWER SLIDE	1	1	1	2	2	2	3	3	3	1	1	1	2	2	2	3	3	3
25	70502077	STANDARD PAN 12X20	1	1	1	2	2	2	3	3	3	1	1	1	2	2	2	3	3	3
26	88987	SCREW, 1/4-20X3/4"	2	2	2	4	4	4	6	6	6	2	2	2	4	4	4	6	6	6
27	70502042	FLAT ROLLER BEARING	2	2	2	4	4	4	6	6	6	2	2	2	4	4	4	6	6	6
28	70502070	CENTER PAN SUPPORT ASSY	1	1	1	2	2	2	3	3	3	1	1	1	2	2	2	3	3	3
29	55611	HANDLE (ALSO NEED 30&31)	1	1	1	2	2	2	3	3	3	1	1	1	2	2	2	3	3	3
30	8164100	SCREW, 10-24X1"	2	2	2	4	4	4	6	6	6	2	2	2	4	4	4	6	6	6
31	89070	WASHER, #10 INTERNAL TEETH	2	2	2	4	4	4	6	6	6	2	2	2	4	4	4	6	6	6
32	70502060	DRAWER ASSY (INCLUDES 25-31)	1	1	1	2	2	2	3	3	3	1	1	1	2	2	2	3	3	3
N/A	70502045	WIRE SET	1	1	1							1	1	1						
N/A	70502047	WIRE SET				1	1	1						1	1	1				
N/A	70502049	WIRE SET							1	1	1						1	1	1	
N/A	70503000	MANUAL	1	1	1	1	1	1	1	1	1	1	1	1	1	1	1	1	1	1

PARTS LIST(QTY'S)

ITEM	PN	DESCRIPTION	HDDIS-1			HDDIS-2			HDDIS-3			HDXIS-1			HDXIS-2			HDXIS-3		
			120	208	240	120	208	240	120	208	240	120	208	240	120	208	240	120	208	240
1	54114	HEATING ELEMENT, 120V	1			2			3			1			2			3		
	54115	HEATING ELEMENT, 208V		1			2			3			1			2			3	
	54116	HEATING ELEMENT, 240V			1			2			3			1			2			3
2	70501039	TOP COVER	1	1	1	1	1	1	1	1	1	1	1	1	1	1	1	1	1	1
3	70501043	OUTER SIDE PANEL	2	2	2							2	2	2						
	70501017	OUTER SIDE PANEL				2	2	2							2	2	2			
	70501049	OUTER SIDE PANEL							2	2	2							2	2	2
4	33976	CONTROL PANEL	1	1	1															
	33952	CONTROL PANEL				1	1	1												
	33993	CONTROL PANEL							1	1	1									
	70502096	CONTROL PANEL										1	1	1						
	70502097	CONTROL PANEL													1	1	1			
	70502098	CONTROL PANEL																1	1	1
5	58269	CONTROL DECAL	1	1	1															
	58270	CONTROL DECAL				1	1	1												
	58271	CONTROL DECAL							1	1	1									
	58273	CONTROL DECAL										1	1	1						
	58274	CONTROL DECAL													1	1	1			
	58275	CONTROL DECAL																1	1	1
6	69145	THERMOMETER	1	1	1	2	2	2	3	3	3									
	70101034	DIGITAL CONTROLLER 120V										1			2			3		
	70101035	DIGITAL CONTROLLER 240V											1	1		2	2		3	3
	70101026	TEMPERATURE PROBE (120V/240V)										1	1	1	2	2	2	3	3	3
7	69121	THERMOSTAT	1	1	1	2	2	2	3	3	3									
8	56508	KNOB	1	1	1	2	2	2	3	3	3									
9	1509600	PILOT LIGHT	1	1	1	2	2	2	3	3	3									
10	33858	DRAWER SLIDE ROLLER	6	6	6	12	12	12	18	18	18	6	6	6	12	12	12	18	18	18
11	89013	MACHINE SCREW	6	6	6	12	12	12	18	18	18	6	6	6	12	12	12	18	18	18
12	8353200	RIVNUT	8	8	8	16	16	16	24	24	24	8	8	8	16	16	16	24	24	24
13	8945500	LOOP CLAMP S/S	1	1	1	2	2	2	3	3	3	1	1	1	2	2	2	3	3	3
14	30203	TERMINAL BLOCK	1	1	1	1	1	1	1	1	1	1	1	1	1	1	1	1	1	1
15	60113	INSULATION 21X19X1	4	4	4	6	6	6	9	9	9	4	4	4	6	6	6	9	9	9
16	70501034	LEG SUPPORT BASE	1	1	1	1	1	1	1	1	1	1	1	1	1	1	1	1	1	1

PARTS LIST(QTY'S)

ITEM	PN	DESCRIPTION	HDDIS-1			HDDIS-2			HDDIS-3			HDXIS-1			HDXIS-2			HDXIS-3		
			120	208	240	120	208	240	120	208	240	120	208	240	120	208	240	120	208	240
17	87327	LEG, STAINLESS 6" (OPTIONAL)	4	4	4	4	4	4	4	4	4	4	4	4	4	4	4	4	4	4
	0-999-000	CASTER, 3" (OPTIONAL KIT OF 4)	1	1	1	1	1	1	1	1	1	1	1	1	1	1	1	1	1	1
	0-999-002	CASTER, 5" (OPTIONAL KIT OF 4)	1	1	1	1	1	1	1	1	1	1	1	1	1	1	1	1	1	1
18	1532500	CORDSET	1			1			1			1			1			1		
	85645	CORDSET		1	1		1	1		1	1		1	1		1	1		1	1
19	89101	STRAIN RELIEF	1	1	1	1	1	1	1	1	1	1	1	1	1	1	1	1	1	1
20	70502092	OUTER BACK PANEL	1	1	1							1	1	1						
	70502082	OUTER BACK PANEL				1	1	1							1	1	1			
	70502094	OUTER BACK PANEL							1	1	1							1	1	1
21	33930	TOP BRACE ASSY	1	1	1	1	1	1	1	1	1	1	1	1	1	1	1	1	1	1
22	33975	RIGHT SIDE BRACE	1	1	1							1	1	1						
	33951	RIGHT SIDE BRACE				1	1	1							1	1	1			
	33992	RIGHT SIDE BRACE							1	1	1							1	1	1
23	70502072	RIGHT SIDE DRAWER SLIDE	1	1	1	2	2	2	3	3	3	1	1	1	2	2	2	3	3	3
24	70502073	LEFT SIDE DRAWER SLIDE	1	1	1	2	2	2	3	3	3	1	1	1	2	2	2	3	3	3
25	70502077	STANDARD PAN 12X20	1	1	1	2	2	2	3	3	3	1	1	1	2	2	2	3	3	3
26	88987	SCREW, 1/4-20X3/4"	2	2	2	4	4	4	6	6	6	2	2	2	4	4	4	6	6	6
27	70502042	FLAT ROLLER BEARING	2	2	2	4	4	4	6	6	6	2	2	2	4	4	4	6	6	6
28	70502070	CENTER PAN SUPPORT ASSY	1	1	1	2	2	2	3	3	3	1	1	1	2	2	2	3	3	3
29	55611	HANDLE (ALSO NEED 30&31)	1	1	1	2	2	2	3	3	3	1	1	1	2	2	2	3	3	3
30	8164100	SCREW, 10-24X1"	2	2	2	4	4	4	6	6	6	2	2	2	4	4	4	6	6	6
31	89070	WASHER, #10 INTERNAL TEETH	2	2	2	4	4	4	6	6	6	2	2	2	4	4	4	6	6	6
32	70502060	DRAWER ASSY (INCLUDES 25-31)	1	1	1	2	2	2	3	3	3	1	1	1	2	2	2	3	3	3
N/A	70502045	WIRE SET	1	1	1							1	1	1						
N/A	70502047	WIRE SET				1	1	1							1	1	1			
N/A	70502049	WIRE SET							1	1	1							1	1	1
N/A	70503000	MANUAL	1	1	1	1	1	1	1	1	1	1	1	1	1	1	1	1	1	1

HDDi/HDDiS/HDXi BUILT IN PART BREAKDOWN

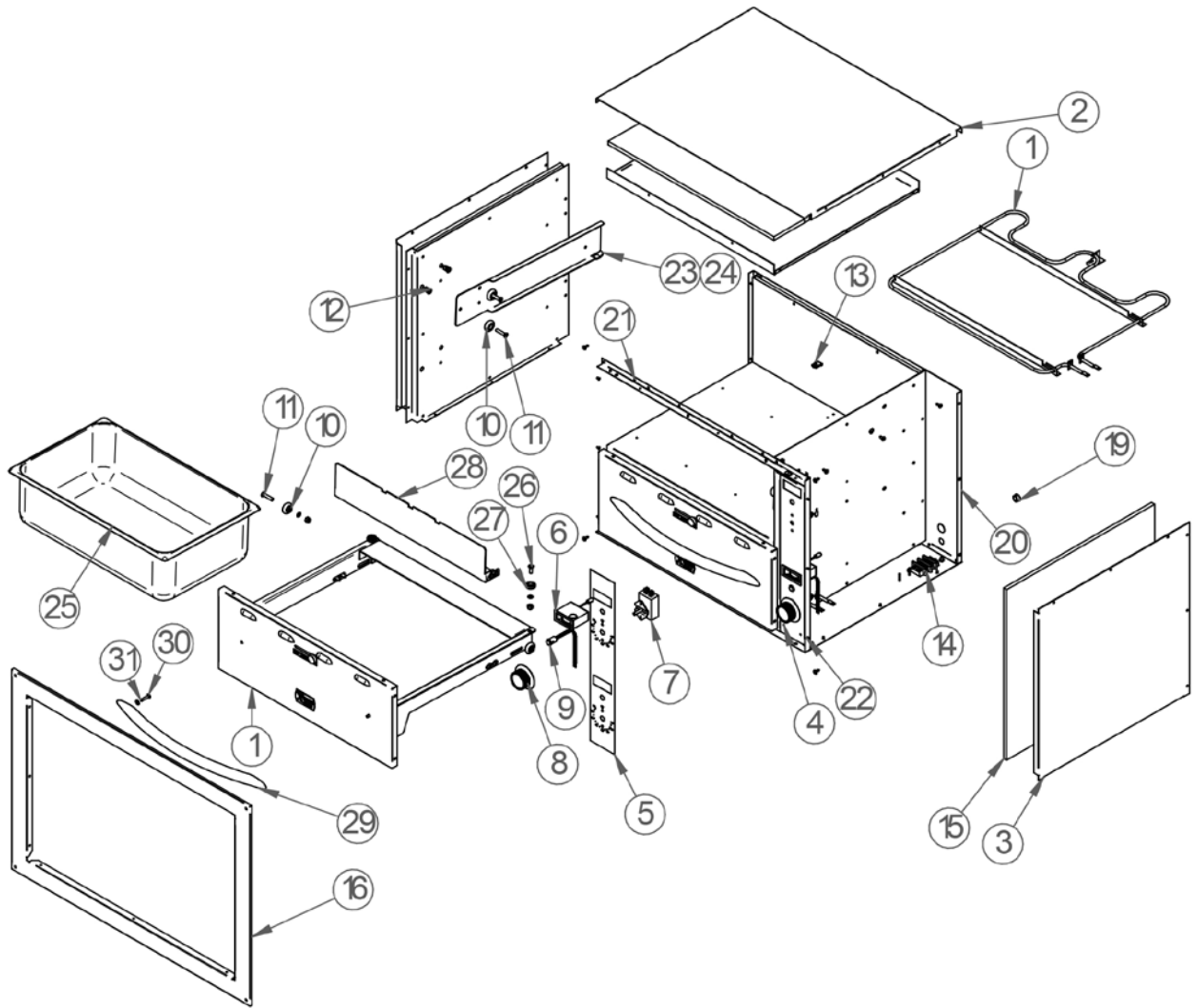

PARTS LIST(QTY'S)

ITEM	PN	DESCRIPTION	HDDI-1			HDDI-2			HDDI-3			HDXI-1			HDXI-2			HDXI-3		
			120	208	240	120	208	240	120	208	240	120	208	240	120	208	240	120	208	240
1	70504805	HEATING ELEMENT, 120V	1			2			3			1			2			3		
	70504806	HEATING ELEMENT, 208V		1		2			3			1			2			3		
	70504807	HEATING ELEMENT, 240V			1		2		3			1			2			3		
2	70501039	TOP COVER	1	1	1	1	1	1	1	1	1	1	1	1	1	1	1	1	1	1
3	70501043	OUTER SIDE PANEL	2	2	2							2	2	2						
	70501017	OUTER SIDE PANEL				2	2	2							2	2	2			
	70501049	OUTER SIDE PANEL							2	2	2							2	2	2
4	33976	CONTROL PANEL	1	1	1															
	33952	CONTROL PANEL				1	1	1												
	33993	CONTROL PANEL							1	1	1									
	70502096	CONTROL PANEL										1	1	1						
	70502097	CONTROL PANEL													1	1	1			
	70502098	CONTROL PANEL																1	1	1
5	58269	CONTROL DECAL	1	1	1															
	58270	CONTROL DECAL				1	1	1												
	58271	CONTROL DECAL							1	1	1									
	58273	CONTROL DECAL										1	1	1						
	58274	CONTROL DECAL													1	1	1			
	58275	CONTROL DECAL																1	1	1
6	69145	THERMOMETER	1	1	1	2	2	2	3	3	3									
	70101034	DIGITAL CONTROLLER 120V										1			2			3		
	70101035	DIGITAL CONTROLLER 240V											1	1		2	2		3	3
	70101026	TEMPERATURE PROBE (120V/240V)										1	1	1	2	2	2	3	3	3
7	69121	THERMOSTAT	1	1	1	2	2	2	3	3	3									
8	56508	KNOB	1	1	1	2	2	2	3	3	3									
9	1509600	PILOT LIGHT	1	1	1	2	2	2	3	3	3									
10	33858	DRAWER SLIDE ROLLER	6	6	6	12	12	12	18	18	18	6	6	6	12	12	12	18	18	18
11	89013	MACHINE SCREW	6	6	6	12	12	12	18	18	18	6	6	6	12	12	12	18	18	18
12	8353200	RIVNUT	8	8	8	16	16	16	24	24	24	8	8	8	16	16	16	24	24	24
13	8945500	LOOP CLAMP S/S	1	1	1	2	2	2	3	3	3	1	1	1	2	2	2	3	3	3
14	30203	TERMINAL BLOCK	1	1	1	1	1	1	1	1	1	1	1	1	1	1	1	1	1	1
15	60113	INSULATION 21X19X1	4	4	4	6	6	6	9	9	9	4	4	4	6	6	6	9	9	9
16	33982	FRONT PLATE	1	1	1							1	1	1						
	33963	FRONT PLATE				1	1	1							1	1	1			
	33999	FRONT PLATE							1	1	1							1	1	1

PARTS LIST(QTY'S)

ITEM	PN	DESCRIPTION	HDDI-1			HDDI-2			HDDI-3			HDXI-1			HDXI-2			HDXI-3		
			120	208	240	120	208	240	120	208	240	120	208	240	120	208	240	120	208	240
19	84559	HOLE PLUG	1	1	1	1	1	1	1	1	1	1	1	1	1	1	1	1	1	1
20	70501047	OUTER BACK PANEL	1	1	1							1	1	1						
	70501027	OUTER BACK PANEL				1	1	1							1	1	1			
	70501055	OUTER BACK PANEL							1	1	1							1	1	1
21	70501057	TOP BRACE ASSY	1	1	1	1	1	1	1	1	1	1	1	1	1	1	1	1	1	1
22	33975	RIGHT SIDE BRACE	1	1	1							1	1	1						
	33951	RIGHT SIDE BRACE				1	1	1							1	1	1			
	33992	RIGHT SIDE BRACE							1	1	1							1	1	1
23	70501018	RIGHT SIDE DRAWER SLIDE	1	1	1	2	2	2	3	3	3	1	1	1	2	2	2	3	3	3
24	70501019	LEFT SIDE DRAWER SLIDE	1	1	1	2	2	2	3	3	3	1	1	1	2	2	2	3	3	3
25	70502077	STANDARD PAN 12X20	1	1	1	2	2	2	3	3	3	1	1	1	2	2	2	3	3	3
26	88987	SCREW, 1/4-20X3/4"	2	2	2	4	4	4	6	6	6	2	2	2	4	4	4	6	6	6
27	70502042	FLAT ROLLER BEARING	2	2	2	4	4	4	6	6	6	2	2	2	4	4	4	6	6	6
28	70501076	CENTER PAN SUPPORT ASSY	1	1	1	2	2	2	3	3	3	1	1	1	2	2	2	3	3	3
29	55613	HANDLE (ALSO NEED 30&31)	1	1	1	2	2	2	3	3	3	1	1	1	2	2	2	3	3	3
30	8164100	SCREW, 10-24X1"	2	2	2	4	4	4	6	6	6	2	2	2	4	4	4	6	6	6
31	89070	WASHER, #10 INTERNAL TEETH	2	2	2	4	4	4	6	6	6	2	2	2	4	4	4	6	6	6
32	70503200	DRAWER ASSY (INCLUDES 25-31)	1	1	1	2	2	2	3	3	3	1	1	1	2	2	2	3	3	3
N/A	70502045	WIRE SET	1	1	1							1	1	1						
N/A	70502047	WIRE SET				1	1	1							1	1	1			
N/A	70502049	WIRE SET							1	1	1							1	1	1
N/A	70503000	MANUAL	1	1	1	1	1	1	1	1	1	1	1	1	1	1	1	1	1	1

PARTS LIST(QTY'S)

ITEM	PN	DESCRIPTION	HDDIS-1			HDDIS-2			HDDIS-3			HDXIS-1			HDXIS-2			HDXIS-3		
			120	208	240	120	208	240	120	208	240	120	208	240	120	208	240	120	208	240
1	54114	HEATING ELEMENT, 120V	1			2			3			1			2			3		
	54115	HEATING ELEMENT, 208V		1			2			3			1			2			3	
	54116	HEATING ELEMENT, 240V			1			2			3			1			2			3
2	70501079	TOP COVER	1	1	1	1	1	1	1	1	1	1	1	1	1	1	1	1	1	1
3	70501081 70501082	OUTER RIGHT SIDE PANEL. OUTER LEFT SIDE PANEL	2	2	2							2	2	2						
	70501091 70501092	OUTER RIGHT SIDE PANEL. OUTER LEFT SIDE PANEL				2	2	2							2	2	2			
	70501086 70501087	OUTER RIGHT SIDE PANEL. OUTER LEFT SIDE PANEL							2	2	2							2	2	2
4	33976	CONTROL PANEL	1	1	1															
	33952	CONTROL PANEL				1	1	1												
	33993	CONTROL PANEL							1	1	1									
	70502096	CONTROL PANEL										1	1	1						
	70502097	CONTROL PANEL													1	1	1			
	70502098	CONTROL PANEL																1	1	1
5	58269	CONTROL DECAL	1	1	1															
	58270	CONTROL DECAL				1	1	1												
	58271	CONTROL DECAL							1	1	1									
	58273	CONTROL DECAL										1	1	1						
	58274	CONTROL DECAL													1	1	1			
	58275	CONTROL DECAL																1	1	1
6	69145	THERMOMETER	1	1	1	2	2	2	3	3	3									
	70101034	DIGITAL CONTROLLER 120V										1			2			3		
	70101035	DIGITAL CONTROLLER 240V											1	1		2	2		3	3
	70101026	TEMPERATURE PROBE (120V/240V)										1	1	1	2	2	2	3	3	3
7	69121	THERMOSTAT	1	1	1	2	2	2	3	3	3									
8	56508	KNOB	1	1	1	2	2	2	3	3	3									
9	1509600	PILOT LIGHT	1	1	1	2	2	2	3	3	3									
10	33858	DRAWER SLIDE ROLLER	6	6	6	12	12	12	18	18	18	6	6	6	12	12	12	18	18	18
11	89013	MACHINE SCREW	6	6	6	12	12	12	18	18	18	6	6	6	12	12	12	18	18	18
12	8353200	RIVNUT	8	8	8	16	16	16	24	24	24	8	8	8	16	16	16	24	24	24
13	8945500	LOOP CLAMP S/S	1	1	1	2	2	2	3	3	3	1	1	1	2	2	2	3	3	3
14	30203	TERMINAL BLOCK	1	1	1	1	1	1	1	1	1	1	1	1	1	1	1	1	1	1
15	60113	INSULATION 21X19X1	4	4	4	6	6	6	9	9	9	4	4	4	6	6	6	9	9	9
16	70501078	FRONT PLATE	1	1	1							1	1	1						
	70501088	FRONT PLATE				1	1	1							1	1	1			
	70501084	FRONT PLATE							1	1	1							1	1	1

PARTS LIST(QTY'S)

ITEM	PN	DESCRIPTION	HDDIS-1			HDDIS-2			HDDIS-3			HDXIS-1			HDXIS-2			HDXIS-3		
			120	208	240	120	208	240	120	208	240	120	208	240	120	208	240	120	208	240
19	84559	HOLE PLUG	1	1	1	1	1	1	1	1	1	1	1	1	1	1	1	1	1	
20	70501080	OUTER BACK PANEL	1	1	1							1	1	1						
	70501090	OUTER BACK PANEL				1	1	1						1	1	1				
	70501085	OUTER BACK PANEL							1	1	1						1	1	1	
21	70501057	TOP BRACE ASSY	1	1	1	1	1	1	1	1	1	1	1	1	1	1	1	1	1	
22	33975	RIGHT SIDE BRACE	1	1	1							1	1	1						
	33951	RIGHT SIDE BRACE				1	1	1						1	1	1				
	33992	RIGHT SIDE BRACE							1	1	1						1	1	1	
23	70502072	RIGHT SIDE DRAWER SLIDE	1	1	1	2	2	2	3	3	3	1	1	1	2	2	2	3	3	3
24	70502073	LEFT SIDE DRAWER SLIDE	1	1	1	2	2	2	3	3	3	1	1	1	2	2	2	3	3	3
25	70502077	STANDARD PAN 12X20	1	1	1	2	2	2	3	3	3	1	1	1	2	2	2	3	3	3
26	88987	SCREW, 1/4-20X3/4"	2	2	2	4	4	4	6	6	6	2	2	2	4	4	4	6	6	6
27	70502042	FLAT ROLLER BEARING	2	2	2	4	4	4	6	6	6	2	2	2	4	4	4	6	6	6
28	70501076	CENTER PAN SUPPORT ASSY	1	1	1	2	2	2	3	3	3	1	1	1	2	2	2	3	3	3
29	55613	HANDLE (ALSO NEED 30&31)	1	1	1	2	2	2	3	3	3	1	1	1	2	2	2	3	3	3
30	8164100	SCREW, 10-24X1"	2	2	2	4	4	4	6	6	6	2	2	2	4	4	4	6	6	6
31	89070	WASHER, #10 INTERNAL TEETH	2	2	2	4	4	4	6	6	6	2	2	2	4	4	4	6	6	6
32	70503200	DRAWER ASSY (INCLUDES 25-31)	1	1	1	2	2	2	3	3	3	1	1	1	2	2	2	3	3	3
N/A	70502045	WIRE SET	1	1	1							1	1	1						
N/A	70502047	WIRE SET				1	1	1						1	1	1				
N/A	70502049	WIRE SET							1	1	1							1	1	1
N/A	70503000	MANUAL	1	1	1	1	1	1	1	1	1	1	1	1	1	1	1	1	1	1

APW Wyott EQUIPMENT LIMITED WARRANTY

APW Wyott Foodservice Equipment Company warrants its equipment against defects in materials and workmanship, subject to the following conditions:

This warranty applies to the original owner only and is not assignable.

Should any product fail to function in its intended manner under normal use within the limits defined in this warranty, at the option of APW Wyott such product will be repaired or replaced by APW Wyott or its Authorized Service Agency. APW Wyott will only be responsible for charges incurred or service performed by its Authorized Service Agencies. The use of other than APW Wyott Authorized Service Agencies will void this warranty and APW Wyott will not be responsible for such work or any charges associated with same. The closest APW Wyott Authorized Service Agent must be used.

This warranty covers products shipped into the 48 contiguous United States, Hawaii, metropolitan areas of Alaska and Canada. There will be no labor coverage for equipment located on any island not connected by roadway to the mainland.

Warranty coverage on products used outside the 48 contiguous United States, Hawaii, and metropolitan areas of Alaska and Canada may vary. Contact the international APW Wyott distributor, dealer, or service agency for details.

Time Period

One year for parts and one year for labor, effective from the date of purchase by the original owner. The Authorized Service Agency may, at their option, require proof of purchase. Parts replaced under this warranty are warranted for the un-expired portion of the original product warranty only.

Exceptions

- * Gas/Electric Cookline: Models GCB, GCRB, GF, GGM, GGT, CHP-H, EF, EG, EHP. Three (3) Year Warranty on all component parts, except switches and thermostats. (2 additional years on parts only. No labor on second or third year.)
- * Broiler Briquettes, Rock Grates, Cooking Grates, Burner Shields, Fireboxes: 90 Day Material Only. No Labor.
- * Heat Strips: Models FD, FDL, FDD, FDDL. Two (2) Year Warranty on element only. No labor second year.
- * Glass Windows, Doors, Seals, Rubber Seals, Light Bulbs: 90 Day Material Only. No Labor.

In all cases, parts covered by extended warranty will be shipped FOB the factory after the first year.

Portable Carry In Products

Equipment weighing over 70 pounds or permanently installed will be serviced on-site as per the terms of this warranty. Equipment weighing 70 pounds or under, and which is not permanently installed, i.e. with cord and plug, is considered portable and is subject to the following warranty handling limitations. If portable equipment fails to operate in its intended manner on the first day of connection, or use, at APW Wyott's option or its Authorized Service Agency, it will be serviced on site or replaced.

From day two through the conclusion of this warranty period, portable units must be taken to or sent prepaid to the APW Wyott Authorized Service Agency for in-warranty repairs. No mileage or travel charges are allowed on portable units after the first day of use. If the customer wants on-site service, they may receive same by paying the travel and mileage charges. Exceptions to this rule: (1) countertop warmers and cookers, which are covered under the Enhanced Warranty Program, and (2) toasters or rollergrills which have in store service.

Exclusions

The following conditions are not covered by warranty:

- * Equipment failure relating to improper installation, improper utility connection or supply and problems due to ventilation.
- * Equipment that has not been properly maintained, calibration of controls, adjustments, damage from improper cleaning and water damage to controls.
- * Equipment that has not been used in an appropriate manner, or has been subject to misuse or misapplication, neglect, abuse, accident, alteration, negligence, damage during transit, delivery or installation, fire, flood, riot or act of god.
- * Equipment that has the model number or serial number removed or altered.

If the equipment has been changed, altered, modified or repaired by other than an Authorized Service Agency during or after the warranty period, then the manufacturer shall not be liable for any damages to any person or to any property, which may result from the use of the equipment thereafter.

This warranty does not cover services performed at overtime or premium labor rates. Should service be required at times which normally involve overtime or premium labor rates, the owner shall be charged for the difference between normal service rates and such premium rates. APW Wyott does not assume any liability for extended delays in replacing or repairing any items beyond its control.

In all cases, the use of other than APW Wyott Authorized OEM Replacement Parts will void this warranty.

This equipment is intended for commercial use only. Warranty is void if equipment is installed in other than commercial application.

Water Quality Requirements

Water supply intended for a unit that has in excess of 3.0 grains of hardness per gallon (GPG) must be treated or softened before being used. Water containing over 3.0 GPG will decrease the efficiency and reduce the operation life of the unit.

Note: Product failure caused by liming or sediment buildup is not covered under warranty.

“THE FOREGOING WARRANTY IS IN LIEU OF ANY AND ALL OTHER WARRANTIES EXPRESSED OR IMPLIED INCLUDING ANY IMPLIED WARRANTY OF MERCHANTABILITY OR FITNESS FOR PARTICULAR PURPOSES AND CONSTITUTES THE ENTIRE LIABILITY OF APW WYOTT. IN NO EVENT DOES THE LIMITED WARRANTY EXTEND BEYOND THE TERMS STATED HEREIN.”

9/05