

CONNECTIONS	
INLET	3/4" BSP.
OUTLET	3/4" BSP.
DRAIN	14 mm OD. HOSE TAIL
OVERFLOW	14 mm OD. HOSE TAIL

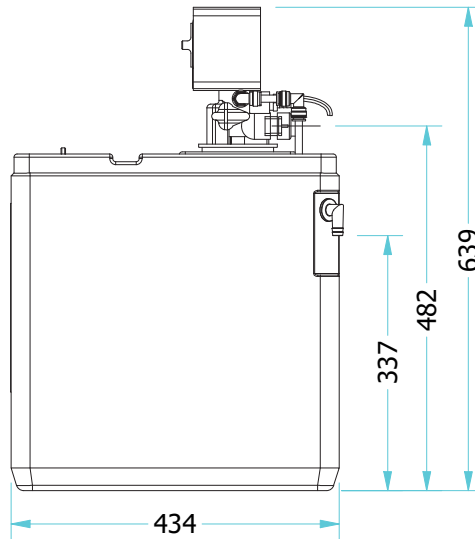

HOT WATER SOFTENER INSTALLATION REQUIREMENTS	
WATER PRESSURE	MIMIMUM 1.5 BAR / MAXIMUM 3 BAR.
WATER TEMPERATURE	MAXIMUM 50 DEG CELSIUS - PROTECT FROM FREEZING.
ELECTRICAL SUPPLY	24/240 V VAC3 AMP MAINTAINED POWER SUPPLY
CAPACITY	1494 LTRS (@ 286 PPM HARDNESS)

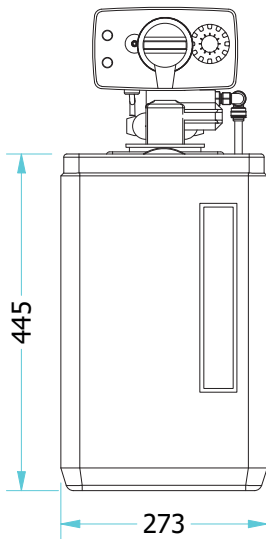

EUROPEAN WATERCARE LTD
REGAL HOUSE, SOUTH ROAD
HARLOW, CM20 2BL
ESSEX, ENGLAND
TEL: +44 (0) 1279 780 250

EUROPEAN WATERCARE LTD
This drawing and its contents are the exclusive property of European Watercare Ltd and may not be used, copied or disclosed to any third party without the express written permission of European Watercare Ltd. It must be returned immediately upon request.

APPR. BY:
APPR. DATE:
SCALE:
JOB No: 001
DRAWN BY: RM
DATE: 11/01/2020
SHEET SIZE: A4

REV. | P |



THIRD ANGLE PROJECTION

TITLE:
PH10 - 10 LTR HOT WATER SOFTENER
EUROPEAN WATERCARE

SHEET NUMBER: 1 OF 1

DRAWING No. PH10