

50Hz

iT0420 Ice Cube Machine

iT0420 Ice Cube Machine

Models

- IDT0420A IYT0420A



Indigo NXT Series iT420 Ice Machine on D320 Bin

Designed for operators who know that ice is critical to their business, the Indigo NXT Series ice machine's preventative diagnostics continually monitor itself for reliable ice production. Improvements in cleanability and programmability make your ice machine easy to own and less expensive to operate.

- **New levels of Performance** – Showcasing an average increase of 65% in ice production, 26% reduction in energy usage and 21% reduction in potable water usage. This translates into lower cost of ownership over the life of your machine.
- **easyTouch[®] Display** - New icon based touch screen takes the guess work out of owning and operating an ice machine.
- **Multiple Language Capability** - The easyTouch display is available in multiple languages selected in the initial start-up installation Wizard.
- **Programmable Ice Production** – Now its super easy to program your ice machine to be off at certain times of the day to save money with fluctuating electrical rates. Also programmable by daily ice production volume.
- **Easy to Clean Foodzone** – Hinge front door swing out for easy access. Removable water-trough, distribution tube, curtain, water probe and water pump for fast and efficient cleaning. Selected components are made with AlphaSan[®] antimicrobial.
- **Intelligent Diagnostics** – Provides 24 hour preventative maintenance and diagnostic feedback for trouble free operation.
- **Acoustical Ice Sensing Probe** – Unique patented technology allows for reliable operation in challenging water conditions and environments
- **DuraTech[®] Exterior** – Provides superior corrosion resistant above stainless steel. Innovative clear-coat resists fingerprints and dirt making it easier to keep clean.
- Available **Luminice[®] II Growth Inhibitor** – Controls the growth of bacteria and yeast within the Food zone keeping the machine cleaner longer. A new indicator in the display keeps you abreast of the operational status.

Ice Machine Electric

230/50 /1

Minimum circuit ampacity:

Air-cooled: 5.7

Maximum fuse size:

Air-cooled: 15 1ph



Specifications

BTU Per Hour:
3,800 (average),
and 6,000 (peak)

Refrigerant:

R410A - CFC Free
Lowers global warming
by 48%

Operating Limits:

- Ambient Temperature Range: 40° to 110° F (4.4° to 43.3° C)
Water Temperature Range: 40° to 90° F (4.4° to 32.2° C)
- Water Pressure Ice Maker Water In:
Min. 20 psi (137.9 kPa)
Max. 80 psi (551.1 kPa)

Ice Shape



Half Dice
3/8" x 1 1/8" x 7/8"
(.95 x 2.86 x 2.22 cm)
Cube weight 5.7 g



Dice
7/8" x 7/8" x 7/8"
(2.22 x 2.22 x 2.22 cm)
Cube weight 8.5 g



COMPANY WITH
QUALITY SYSTEM

Welbilt Deutschland GmbH
Auf der Weih 11
D - 35745 Herborn, Germany
Tel.: +49 27 72 58 050
welbilt.com.de

Welbilt Iberia, S.A.U
Textil, 6 - Pol.Ind. La Ferreria - 08110
Montcada i Reixac
Barcelona, Spain
Tel.: +34 902 20 10 69
welbilt.com.es

Welbilt UK
Ashbourne House The Guildway,
Old Portsmouth Rd Guildford GU3
1LR United Kingdom
Tel.: +44 1483 464900
www.welbilt.uk





50Hz

Indigo® NXT™ iT0420 Ice Cube Machine

iT0420 on D-320 Storage Bin

- Ⓐ Electrical Entrance (2) Options
- Ⓑ 3/8" (0.95 cm) F.P.T. Water Condenser Inlet (water-cooled units)
- Ⓒ 1/2" (1.27 cm) F.P.T. Water Condenser Outlet (water-cooled units)
- Ⓓ 1/2" (1.27 cm) Auxiliary Base Drain Socket
- Ⓔ 3/8" (0.95 cm) F.P.T. Ice Making Water Inlet
- Ⓕ 1/2" (1.27 cm) F.P.T. Ice Making Water Drain
- Ⓖ 3/4" (1.91 cm) Bin Drain

Installation Note
Minimum installation clearance:
Top/side: 12" (30.50 cm)
Back is 5" (12.7 cm)

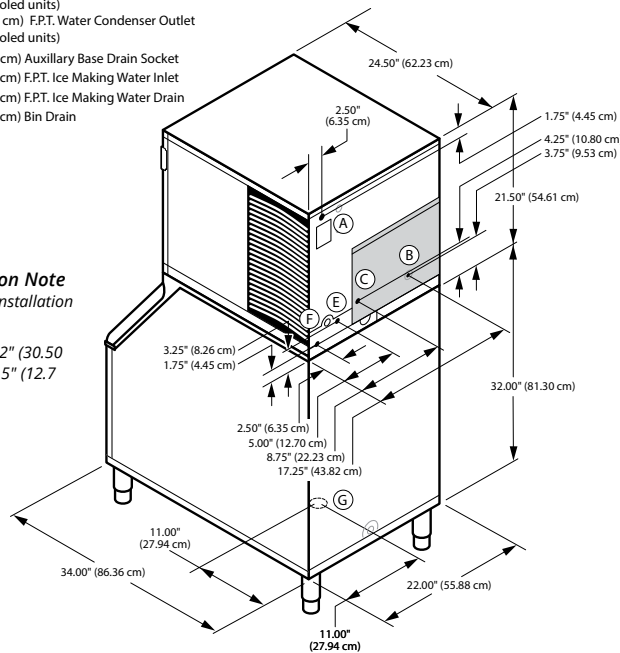

Space-Saving Design



	iT0420 D-320	iT0420 D-420
Height	59.50"	71.50"
	151.13 cm	181.61 cm
Width	22.00"	22.00"
	55.88 cm	55.88 cm
Depth	34.00"	34.00"
	86.30 cm	86.30 cm
Bin	264 lbs.	383 lbs.
Storage	118 kgs.	174 kgs.

Height includes adjustable bin legs 6.00" to 8.00", (15.24 to 20.32 cm) set at 6.00" (15.24 cm).
Bin capacity is based on 90% of the volume x 33 lbs/ft³ average density of ice.

Specifications

	Model	Ice Shape	Ice Production 24 Hours		Power Usage	Potable Water Usage/100 lbs. 45.4 kgs. of Ice
			21°Air / 10°C Water 70°Air/ 50°F Water	32°Air / 21°C Water 90°Air/ 70°F Water	kWh 45.4 kg / 100 lbs @ 32°Air / 21°C Water 90°Air / 70°F Water	
AIR COOLED	IDT0420A	dice	450 lbs.	360 lbs.	1 Ph	19 Gal.
			204 kgs	163 kgs	5,6	72 L
	IYT0420A	half-dice	450 lbs.	360 lbs.	5,4	19 Gal.
			204 kgs	163 kgs		72 L

Order separately: Ice storage bin for all units
This product is hermetically sealed and contains fluorinated greenhouse gas R410A

Accessories

LuminIce® II Growth Inhibitor
reduces yeast and bacteria growth for a cleaner ice machine.



External Scoop holder

Protect the ice scoop with the NSF approved versatile scoop holder.

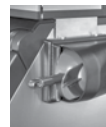

Arctic Pure® Water Filters

Reduces sediment and chlorine odors for better tasting ice.



Welbilt reserves the right to make changes to the design or specifications without prior notice.

Welbilt Deutschland GmbH
Auf der Weih 11
D - 35745 Herborn, Germany
Tel.: +49 27 72 58 050
welbilt.com.de

Welbilt Iberia, S.A.U
Textil, 6 - Pol.Ind. La Ferreria - 08110
Montcada i Reixac
Barcelona, Spain
Tel.: +34 902 20 10 69
welbilt.com.es

Welbilt UK
Ashbourne House The Guildway,
Old Portsmouth Rd Guildford GU3
1LR United Kingdom
Tel.: +44 1483 464900
www.welbilt.uk

