



F54/730 - IMC Vulture 904 Floor-mounted Food Waste Disposer - 1 Phase [air break] - W 438 mm - 1.1 kW

Reliable, efficient, safe and easy to operate, the 904 Waste Disposer allows operators to quickly and effectively remove waste, to create a safer and cleaner kitchen.

- ✓ Fast and efficient disposal of up to 500kg of food waste per hour.
- ✓ Manually reversible motor to extend operational life.
- ✓ Handles up to 1000 covers per sitting - ideal for large kitchens.
- ✓ With class A airbreak kit - recommended when connecting to a mains water supply.
- ✓ For medium waste (plate waste, vegetables and peelings, meat and fish scraps).
- ✓ Suitable for large kitchens with single-phase power supply.
- ✓ Free-standing design, but can be welded into tabling with E30/095 hopper rim.

Specifications

Summary

Brand	IMC
Range	Vulture
Series	04 Series
Power Type	Electric
Unit Type	Floor-mounted or welded into tabling [with optiona
Available in UK Only	No
UK Warranty	2 Years Parts and Labour Warranty
Export Warranty	Contact your local dealer
Mounting	Floor-mounted
GTIN	5056105199397

Power and Performance

Total Power kW	1.1
HP	1.5
IP Rating	IP55

Key Specifications

Operator Safety	Interlocks
Airbreak	Yes

Capacity

Type of Waste	Medium waste
Covers Per Sitting	1000
Capacity Kg per Hour	500

Weights and Dimensions

Unit Height (External) mm	942
Unit Width (External) mm	438
Unit Depth (External) mm	564
Net Weight Kg	51.5

Supply Connections

Requires Installation	Yes
Requires Electrical Supply	Yes
UK 3 Pin Plug	No
Requires Hardwiring	Yes
Electrical Supply Rating Watts	1100
Single Phase Amps	7.4
Single Phase Voltage	230
Water Supplied From	Mains or storage cistern
Water Connection Pressure Bar	0.4
Drain Connection	2" BSP threaded flange, connected to 54mm piping;
Water Connection	15mm

Shipping

Packed Weight Kg	56.65
Packed Height cm	104
Packed Width cm	62
Packed Depth cm	48

Available Options

REMOTE CONTROL BOX

S55/016 904 REMOTE CONTROL BOX

MAG CUTLERY SAVER

VS167 700/800/904/904X MAGNETIC CUTLERY SAVER

WATER FLOW CONTROL

VS353 904 WATER FLOW CONTROL

Available Accessories

E30/095 Hopper Rim for 904/904X Food Waste Disposer

Technical Picture

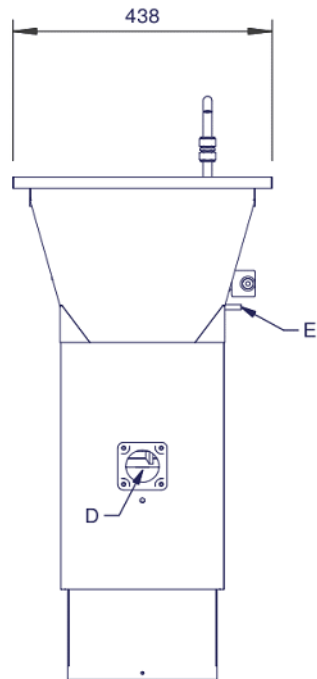
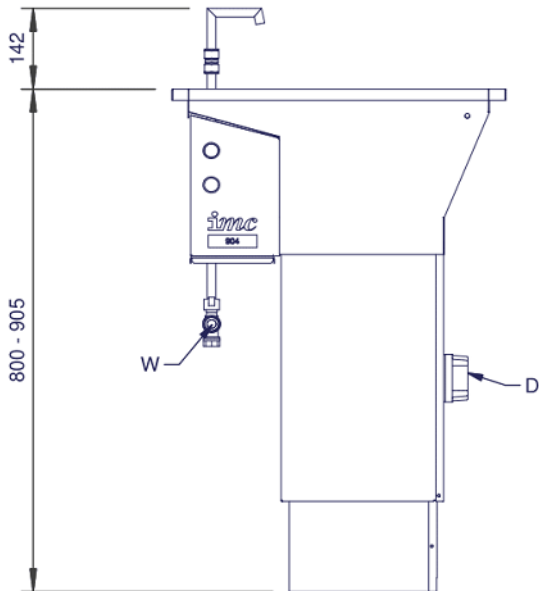
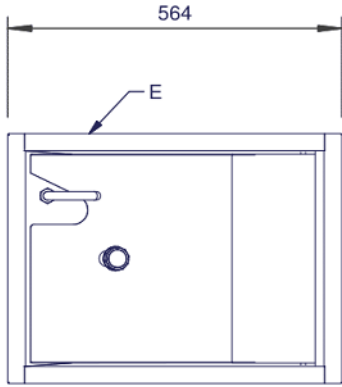

Lincat Limited

Whisby Road,
Lincoln, LN6 3QZ,
United Kingdom

Company No: 2175448

A member company of



Customer Care

Tel: +44 1522 875500
Email: care@lincat.co.uk

Export Customers

Tel: +44 1522 875536
Email: export@lincat.co.uk

Opening Hours

Monday – Friday:
8.30am – 5pm