



F58/902 - IMC SP12H Floor-mounted Potato Peeler - 1 Phase - H 1400 mm - 0.37 kW

The efficient, upright IMC Potato Peeler ensures short preparation times which in turn reduces costly wage bills and makes for better staff utilisation.

- ✓ Upright design - ideal for medium and large scale operations
- ✓ Perfect height to empty into a sink
- ✓ Hygienic and easy to clean
- ✓ WRAS approved Class A air-break and brass spray nozzle prevents any back siphonage of water into the mains supply
- ✓ Reversible corrosion-proof liners
- ✓ Dual position for waste outlet
- ✓ 2 minutes to peel a batch of 12 kilos of potatoes
- ✓ Single phase

Specifications

Summary		Power and Performance	
Brand	IMC	Total Power kW	0.37
Range	SP Peeler	HP	0.5
Power Type	Electric	IP Rating	IP55
Unit Type	Floor-mounted		
Available in UK Only	No		
UK Warranty	2 Years Parts and Labour Warranty		
Export Warranty	Contact your local dealer		
Mounting	Floor-mounted		
GTIN	5056105198796		

Key Specifications		Capacity	
Operator Safety	User Guide	Capacity Kg per Hour	220
Timer	Yes		
Drain Location	Right or left		
Airbreak	Yes		

Weights and Dimensions		Supply Connections	
Unit Height (External) mm	1388	Requires Installation	Yes
Unit Width (External) mm	530	Requires Electrical Supply	Yes
Unit Depth (External) mm	624	UK 3 Pin Plug	Yes
Net Weight Kg	50.5	Requires Hardwiring	No
		Motor Rating Watts	370
		Single Phase Amps	6.2
		Single Phase Voltage	230
		Water Connection Pressure Bar	2.7-3.8 [40-55 psi]
		Drain Connection	54mm
		Water Connection	12mm

Shipping	
Packed Weight Kg	55.55
Packed Height cm	148
Packed Width cm	68
Packed Depth cm	57

Available Accessories

Available Accessories

- S58/568** Filter Basket - Integral - for SP Potato Peeler
- S58/569** Interceptor Tank - for SP Potato Peeler [pedestal mounted/2" BSP]
- S58/570** Waste Ejector for SP Potato Peeler [2" BSP]

Technical Picture

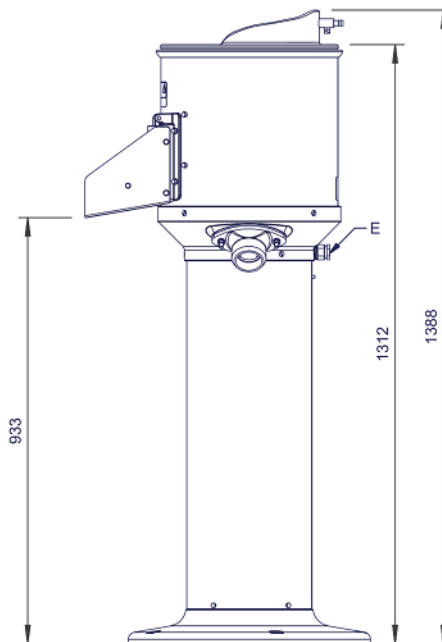
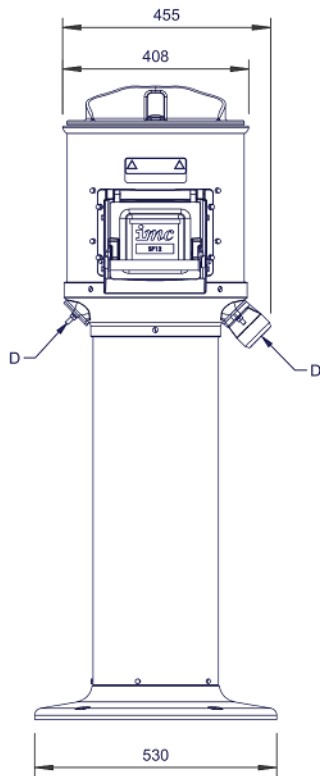
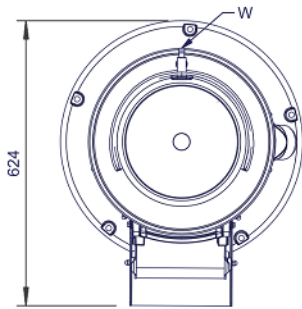



Lincat Limited

Whisby Road,
Lincoln, LN6 3QZ,
United Kingdom

Company No: 2175448

A member company of



Customer Care

Tel: +44 1522 875500
Email: care@lincat.co.uk

Export Customers

Tel: +44 1522 875536
Email: export@lincat.co.uk

Opening Hours

Monday – Friday:
8.30am – 5pm