

**LYNX 32**

**VACUUM PACKAGING MACHINE**



**DESCRIPTION**

The state-of-the-art Lynx 32 vacuum packaging machine is standard equipped with a Busch vacuum pump, Advanced Control System which is label printer compatible, Sensor control that ensures an optimum vacuum every cycle, and special marinating and packaging functions. This table-top model complies with CE standards.



Henkelman offers standard 3 year warranty.

**FEATURES**

- Standard with 1 seal bar (front): 320 mm
- Standard double seal (two wires). Optional without extra costs: Cut-off/Wide seal
- Seal bars easily removable for cleaning and maintenance purposes
- Pump capacity: 8 m<sup>3</sup>/h Busch vacuum pump
- Pump maintenance and cleaning program
- Machine cycle: 15-30 sec
- Standard Sensor control: max. 99.8%, for an optimum and consistent vacuum and cycle time
- Standard Soft Air to protect the product and vacuum bag
- Standard Advanced Control System with 20 program memory and Sensor control
- Stainless steel flat work plate and a transparent lid
- Comes with insert plate for a faster cycle and product adjustment
- Stainless steel exterior

**OPTIONS**

- Liquid control
- Gas flush
- High Temp to vacuum pack products at a high temperature

**ACCESSORIES**

- Zebra ZD410 thermal label printer
- Inclined insert plate (for packing liquids)
- Food container adaptor
- Service kit for standard maintenance
- Trolley with shelve

# VACUUM PACAGING MACHINE LYNX 32 – SPECS

## DIMENSIONS

In mm

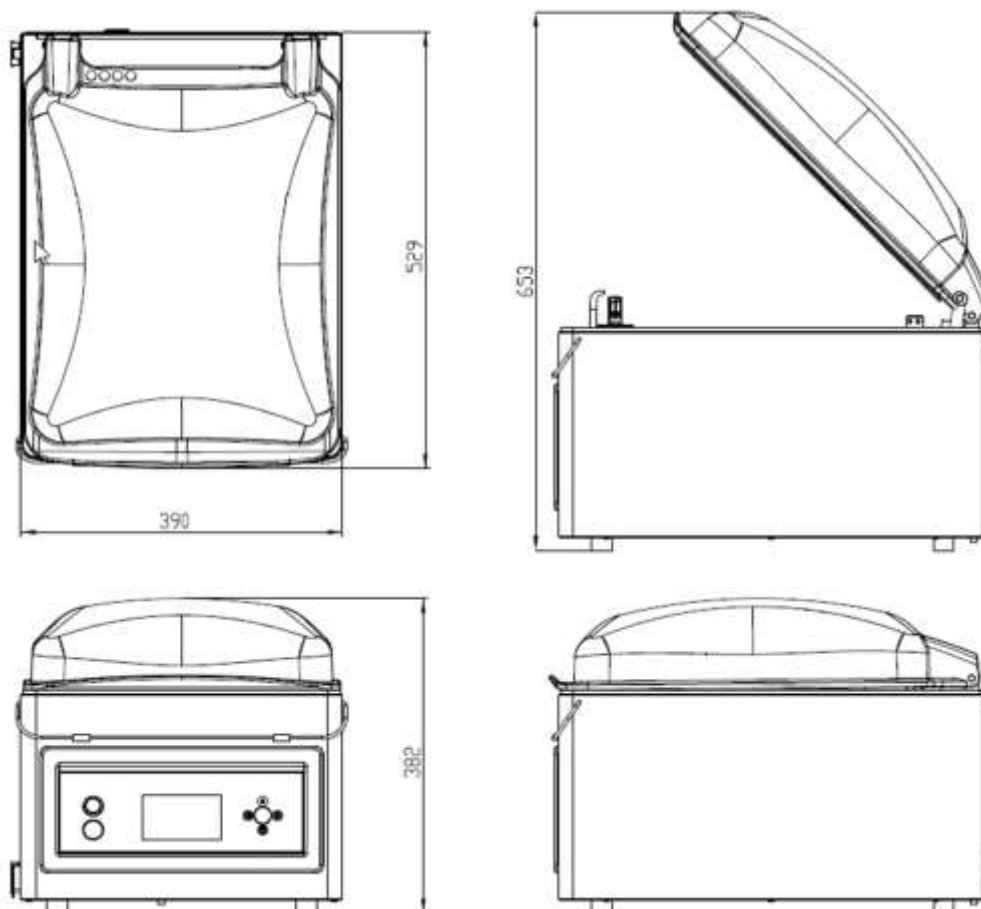

Model	Dimensions (mm)		Voltage* (Hz)	Pump capacity (m3/h)	Power (kW)	Weight (kg)
	Chamber (usable space) L x W x H	Machine L x W x H				
Lynx 32	360 x 320 x 103	529 x 390 x 382	230V-1-50	8	0,5	43

\* Other voltages available



HENKELMAN BV  
Titaniumlaan 10  
5221 CK 's-Hertogenbosch  
The Netherlands

**Sales support**  
P +31 73 621 36 71  
E [info@henkelman.com](mailto:info@henkelman.com)  
**Service/technical support**  
P +31 73 621 36 71  
E [service@henkelman.com](mailto:service@henkelman.com)