



Model

NS350A

Product Description

Slicer, 14", Automatic, Heavy Duty

Product Code

5S515N



Standard Features

- Automatic slicer designed to cut large quantities of food. Suited to large restaurants, supermarkets, delis, butchers and central production kitchens / canteens, where high volume of meat types is required, and precise control of the automatic slicing feature is necessary
- Two independent motors (one for blade and one for carriage movement)
- Can be used as a fully automatic slicer or switches to manual
- Simple, intuitive touch control panels allow for the selection of multiple slicing options
- Optional slice counter available
- Hollow ground chromed carbon steel blade
- Easy set thickness control allows for precision slicing
- Made from high polished, anodised food grade aluminium for durability and hygiene
- Large base to ensure slicer has a large capacity to cope with large products
- Ergonomic design with smooth rounded edges to allow for fast and easy cleaning and improved levels of hygiene
- Fully interlocked and safe guarded for full compliance of CE legislation. This ensures all-round blade protection for the ultimate user safety during cleaning
- Built-in, self-aligning sharpening and de-burring unit
- Table / carriage, blade cover, blade and sharpening unit are detachable for easy, safe cleaning
- Optional voltages and frequencies available on request
- CE Approved

Standard Accessories

- 1 x Knife Remover
- 1 x Flat Head Screwdriver
- 1 x Tasteless Oil

Warranty

Covered by Metcalfe 2-year warranty (1st year parts and labour, 2nd year parts only) and full after sales service

Optional Accessories

Item
Tray Extension Device
Stainless Steel Guard
Product Hold Bar for Gravity Plate
Slice Counter

Item
Serrated Blade
Teflon Coated Parts (Blade Cover, Gauge Plate, Blade)
Special Arm (Protected)
Painting Customisation

Item
Stainless Steel Knife Remover
Aluminium Knobs
Plastic Cover – Medium
Vegetable Tube

Drawing

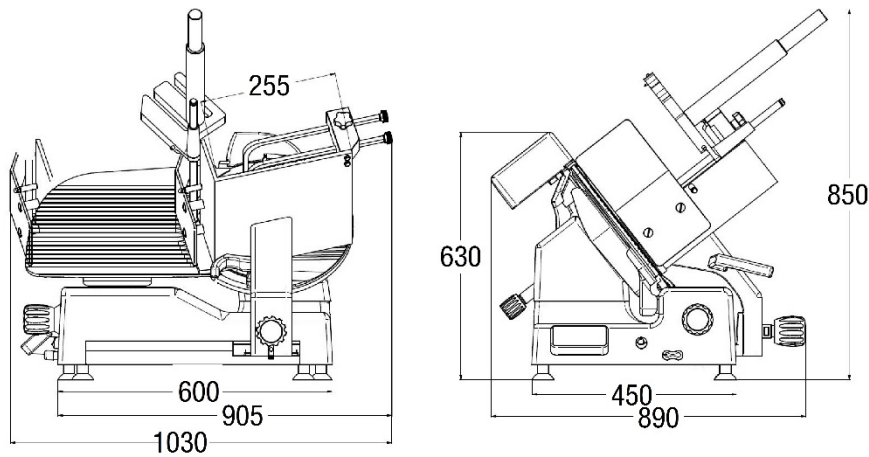

Specifications

Model	Blade (mm) / (Inch)	Phase (Ø)	Motor (Volt)	Frequency (Hz)	Current (Amp)	Power (kW)
NS350A	350 / 14	1	220	50	2.59	0.57

Capacity

Model	Cutting Capacity (mm)	Carriage Movement (mm)	Max Slice Thickness (mm)	Slices Per Min
NS350A	● 260 □ 210 x 275	365	20	Min 25 – Max 86

Dimensions | Shipping Information

Model	Overall Dimensions D x W x H (mm)	Net Weight (kg)	Packed Dimensions D x W x H (mm)	Packed Weight (kg)	Volume (m3)
NS350A	890 x 1030 x 850	50	720 x 840 x 760	57	0.46

We reserve the right to alter the specification and technical details for this item at any time without prior notice. 10/2020

Metcalfe Catering Equipment Ltd

Haygarth Park
Blaenau Ffestiniog
Gwynedd, LL41 3PF

