



# IMMERSION BLENDER & WHISK COMBO MB-51 230/50-60/1

Professional hand blender and beater. 570 W.



3030826

DYNAMIC PREPARATION  
COMMERCIAL HAND BLENDERS



## SALES DESCRIPTION

- ✓ Variable speed motor block.
- ✓ 425 mm detachable mixer arm designed for continuous use in recipients of up to 80 l.
- ✓ Whisk with capacity for 2 to 80 egg whites.

### All-in-one

- ✓ Professional hand blender and beater.
- ✓ Professional hand blender designed for carrying out different preparations without the need for add-on tools.
- ✓ Professional Y-blade, made from tempered steel and with a long-duration cutting edge.
- ✓ Vario-speed: variable speed.
- ✓ Mixer arm designed to work in recipients of up to 80 litres.
- ✓ Beater with capacity for 2 to 100 egg whites.

### Maximum comfort for the user

- ✓ Logical and manageable size.
- ✓ Ergo-design & bi-mat-grip: external casing made in two materials for an ergonomic hold. Anti-slip grip. Optimum inclination of handle, minimising fatigue.
- ✓ Click-on-arm: detachable arm with fast and secure closure.
- ✓ Mixer arm hood designed to avoid splashes.
- ✓ Intuitive use: very simple operation. LED warning light in two colours to indicate the status of the machine.
- ✓ Possibility of continuous operation.

### Built to last

- ✓ Professional performance: capable of carrying out prolonged work without the casing overheating.
- ✓ Life-plus: equipped with a motor which has passed all of the most demanding usage tests.
- ✓ Studied geometry: casing designed to avoid rolling and falling.
- ✓ Easy to clean: detachable arms, can be cleaned under the tap.
- ✓ Approved by NSF: guaranteed safety and hygiene.

## INCLUDES

- ✓ Variable speed motor block.
- ✓ Whisk BA-50.
- ✓ MA-51 mixer arm.
- ✓ Wall mount.

## OPTIONAL

- MA-52 mixer arm.
- Clamp sliding frame.
- "Quick fix" clamp.

## ACCESSORIES

- Clamp sliding frame
- "Quick fix" bowl clamp

## SPECIFICATIONS

Total loading: 570 W  
 Electrical supply: 230 V / 50-60 Hz / 1 ~ (3.2 A)  
 Plug: UK (BS 1363 10A / 2P)

### Liquidiser function

Maximum recipient capacity: 80 l  
 Maximum working depth: 284.5 mm  
 vel\_tri\_min - vel\_tri\_max: 1500 - 12000 rpm  
 Blade diameter: 60 mm  
 Blade guard diameter: 101 mm  
 Liquidising arm length: 425 mm  
 Total length: 765 mm

### Whisk function

vel\_bat\_min - vel\_bat\_max: 200 - 1500 rpm  
 Capacity (egg whites): 2 - 80  
 Revolving arm length: 405 mm  
 Total length (with revolving arm): 746 mm

Net weight: 4.65 Kg

Noise level (1m.): <80 dB(A)

### Crated dimensions

575 x 455 x 130 mm  
 Gross weight: 6.3 Kg





# IMMERSION BLENDER & WHISK COMBO MB-51 230/50-60/1

Professional hand blender and beater. 570 W.



3030826

DYNAMIC PREPARATION  
COMMERCIAL HAND BLENDERS

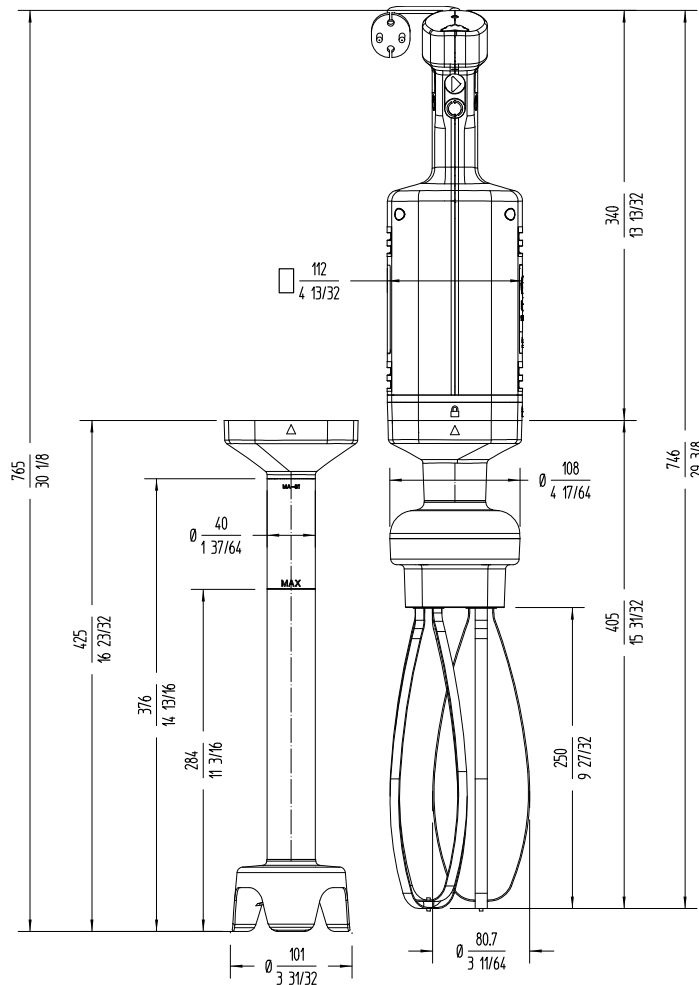

[www.sammic.co.uk](http://www.sammic.co.uk)

Food Service Equipment Manufacturer

Unit 2, Trevanth Road

Troon Industrial Park

LE4 9LS - Leicester

[uksales@sammic.com](mailto:uksales@sammic.com)

Tel.: +44 0116 246 1900



Project

Date

Item

Qty

Approved

product sheet  
updated 23/11/2022