

CHAP. 8 - SCRAPPING

8.1 - OUT OF SERVICE

If the appliance for some reason is to be put out of service, make sure it can no longer be used: **disconnect and remove all electrical connections.**

8.2 - WEEE Waste of Electric and Electronic Equipment



Directive 2002/95/EC, 2002/96/EC and 2003/108/EC on the restriction of the use of certain hazardous substances in electrical and electronic equipment, and waste electrical and electronic equipment.

This symbol, crossed out wheeled bin, on the product or on its packaging indicates that this product must not be disposed of with your other household waste.

Separate waste collection of this appliance is organised and managed by the manufacturer. It is the user's responsibility to contact the manufacturer and follow the waste treatment system the manufacturer has adopted for separate waste collection.

The separate collection and recycling of your waste equipment at the time of disposal will help to conserve natural resources and ensure that it is recycled in a manner that protects human health and the environment.

**SERVICE CENTRE
AUTHORISED DEALER**

OPERATING AND MAINTENANCE MANUAL

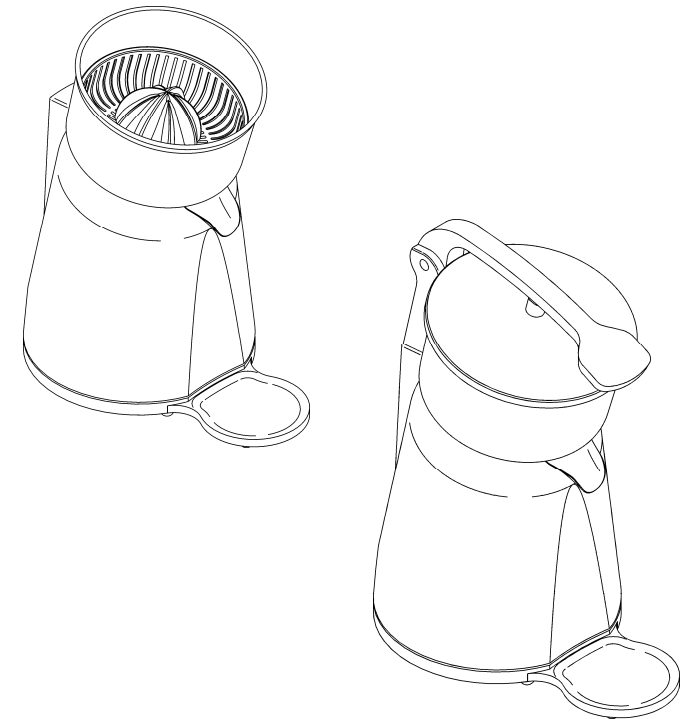

Ed. 10/2008

SQUEEZER

INTRODUCTION

- This instruction manual gives the customer all the necessary information about the appliance and the manufacturing standards applied, as well as all instructions for use and maintenance so that the appliance can be used correctly maintaining its efficiency in time.
- This instruction manual is for the end user and for service personnel.

INDEX

CHAP. 1 - INFORMATION ABOUT THE APPLIANCE	pag. 4
1.1 - GENERAL WARNINGS	
1.2 - SAFETY FEATURES INSTALLED	
1.2.1 - mechanical safety protections	
1.2.2 - electrical safety protections	
1.3 - APPLIANCE DESCRIPTION	
1.3.1 - general description	
1.3.2 - constructive characteristics	
1.3.3 - appliance elements	
CHAP. 2 - TECHNICAL DATA	pag. 6
2.1 - OVERALL DIMENSIONS, WEIGHT, CHARACTERISTICS ...	
CHAP. 3 - CONSIGNING THE APPLIANCE	pag. 7
3.1 - TRANSPORTING THE APPLIANCE	
3.2 - CHECKING PACKAGING UPON CONSIGNMENT	
3.3 - DISPOSING OF PACKAGING	
CHAP. 4 - INSTALLING THE APPLIANCE	pag. 7
4.1 - APPLIANCE LOCATION	
4.2 - CONNECTING TO ELECTRICITY SUPPLY	
4.3 - WIRING DIAGRAM	
4.4 - FUNCTIONAL CHECK	
CHAP. 5 - USING THE APPLIANCE	pag. 9
5.1 - CONTROLS	
5.2 - USING THE APPLIANCE	
CHAP. 6 - REGULAR CLEANING	pag. 10
6.1 - GENERALITIES	
6.2 - PROCEDURE TO FOLLOW FOR CLEANING THE APPLIANCE	
6.2.1 - cleaning the squeezer and juice container	

power circuit.

- switch the on/off switch (*ref.1 FIG. n°6*) to “0”;
- turn the knob (*ref.2 FIG. n°6*) to the minimum speed (**only for models VV**).

6.2 - PROCEDURE TO FOLLOW FOR CLEANING THE APPLIANCE

6.2.1 - cleaning the squeezer and juice container

To clean these two items proceed as follows:

- carefully remove the squeezer from the main structure;
- now remove the juice container.

Once these components have been removed wash them using warm water and a neutral detergent.

6.2.2 - general cleaning

N.B.: disconnect the electricity supply

To clean the main structure use neutral detergent and a damp cloth and remember to frequently rinse with clean water. Once all components are washed, dry them well.

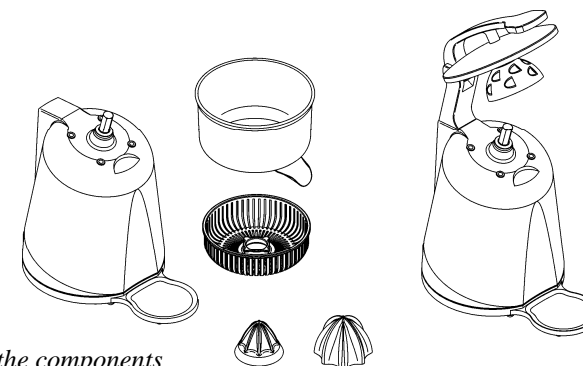

FIG.n°8 - Cleaning the components

CHAP. 7 - MAINTENANCE

7.1 - GENERALITIES

Before servicing the appliance **you must disconnect the electricity supply plug isolating the appliance from the main power source.**

7.2 - FOOT SUPPORTS

In time the foot supports can deteriorate losing their elastic properties causing instability. If this is the case replace them.

7.3 - POWER SUPPLY LINE

Periodically check wear in the power cable and if necessary contact the “SERVICE CENTRE” for a replacement.

LEVER MODEL

1. switch the start button to “I”;
2. raise the lever and place the citrus fruit with the cut half onto the strainer cone and lower the lever. The citrus fruit squeezer will start rotating;
3. continue until the citrus fruit is completely squeezed;
4. raise the lever and turn the citrus fruit squeezer off by switching the start button to “0”.

SPEED-CHANGE MODEL

1. switch the start button to “I”;
2. raise the lever and place the citrus fruit with the cut half onto the strainer cone and lower the lever. The citrus fruit squeezer will start rotating;
3. continue until the citrus fruit is completely squeezed;
4. raise the lever and turn the citrus fruit squeezer off by switching the start button to “0”;
5. To increase productivity turn the knob (ref. FIG. n°6) clockwise so as to just motor speed top the required speed.



FIG.n°7 - Correct position

CHAP. 6 - REGULAR CLEANING

6.1 - GENERALITIES

- the appliance must be cleaned at least once a day or if necessary more than once.
- scrupulously clean all the various components of the fruit-squeezer whether they come in direct contact with the food product or not.
- never clean the fruit-squeezer with a pressurised water-jet or industrial cleaner, brushes or any other type of cleaning utensil that could damage the surface of the appliance. Use water and a neutral detergent.

Before cleaning you must:

- a) remove the electricity supply plug isolating the appliance from the main

6.2.2 - general cleaning

CHAP. 7 - MAINTENANCE

pag. 11

7.1 - GENERALITIES

7.2 - FOOT SUPPORTS

7.3 - POWER SUPPLY CABLE

CHAP. 8 - SCRAPPING

pag. 12

8.1 - OUT OF SERVICE

8.2 - WEEE Waste of Electric and Electronic Equipment

CHAP. 1 - INFORMATION ABOUT THE APPLIANCE

1.1 - GENERAL WARNINGS

- The appliance must only be used by personnel who has carefully studied this manual and understood all the safety standards described herein.
- If there should be a turnover in personnel, it is necessary that this manual is carefully studied before using the appliance.
- Before cleaning or servicing the appliance, disconnect the electricity power supply.
- When cleaning or servicing the appliance (safety protections removed) take into consideration all possible hazards- Residual Risks.
- When servicing or cleaning the appliance always concentrate on what you are doing and avoid any possible distractions.
- Check the electricity power cable on a regular basis; a worn or damaged cable causes a dangerous electrical hazard
- If the appliance has a presumed malfunction or does not work correctly, do not use it or repair it. Contact the “Service Centre”.
- Do not use this appliance for frozen food products and non-food products
- The manufacturer cannot be held responsible for the following situations:
 - ⇒ if the appliance or safety devices are tampered with by unauthorised personnel
 - ⇒ if **non original** spare parts are used;
 - ⇒ if the instructions given in this manual are **not carefully and correctly** followed or respected;
 - ⇒ if unsuitable cleaning products are used to clean the appliance

1.2 - SAFETY FEATURES INSTALLED

1.2.1 - mechanical safety features

Regarding the mechanical safety features the appliance described herein conforms with the EU directives **EEC 2006/42**.

The safety protection is a micro-switch that activates the appliance when the squeezer is pressed.

1.2.2 - electrical safety features

Regarding electrical safety features, this appliance conforms to the EU directives **EEC 2006/95, 2004/108** and to standards **EEC EN 60335-1, EN 55014**.

Although the appliance is fitted out with electrical and mechanical safety protections that conform to the standards in force (these protections are for when the appliance is working and when it is being cleaned or serviced) there are however, **RESIDUAL RISKS** that cannot be completely eliminated and are indicated by the wording **CAUTION** in this manual. These risks refer to the risk of being cut or injured by sharp components.

4.4 - FUNCTIONAL CHECK

To check the appliance works correctly proceed as follows:

- 1 check that the appliance works when the squeezer is pressed;
- 2 for models VV check that the number of revs increase (*ref.2 FIG.n°6*), when the knob is turned.

CHAP. 5 - USING THE APPLIANCE

5.1 - CONTROLS

The controls for the citrus fruit-squeezer are shown in the below diagram.

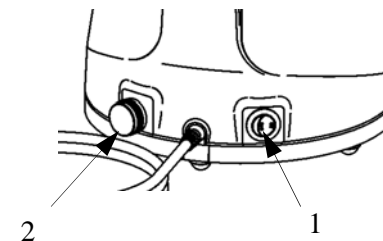

1 on/off switch:
position I start
position 0 stop
2 speed variator (mod. VV)

FIG. n°6 - Controls

5.2 - USING THE SQUEEZER

To squeeze the fruit follow the below instructions:

Always stand in the correct position to avoid accidents. Your body must be perpendicular to the work surface (*see FIG. n°7*); do not force any of the components with your hands or obstruct them in any way.

Be careful that your body or any part of it does not come in contact with the squeezer when working

STANDARD MODEL

1. place the citrus fruit with the cut half onto the strainer cone and press gently down;
2. switch the start button to “I” to turn the citrus fruit squeezer on;
3. continue until the citrus fruit is completely squeezed;
4. turn the citrus fruit squeezer off by switching the start button to “0”.

MIRCRO-SWITCH MODEL

1. switch the start button to “I”;
2. place the citrus fruit with the cut half onto the strainer cone and press gently down. The citrus fruit squeezer will start rotating;
3. continue until the citrus fruit is completely squeezed;
4. turn the citrus fruit squeezer off by switching the start button to “0”.

work surface must be level dry, smooth, solid and stable.

The appliance must be located in a non-salty environment with a max humidity value of 75% and with a temperature between +5° and +35°C; and however, always in areas and environments that do not cause any type of malfunction to the appliance.

4.4.2 - CONNECTING TO THE ELECTRICITY SUPPLY

The fruit-squeezer comes supplied with a 3 x 1,5 mm² section (thickness) and ≅ 1.5 m long power cable and with a SHUKO plug.

Connect the appliance to a 230V./50Hz power supply, interposing a differential -thermo magnetic switch type 10A, Δ I = 0.03A. At this point make sure the main earth circuit functions correctly.

Also check that the information given on the technical data and serial number plate (FIG. n°4) corresponds to the information given in the accompanying documents.

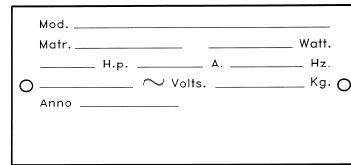

FIG. n°4 - Technical data & serial number plate

4.3 - WIRING DIAGRAM

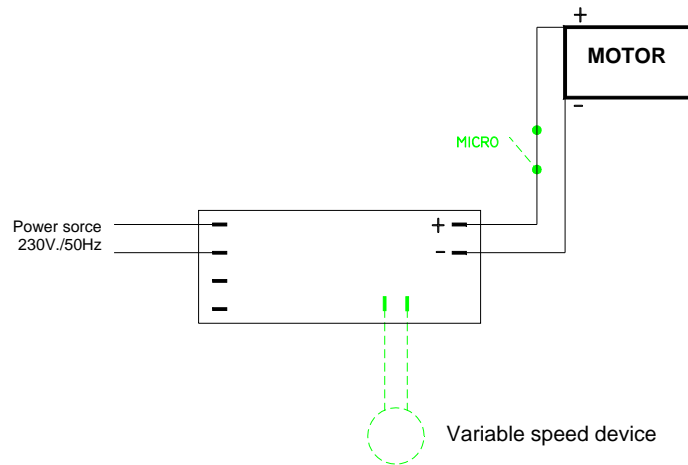

FIG. n°5 - Wiring diagram Mn

1.3 - APPLIANCE DESCRIPTION

1.3.1 - General Description

- We have designed and manufactured this fruit-squeezer for squeezing fruit guaranteeing:
- the maximum of safety when using, cleaning and servicing;
- the maximum of hygiene thanks to a meticulous selection of the materials that come in contact with the food product, and thanks to the elimination of any sharp and rough edges that come in contact with the product, cleaning is easy and thorough and components can be easily removed;
- robust and stable components and structure
- maximum reduced noise level ;
- easy to handle.

1.3.2 - Constructive Characteristics

The fruit-squeezer is made from aluminium, which ensure hygiene, acid and salt proofness and resistance to oxidation.

The juice container is made from stainless steel and the Sieve/reamer is made from ABS suitable for food products. The main structure is in steel.

1.3.3 - Appliance Components

FIG. n°1 - general view of the appliance

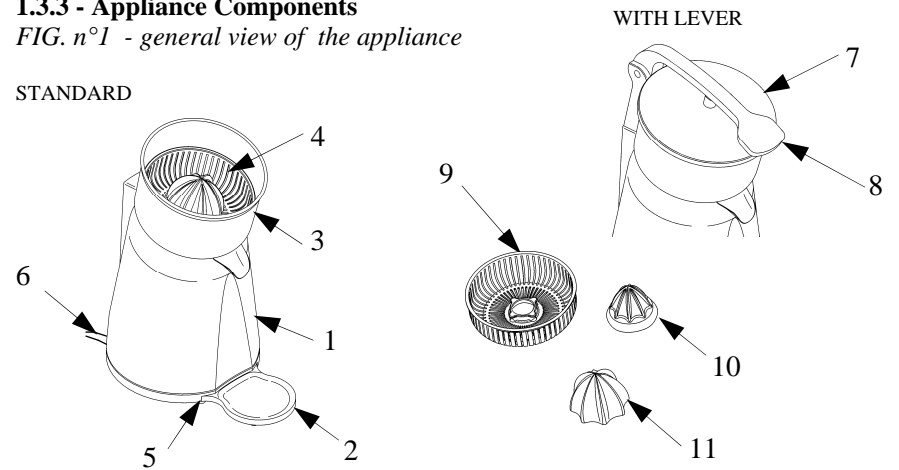

LEGEND:

- 1 - Main structure
- 2 - Base
- 3 - Juice container
- 4 - Sieve and reamers
- 5 - Foot supports

- 6 - Power supply cable
- 7 - Cover
- 8 - Lever
- 9 - Sieve
- 10 - Reamer small
- 11 - Reamer big

CHAP. 2 - TECHNICAL DATA

2.1 - MEASUREMENTS, WEIGHT, CHARACTERISTICS ...

FIG. n°2 - Overall dimensions

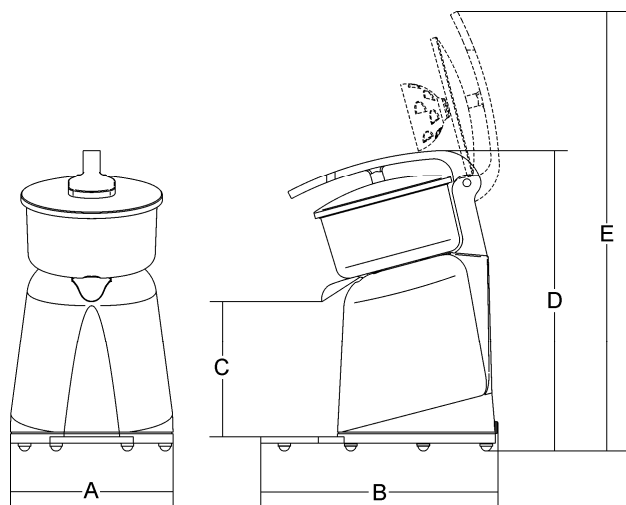

TAB. n°1 - MEASUREMENTS AND TECHNICAL CHARACTERISTICS

Model	u.m.	Standard	VV	Standard (with lever)	VV (with lever)
A x B x D	mm	210x300x355	210x300x355	210x300x385	210x300x385
E	mm	-	-	570	570
C	mm	173	173	173	173
Revolutions	g/l'	320	280÷750	320	280÷750
Motor	W	150	150	150	150
Power supply	Mn	230V/50Hz	230V/50Hz	230V/50Hz	230V/50Hz
Net weight	kg	4,5	4,5	5	5
Noise level	dB	≤80	≤80	≤80	≤80

CAUTION: the appliance is designed for the electrical specifications given on the plate applied to the rear of the appliance; before connecting to the electricity power supply refer to chapter 4.2 connecting to the electricity supply.

CHAP. 3 - CONSIGNING THE APPLIANCE

3.1 - TRANSPORTING THE APPLIANCE (see FIG. n°3)

The fruit-squeezer leaves our warehouse carefully packed; packaging consists in:

- a resistant cardboard box;
- the appliance;
- this manual;
- CE Certificate of Conformity.

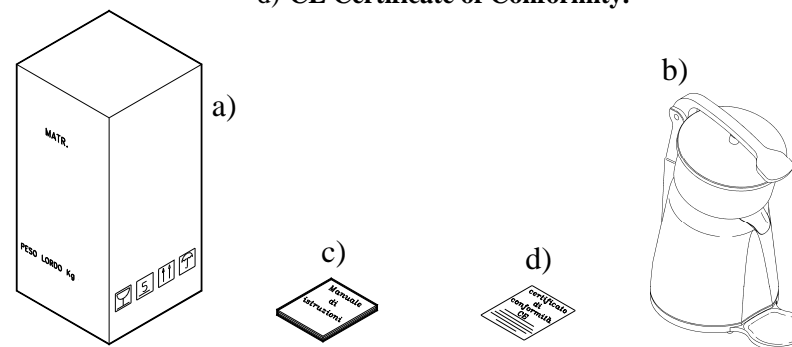

FIG. n°3 - Packaging

3.2 - CHECKING PACKAGING UPON CONSIGNMENT

When the goods are received proceed with opening the packaging if there are no signs of damage, and make sure that inside there are all the listed items (see Fig. n°3). If when the goods are delivered there are signs of damage to the packaging, such as dents or if they have been dropped, immediately inform the forwarding agent or courier, and within three days from the date indicated on the documents draw up a detailed list and report of all damage to the goods. **Do not turn the packed goods upside down!!** When transporting the package make sure its four main points are firmly secured (maintain the goods parallel to the ground).

3.3 - DISPOSING OF PACKAGING

The various items used for packaging (cardboard, plastic straps) are normal urban waste products and can be disposed of without difficulty.

If the appliance is destined to countries where there are specific standards regarding waste, dispose of packaging respecting the standards and laws in force.

CHAP. 4 - INSTALLING THE APPLIANCE

4.1 - APPLIANCE LOCATION

The work surface where the appliance will be located must be suitable for its size, please refer to the measurements given in Tab. 1. (depending on the model). The