



Model

EC12

Product Description

EC12 – Electrically Operated High-Volume Chipper

Product Code

5EC13 – 12 x 12mm, 5EC14 – 14 x 14mm

5EC17 – 14 x 17mm, 5EC21 – 17x 21mm



Standard Features

- Production capacity of up to 25kgs of chips per minute, with minimum waste
- Hopper load of 12kgs
- Interchangeable knife assembly offers a choice of four chip sizes; 12 x 12mm, 14 x 14mm, 14 x 17mm and 17 x 21mm
- If you require an additional cutting configuration, please order an additional blade assembly / complete knife block
- Rust proof stainless steel construction allows easy maintenance, cleaning and high standard of hygiene
- No tooling required to dismantle machine or change blades
- Fully interlocked and safeguard with no volt release to prevent automatic restart in the event of an interruption in power supply
- Optional stainless-steel stand available
- Powerful 0.25hp (0.18kw) belt drive motor
- CE Approved

Included as Standard

1 x EC12 – Electrically Operated High-Volume Chipper
 1 x Blade Assembly / Complete Knife Block (Size depending on selection)

Warranty

Covered by Metcalfe 1-year warranty and full after sales service

Optional Accessories

Part No.	Item
9EC12K02	Blade Assembly / Complete Knife Block (12 x 12mm)
9EC12K04	Blade Assembly / Complete Knife Block (14 x 14mm)
9EC12K01	Blade Assembly / Complete Knife Block (14 x 17mm)
9EC12K05	Blade Assembly / Complete Knife Block (17 x 21mm)
5EC12S	Stainless Steel Stand (lifts discharge height to 795mm)

Dimensions

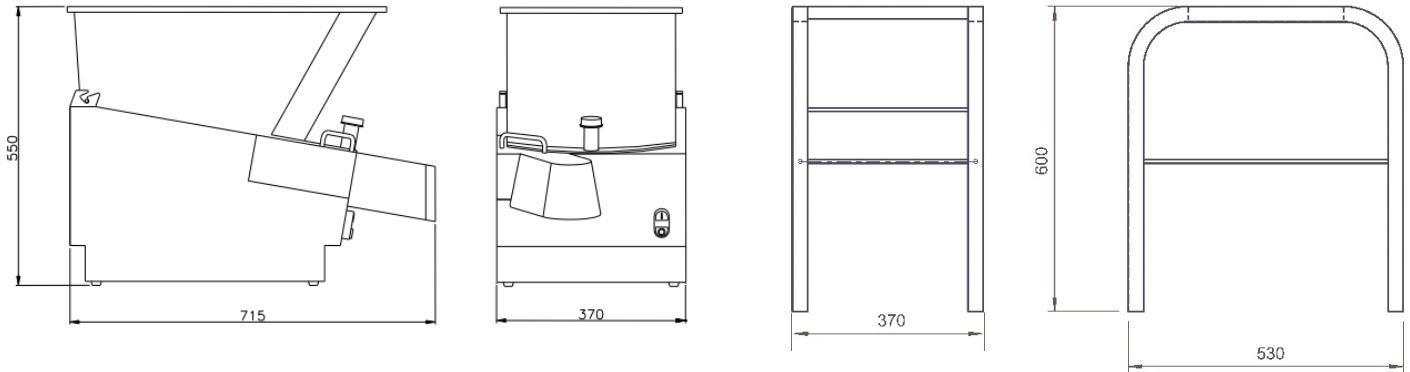

Specifications

Model	Product Code	Cutting Size (mm)	Output (kgs) per minute	Phase (Ø)	Motor (Volt)	Frequency (Hz)	AMP (A)	Power (kW) / (hp)
EC12	5EC13	12 x 12	25	1	230	50	10	0.18 / 0.25
EC12	5EC14	14 x 14	25	1	230	50	10	0.18 / 0.25
EC12	5EC17	14 x 17	25	1	230	50	10	0.18 / 0.25
EC12	5EC21	17 x 21	25	1	230	50	10	0.18 / 0.25

Dimensions | Shipping Information

Model	Overall Dimensions (D x W x H)	Net Weight (kg)	Packed Dimensions (D x W x H)	Packed Weight (kg)	Volume (m3)
EC12	715 x 370 x 550	46,0	670 x 420 x 670	56,0	0.188
Stand	530 x 370 x 600	6.0	518 x 310 x 590	7.5	0.095

We reserve the right to alter the specification and technical details for this item at anytime without prior notice.

©Metcalfe Catering Equipment Ltd

Metcalfe Catering Equipment Ltd
 Haygarth Park
 Blaenau Ffestiniog
 Gwynedd
 LL41 3PF
 Tel: 01766 830 456 | Fax: 01766 831 170
 E-mail: sales@metcalfecatering.com

View our current catalogue visit:
www.metcalfecatering.com/brochure

Or scan the QR code



EC12: 05/2019