

# Serie Mignon

## Manuale delle istruzioni per l'uso

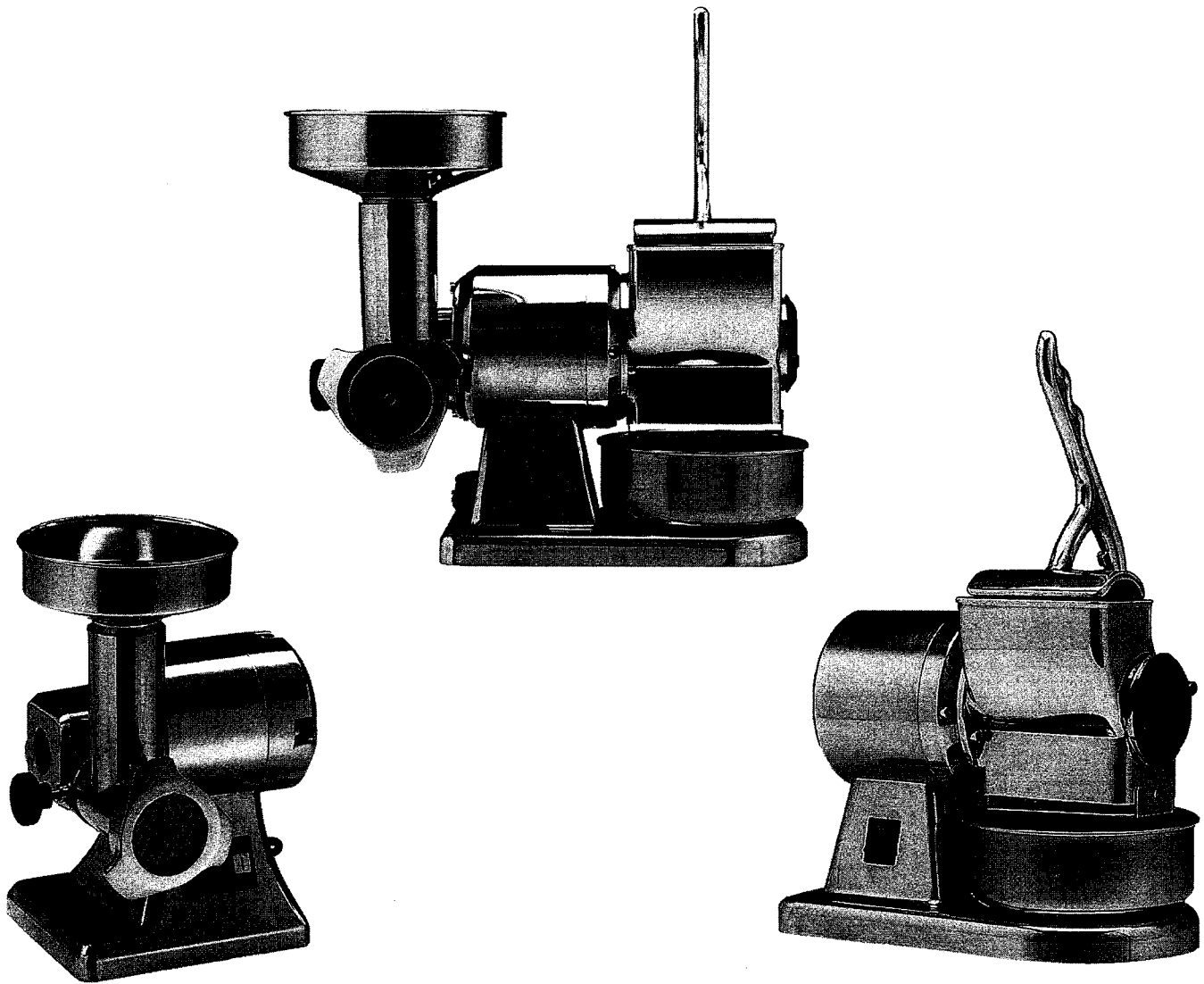

MODELLO	TS 8	TI 8	TG 8	TGI 8	GM
---------	------	------	------	-------	----

GB	SERIE MIGNON	OPERATING MANUAL
E	SERIE MIGNON	MANUAL DE INSTRUCCION
F	SERIE MIGNON	MANUEL D'UTILIZATION
D	SERIE MIGNON	BEDIENUNGSANLEITUNG
RUS	СЕРИЯ МИГЬОН	РУКОВОДСТВО ПО ИСПОЛЬЗОВАНИЮ

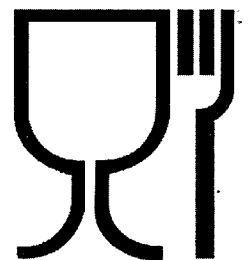

# CHAP. 1. CONTENT ORGANIZATION AND CONSULTATION MODALITY

## MANUAL PURPOSE

### MANUAL IMPORTANCE

The present instruction manual for the use is to be considered as **integral part of the machine**:

1. Must be kept for all the machine life.
2. Must be coupled with the machine in case of its ceasing.
3. Besides to show all useful notices for the operators, contains (collected in specific chapters) the electric diagrams that will be used for the possible maintenance interventions and reparation.

Besides the present manual has been written with the purpose to supply **indications and warnings** to know the supplied machine, to understand its principles and functioning limits. For possible doubts you can call the Authorized Assistance Center.

### RESPONSABILITY

- If the present manual endures damages or is lost, it is possible to request a copy to the Authorized Assistance Center.
- The present manual reflects the technical state during the machine manufacturing; the manufacturer reserves the right to update the production and of consequence other manual issues, without the obligation to update productions or previous manuals, if not in particular cases regarding the health and the people safety.
- Pay particularly attention to the residual risks content present on the machine and the prescriptions to which the operators must keep.
- The manufacturer is the responsible for the machine in its original configuration.
- The manufacturer isn't the responsible for damages caused from the improper use or not correct of the machine and documentation or for damages caused from the imperative standards violation, negligence, lack of experience, imprudence and the not respect of regulation standards on behalf of the employer, of the operator or the maintenance man and for every possible damage, caused from an irrational, improper and/or wrong use.
- The manufacturer isn't the responsible for the consequences caused from the not original spare parts use or of equal characteristics.
- The manufacturer is the responsible only for the information showed in the manual original version in Italian language.
- The prescriptions non-fulfillment contained in this manual will cause the guarantee immediate decay.

The factory responsables, that supervision to the working activities, in the field of the foreseen respective attributions and competence, must:

- Carry out the foreseen safety measures;
- Make informed the operators about the specific risks whom are exposed and bring to their knowledge the prevention essential standards;
- Prepare and require that the single operators observe the safety standards and use the protection means put at their disposal;
- Work an operator, contemporary, on this product.

# CHAP. 2. GENERAL INFORMATION AND CHARACTERISTICS

## GENERAL INFORMATION AND CHARACTERISTICS

**Meat mincer designed to be used with plate holes diameter smaller or equal to 8mm.**

The mincer – grater, here follow is called “machine”, è designed for:

1. With the grinding group placed from a side, to mince, reduce of size **fresh meat not frozen, through cutting tools** to obtain meat sauce, hamburgers, meatballs and sausages. The meat must be without bones, or other parts of different consistency from the meat.
2. With the grater group placed on the opposite side of the machine, to **grater tough cheese, bread and biscuits**.

In the grinding group, the machine is constituted from an electric motor inserted in a unique merger (basic machine body). In some versions the merger can be recovered from a bonnet (hulled machine body).

The meat to grind, is loaded manually in the load hopper, placed in the superior zone of the machine and always manually and with the pestle help is introduced in the grinding neck towards the Archimedean screw.

The hopper is blocked to the machine neck. The pestle is of plastic material suitable for the contact with food products.

**The grinding group is of Enterprise type it comes with 6mm plate holes diameter.**

The plate in turn is pressed against the cutter from the wheel inserted on the grinding group mouth.

The grinding group is dismantable; all direct contact materials with the food material are in conformance with the actual hygienic standards for food.

In the grinding group, the motor used for the grater rotation is the same used in the grinding group.

The product to grate is loaded manually inside the grater mouth placed in the machine superior zone, and always manually, acting the pressure with its handle, the product is driven against the grater roll.

The product load must happen in moderate quantity to avoid that lowering the pressure the machine doesn't start, due to the safety micro switch placed in the pressure block.

The grater roll, which can be milled, cannot be removed from the machine.

The machine is supplied with the identification plate on which the following data are showed:

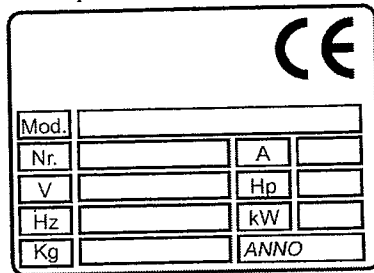

[fac simile]

### TECHNICAL AND MANUFACTURING DATA

TECHNICAL DATA	MODEL				
	TS 8	TI 8	TG 8	TGI 8	GM
Motor power (kW) / (Hp)	0.38/ 0,5	0.38/ 0,5	0,38/ 0,5	0.38/ 0,5	0.38/ 0,5
Grinding mouth internal size (mm)	60	60	60	60	---
Grater mouth internal size (mm)	---	---	110 x 65	110 x 65	110 x 65
Mincer timetable production (kg/h)	50	50	50	50	---
Grater timetable production (kg/h)	---	---	30	30	30
Mass (kg)	9	10	10	12	8
Maximum sizes: A x B x C (mm)	270 x 260 x 360	270 x 280 x 350	380 x 260 x 360	400 x 280 x 360	280 x 170 x 310
Continue acoustic power level considered equal to A	Minor of 70dBa				
Current nature - Frequency	Machine plate				
Full charge current	Machine plate				
Use nominal voltage	Machine plate				
Auxiliary circuits voltage	AC 24V - DC 24V				
Mass and neutral	TT e TN				
Protection degree	IP X3				
Use place	Inside				
Machine positioning	Working ground used in the food field of height included between 900/1100mm from the trampling level of adequate capacity, with a free circulation space of at least 800mm				
Environment air max. temperature	+40°C				
Requested minimum illumination	500 lux				
Product directive conformance	98/37/CE, 73/32/CEE and successive modifications and integration, Reg. 1935/2004				

GROUP	MODEL				
	TS 8	TI 8	TG 8	TGI 8	GM
Basic machine body	●		●		●
Hulled machine body (I)		●		●	
Grinding group	●	●	●	●	
Milled grater roll			●	●	●

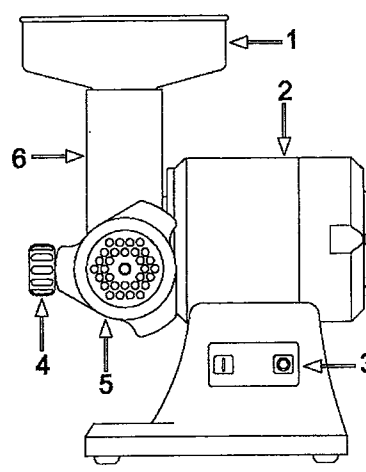
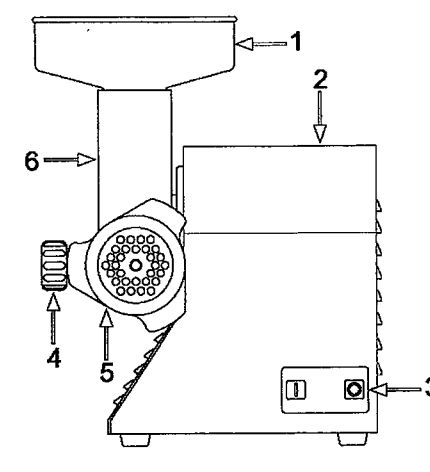
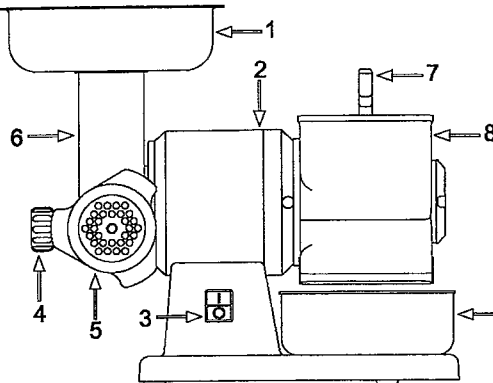
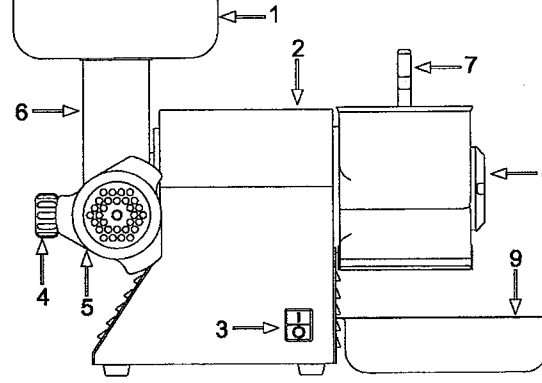
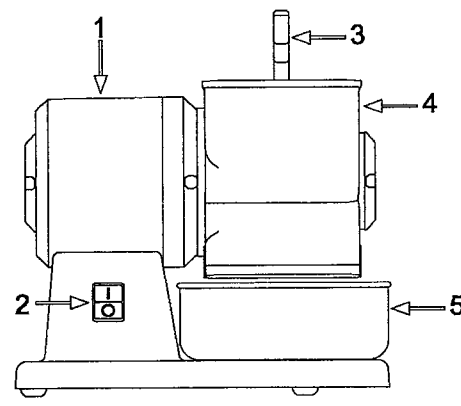
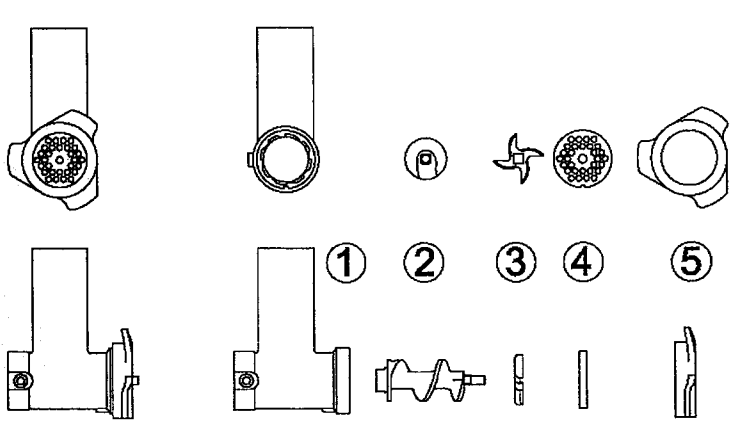
GROUP	EXAMPLE	
<ol style="list-style-type: none"> <li>1. Load hopper</li> <li>2. Machine body</li> <li>3. Control switch ON / OFF</li> <li>4. Mouth block knob</li> <li>5. Blockage wheel</li> <li>6. Machine neck</li> </ol>	 <p style="text-align: center;"><b>Mincer: basic machine body</b></p>	 <p style="text-align: center;"><b>Mincer: hulled machine body (I)</b></p>
<ol style="list-style-type: none"> <li>1. Load hopper</li> <li>2. Machine body</li> <li>3. Control switch ON / OFF</li> <li>4. Mouth block knob</li> <li>5. Blockage wheel</li> <li>6. Machine neck</li> <li>7. Pressure handle</li> <li>8. Grater mouth</li> <li>9. Collect container</li> </ol>	 <p style="text-align: center;"><b>Mincer/Grater: basic machine body</b></p>	 <p style="text-align: center;"><b>Mincer/grater: hulled machine body (I)</b></p>
<ol style="list-style-type: none"> <li>1. Machine body</li> <li>2. Control switch ON / OFF</li> <li>3. Pressure handle</li> <li>4. Grater mouth</li> <li>5. Collect container</li> </ol>	 <p style="text-align: center;"><b>Grater: basic machine body</b></p>	
<p><b>Grinding group</b></p> <ol style="list-style-type: none"> <li>1. Grinding mouth</li> <li>2. Archimedean screw</li> <li>3. Cutting knife</li> <li>4. Drilled plate</li> <li>5. Blockage wheel</li> </ol>		

## **NORMAL USE, IMPROPER USE, NOT CORRECT USE OR FORBIDDEN**

The machine described in the present instructions manual for the use is foreseen to be driven **from an only operator** skilled and prepared on residual risks, but with the competence, in safety matter, of maintenance employees.

ENGLISH

In its **NORMAL USE**, and reasonably foreseeable, the machine can be used only for:

1. **With the grinding group**, to mince, reduce of size **fresh meat not frozen, through cutting tools** to obtain stew, hamburgers, meatballs and sausages. The meat must be without bones or other parts of consistency different from the meat.
2. **With the grater group**, to **grate tough cheese, bread and biscuits**.

The machine must not be used **IN IMPROPER WAY**; in particular:

1. It must not be used for domestic uses,
2. It must not functioned with parameters different from those showed in the technical characteristics table,
3. For every use of the machine with modalities different from those showed in the present manual, the manufacturer declines every responsibility,
4. The user is responsible of the damages resulting from the lacked exercise conditions observance in accordance with the greed technical specifications and order confirmation,
5. **The grinding group must not functioned in vain; when the grater group is used, disassembly the grinding group,**
6. Not tamper or damage intentionally nor remove or hide the labels.

The machine must not be used **IN NOT CORRECT WAY** or **FORBIDDEN** so some damages or injuries could be caused for the operator; in particular:

1. It is forbidden **to move the machine** when it is connected to the electric feeding;
2. It is forbidden **to draw the electric feeding cable or the machine** to disconnect the feeding plug,
3. It is forbidden **to put weights** on the machine or on the electric feeding cable,
4. It is forbidden to **put the electric feeding cable** on sharp parts or with burn danger,
5. It is forbidden the machine use with the damaged and not integer **electric feeding cable or with the control devices;**
6. It is forbidden to **leave the machine off** with the electric feeding cable connected with the feeding plug,
7. It is forbidden to **leave the loaded machine unguarded;**
8. It is forbidden to **insert any type of object** inside the motor ventilation cap;
9. It is forbidden to **put the machine above different objects from the working ground** used in the food field of height included between 900 - 1100mm from **the trampling level,**
10. It is forbidden to **insert any kind of object** under the machine base or put clothes or other between the machine support pressure feet and the working ground,
11. It is forbidden **the use of inflammable substances, corrosive or harmful for the cleaning,**
12. It is forbidden to **plunge the machine** in water or in other liquids;
13. It is forbidden **the not authorized personnel use** and with clothes different from that showed for the use,
14. It is forbidden to **introduce in the grinding neck and in the grater mouth, products or objects having characteristics** different from those showed in the normal use, such as for example bones, frozen meat, not food products, or other objects as scarves, etc...,
15. It is forbidden to **introduce in the exit zone of the grated product, any object,** as for example knives blades, etc...,
16. It is forbidden to **remove the hopper during** the machine working or however when some food product has been left to work,
17. It is forbidden to **slacken the mouth block knob or the blockage wheel** both during the working and however **before of 5 sec** from the machine stop control,
18. It is forbidden the functioning **with the protection shelters and fixes not blocked correctly or removed;**
19. It is forbidden **the partial removal** of the protections and of the danger signals.
20. It is forbidden the functioning without that all the **precautions about the residual risks elimination** have been adopted on behalf of the user,
21. It is forbidden to **smoke or use free flame devices** and manipulate incandescent materials, unless some suitable safety measures aren't adopted,
22. It is forbidden to work or **regulate the control and blockage devices as knobs or similar** both during the machine functioning, both if you aren't authorized
23. **the use of plates with holes diameter bigger than 8mm is forbidden.**

**The user is however responsible** of the damages resulting from the lacked observance of the specified normal use conditions. For possible doubts you can enquire at the Authorized Assistance Center.

## CHAP. 3. SAFETY INSTRUCTIONS

### WARNINGS ON THE RESIDUAL RISKS

#### RESIDUAL RISK DUE TO THE FIXED PROTECTIONS REMOVAL, INTERVENTIONS ON BROKEN/WORN PARTS

For any occasion the operator must not try to open or remove a fixed protection or tamper a safety device.

In the phase of **equipment, maintenance and cleaning**, and **during all further manual operations** that happens introducing the hands or other body parts in the machine dangerous areas, a residual risk remains due above all to:

1. **Knocks with machine manufacturing parts,**
2. **Grazing and/or abrasion with machine rough parts,**
3. **Sharp pain with the sharpened parts,**
4. **Cut with tools sharpened parts.**

Besides, the operator and the maintenance man **must be skilled for the intervention connected to the manual operations with open protections**, must be trained on the joined consequent risks and must be authorized from a responsible person.

### PROTECTION DEVICES ON THE MACHINE

The machine protections and safety devices must not be removed.

If they must be removed for extraordinary maintenance requirements **some measures will have to be immediately adopted ready to put in evidence and to reduce at the possible minimum limit the danger.**

**The putting back in its place** of the protection or of the safety device must happen as soon as the reasons, that have made necessary their temporary removal, are stopped.

**The machine transmission parts** are completely isolated by means of fixed protections which don't allow the access for none kinematical chain.

For all **safety functions** including the control and check systems parts joined to the safety, some well-tested components and safety principles have been used.

#### **Grinding group:**

1. Taking into account of the machine use modality and its use destination, the moving elements aren't isolated from fixed protections, moving protections or other safety devices.
2. The grinding group parts result placed at some distances from the access points such for which some dangerous points aren't reachable.

#### **Grater group:**

1. Taking into account of the machine use modality and its use destination, the moving elements aren't isolated from fixed protections, moving protections or other safety devices.
2. On handle and pressure group a micro switch is placed, which stops the grater roll rotation when it is possible to access through the grater mouth;
3. In the inferior zone of the grater group in correspondence of the grated product exile a grating form fixed protection is present, which prevent the fingers access towards the grater roll.

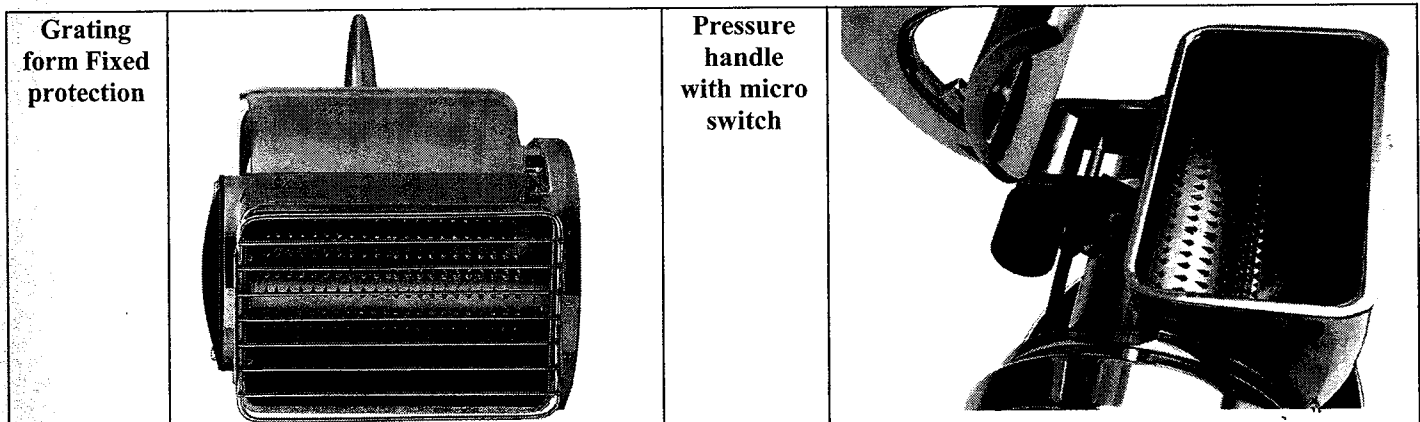

## CHAP. 4. TRANSPORTATION, PUT ON SERVICE AND USE

The machine management is allowed only to the authorized personnel and opportunely educated and endowed of a sufficient technical experience.

**Before to switch on the machine** perform the following operations:

- Read with attention the technical documentation,
- Know what protections and emergency devices are available on the machine, their location and functioning.

The not authorized use of commercial parts and accessories making part of the protections and safety devices can cause some malfunctions and the ranger situation beginning for the operators. **The operator must besides** have received an adequate training.

### PACKING REMOVAL – OPENING MODALITY

The machines are packed so that the infiltration / entering of liquids, organic matters or beings alive is avoided: this is performed from a **covering in polyethylene around the machine**, and inserted in a **cardboard box** of adequate size. The empty spaces inside the box are occupied from the **filling material**.

Don't waste the packing in the environment, but restore it for possible transportation or address it to the recycling agencies. The evaluation and the management with the aim of the products biological compatibility used in the packing are of the user competence and responsibility.

It is an employer obligation **to be acquainted of the actual laws in own country and work so that to observe these legislations**.

**It is forbidden and besides liable to fines**, leave the machine and the electric equipment in the environment.

### PREPARATION PRELIMINARY OPERATIONS

#### ELECTRIC FEEDING

The electric feeding connection must be in conformance with the **country legislation in which is used**.

The electric feeding must be always of the type and have an intensity corresponding to the specifications indicated in the machine number plate.

### GRINDING GROUP ASSEMBLY / DISASSEMBLY

The assembly / disassembly operations of any machine part are performed with the stop machine and with the plug disconnected from the socket, or with the sectioning device in OFF.

The **grinding group** assembly on the machine takes place in two phases (in exemplifying way it is showed the grater mincer with basic machine).

<p>The phase n. 1 for the <b>grinding group</b> is performed on a working ground following the under reported order:</p> <ol style="list-style-type: none"> <li>1. Insert in the pipe union (1) in the order: Archimedean screw (2), cutting knife oriented as in figure and inserted in the dragging pivot (3), drilled plate (4) inserted in the pipe union place (1);</li> <li>2. Screw down and tighten the blockage wheel (5).</li> </ol>	
<p>The phase 2 is performed on the machine:</p> <ol style="list-style-type: none"> <li>1. Insert up to the blow the complete grinding group (B) on the machine (A);</li> <li>2. Tighten the mouth stop knob (C) up to when the grinding group (B) is blocked on the machine (A);</li> <li>3. Insert the hopper (D) in the machine neck</li> <li>4. In these conditions the machine is ready to work.</li> </ol>	

**The disassembly activities of the grinding group** from the machine are performed following in the backwards way the assembly phases previously described, starting from the phase n. 2 passing to the phase n. 1.

For a plate and knife better improvement and duration it is advised **to keep them always coupled**.

## FUNCTIONING DESCRIPTION

The control devices are designed and manufactured so as much sure and reliable and resistant to the service normal stresses, to the foreseeable strains and to the external agents. Besides they are clearly visible, locatable and marked from a suitable marking. Here follow the main **control devices** are showed:

TYPE / COLOR	REFERENCE / DESCRIPTION
button / black	"0" / button for the machine stop control
Button / white	"I" / button for the machine start control

### STARTING

The machine starting is possible only **with a voluntary action** on the **control device foreseen for this aim**: white button "I" for the machine starting control.

### STOP

For the stop control push the black button "0". In case of **momentary or extended stop**, before to get in function the machine, all food products must be removed within the machine: follow the indications relative to the grinding group disassembly.

### FUNCTIONING SAFETY

If the machine is **under stress**, or is submitted to too long functioning times or submitted at overloaded, the same stops immediately for the thermal protection functioning. In this case **wait that it is completely cooled** before proceeding to the starting function.

### VOLTAGE LACKING

In case of electric feeding breaking or if the machine is disconnected from the electric net, this last one will be able to be restarted only following the starting function, **after the electric feeding back or the reconnection to the electric net**.

### PRESSURE OPENING

Lifting for the handle the pressure of the grater group, the machine stops immediately for the safety micro switch functioning. The machine can be restarted only lowering the pressure up to the height that doesn't allow the fingers introduction towards the grater roll and following successively the starting function.

### CONTROLS AND VERIFICATIONS BEFORE STARTING

VERIFICATION / CONTROL	MODALITY AND CHECKS
<u>Check that:</u> > Extraneous objects <b>aren't on the machine, inside the hopper, inside the machine neck, inside the grater mouth and in correspondence of the exile zone of the grated product</b>	Sight control of the indicated parts, to check of objects or extraneous bodies lacking as for example different tools, clothes, etc... and that there isn't however the food product. In case of presence, provide with their removal.
<u>Check the cleaning:</u> > <b>Of the machine neck internal parts and of the grinding group</b> > <b>Of the pusher</b> > <b>of the grater mouth, of the pressure and the grater roll</b> > <b>of the machine external surface</b>	All indicated parts surfaces, before the machine use must be checked visually to verify their cleaning. For the sight check of the grinding group internal parts, provide with its disassembly. In case of molds presence or other type of dirtiness, provide with the cleaning procedure in accordance with the chapter 5 indications
<u>Check the integrity:</u> > <b>of the fixed protections,</b> > <b>of the loading hopper,</b> > <b>of the machine neck,</b> > <b>of the grater mouth, the pressure and the grater roll</b> > <b>of the machine body</b>	All fixed protections, etc..., must perform the function for which have been foreseen. Indicated parts sight check to verify their integrity in their surface external part. The parts must be however changed at the first erosion signals or breaking.
<u>Check the functionality:</u> > <b>of the control system parts / safety control;</b> > <b>Of the control devices.</b>	All devices must perform the function for which have been foreseen. Control directly the devices so that these ones determine the waiting function. The actuators and all parts must be however changed to the first erosion signals or breaking.
<u>Check the absence:</u> > <b>Of strange noises after the starting</b>	During the functionality checking of the control devices, if there are strange noises, due for example to a seizing or mechanical breaks stop immediately the machine and activate the maintenance service.
<u>Check the absence:</u> > <b>Of oil trails both on the machine support ground both in the Archimedean screw</b>	Both during the working, both at the end of every work, both in the assembly moment of the grinding group; check the oil trails absence in the indicated parts. If there are some fluid drops stop immediately the machine and activate the maintenance service.



For any intervention type or for the parts change that are damaged, **activate the maintenance service**. The possible change must happen with manufacturer original products or at least of quality, safety and equivalent characteristics. For analysis contact the Authorized Assistance Center.

ENGLISH

### **PUT IN FUNCTION**

The machine operator can put in function the machine following in order the under reported indications:

1. Controls positive result for the preparation preliminary operations,
2. Controls positive result for the electric feeding,
3. Plug connection in opportune current socket,
4. For the functioning of the **GRINDING GROUP**:
  - a. Checks positive result for the grinding group assembly,
  - b. Checks positive result for the Archimedean screw correct rotation,
  - c. Checks positive result / verifications before starting,
  - d. Finalized checks positive result and verify the all safety conditions respect,
  - e. Lower in its lowest position the pressure handle of the grater group,
  - f. Place a gathering basin in the machine anterior zone in correspondence of the ground meat exit zone,
  - g. Put in the machine left side and start the machine acting the control device of start "I",
  - h. Introduce manually the food product within the machine neck and drive it towards the Archimedean screw using the pestle in equipment,
  - i. At the end of the food product introduction, or when from the drilled plate doesn't come out more the product, stop the machine acting the control device of stop "0".
5. For the functioning of the **GRATER GROUP**:
  - a. Grinding group disassembly,
  - b. Checks positive result for the grater roll correct rotation,
  - c. Checks positive result / verifications before the starting,
  - d. Finalized checks positive result and verify the all safety conditions respect,
  - e. Place a gathering basin in the machine anterior zone in correspondence of the grated product exit zone,
  - f. Put in the machine left side and start the machine acting the control device of start "I",
  - g. Introduce manually the food product within the grater mouth and drive it towards the grater roll lowering the pressure roll,
  - h. At the end of the food product introduction, or when in the basins the product is not more left, stop the machine acting the control device of stop "0".

**It is recommended to make not work the machine in vain, without the food product.**

**It is recommended to make not work the grater group, with the assembled grinding group.**

### **SWITCHING OFF**

In succession, the switching off must follow what here under indicated:

1. Before the switching off wait the food product exile conclusion from the drilled plate or in the grater roll inferior zone,
2. Stop the machine acting the control device of stop "0",
3. Disconnect the machine plug from the feeding socket,
4. Perform the cleaning interventions.

### **UNBLOCK IN CASE OF OBSTACLE**

During the working, or during the Archimedean screw rotation or of the grater group, due to:

1. The introduction of food products with not homogeneous parts, as for example bones, or other,
2. The introduction of products excessively hard and dry, the machine could block, the machine could block.

The same situation can determine after an electric feeding break, or when the machine is stopped with inside the food product.

To be able to resume normally the working:

1. If the block is happened in the grinding group, this must be disassembled: the disassembly must not happen slacking the blockage wheel, but slacking the grinding mouth block knob,
2. If the block is happened in the grater roll, the blocked food product must be removed manually.

## CHAP. 5. DAMGES RESEARCH AND CLEANING

### BREAKS OR DAMAGES RESEARCH AND MOVING ELEMENTS UNBLOCKING

Here follow are indicate the interventions for the **breaks or damages research and moving elements unblocking** which can be performed from maintenance men.

TYPE	POTENTIAL CAUSE/S	MODALITY AND COMPARISONS
Net voltage lacking	General Black out	Contact the electric energy distributor
	Fuses or magneto thermals intervention place upstream of the machine feeding line	After having eliminated the causes that have determined the protection device intervention, restore it. In case of problem persistency contact an electrician technician.
Functioning intervention	Protection device intervention inside the machine	Contact an electrician technician: after having eliminated the causes that have determined the protection device intervention, restore it. <b><u>In case of fuses intervention</u></b> , change them with types of the same model, calibration and intervention curve.
	Grater group handle lifting	Lifting the grater group pressure handle, the machine stops immediately for the entry in function of the safety micro switch. Lower the pressure up to the height that doesn't allow the fingers introduction towards the grater roll and start the machine.
	Cause/s not identifiable	Contact directly the <u>Authorized Assistance Center</u>
The machine doesn't function: the Archimedean screw or the grater roll don't rotate	Feeding voltage lacking.	Check and restore the electric energy.
	Sectioning devices set on "OFF".	Turn the sectioning devices in the position "ON"
	Intervened fuses or not functioning magneto thermals.	Change the intervened fuses, check the magneto thermal switches state.
	Lacked running button functioning	Check the START button efficiency and eventually contact directly the <u>Authorized Assistance Center</u> .
	Thermal intervention due to the overheating	Wait the complete cooling before the machine restarting
	Damaged micro switch	contact directly the <u>Authorized Assistance Center</u>

### CLEANING

**It is forbidden to clean by hand the organs and the elements in motion.**

All cleaning interventions must be started only and exclusively, **after having unloaded the machine with the food product in working and having insulated from the electric feeding source and from external energy.**

The machine, the electric equipment and the machine board components **must not be ever washed utilizing water, and not in any kind of jets form and quantity; so, without "bucket" nor "rubber" nor "towel"**. Don't put ever directly the machine in the sink or under the tap.

**The machine hygiene level classification and the associated equipment, for the foreseen use, is 2 (two):** machine that, after an hygiene risk evaluation, is in conformance with applicable international standards requirements, but requests a programmed disassembly for the cleaning.

### MODALITY

All the surface and the machine parts destined to come in contact with the food product or with **the food zones** (hopper internal surface, machine neck and the grinding group, the pestle, the pressure, the grater mouth and the grater roll) and the **jets zones** (machine external surface) must be cleaned and disinfected with the under reported modalities. For the grinding group disassembly activities see the previous descriptions.

- **Scrape the surfaces from the possible food product residuals** (for example with plastic scrapers);
- **Clean all the food zone surfaces and jets zone with a morbid dampened clothes (not draining) with detergent diluted in hot water** (also common soap for dishes is good). Don't soak them. With a towel clean inside the grinding mouth. Use specific products for steel, which must be liquids (not in cream or pastries however abrasive) and above all must not contain chlorine. Against the fat substances the denatured alcohol.
- **Rinse with cleaned hot water and successively dry all food zone surfaces and jets zone** with soft clothes that don't lose coats.
- The parts in steel stainless of the grinding group **can be washed also in dishwasher.**
- **The grinding group reassembly** must happen only after a working requirement, leave the pieces wrapped in a dry soft clothes that don't lose coats

### PERIODS OF LONG INACTIVITY

- During the machine long inactivity periods provide to pass vigorously on all steel surfaces (especially if stainless) a clothes soaked of Vaseline oil so that to spread a protective veil.

ENGLISH

### NOT TO MAKE THINGS BEFORE OR DURING THE CLEANING:

- Enter towards the moving elements without to be previously checked of their stop;
- Enter towards the moving elements without have stopped it in safety stop (blockage in zero position of the electric feeding sectioning devices)

### PRODUCTS NOT TO USE:

- Compressed air with jets towards the zones with flour warehouses and in general towards the machine;
- Vapor equipment;
- Detergent that contains **CLORO** (also if diluted) or its compounds as: the bleach, the muriatic acid, products to clear the drain, products for the marble cleaning, in general decalcifying, etc ... can attack the steel composition, staining and oxidizing it unavoidable. The only above described products fumes can oxidize and in any case corrode the steel;
- Steel wool, brushes or abrasive discs produced with other metals or alloys (ex. Common steel, aluminum, brass, etc...) or tools that have previously cleaned other metals or alloys, that except to scratch the surface.
- Detergents in abrasive dust;
- Fuel, solvents or inflammable and/or corrosive fluids;
- Substances used to clean the silver.

## CHAP. 6. SELLING

Actuation of the directives 2002/95/CE, 2002/96/CE and 2003/108/CE, about the dangerous substances use reduction in the electric and electronic equipment, as well as the refuse selling



The barred garbage symbol included on the machine shows the needs that the machinery at the end of its useful life is sold in appropriate centers

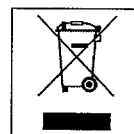

The present machine rubbish collection at the end of its life is organized and managed from the producer. The user that will be able to get rid of the present machine will have so to contact the producer and follow the new adopted system to allow the equipment rubbish collection reached at the life end.

The adequate rubbish collection for the equipment successive starting dismissed to the recycling, to the treatment and to the environmentally compatible selling contributes to prevent possible negative effects on the environment and on the health and favors the reuse and/or material recycling of the equipment.

In the machine dangerous substances are not present.



The product unauthorized selling on behalf of the holder behaves the administrative sanctions application foreseen from the actual standard.

## CHAP. 7. MANUFACTURING MATERIALS

In accordance with the functioning and production requirements, the machine can be constituted with different typology of manufacturing materials.

GROUP	MATERIALS TYPOLOGY				
	Stainless Steel 18/8	Stainless steel AISI 304	Stainless steel AISI 440	Aluminum for foods	Treated steel for foods
Machine body and hopper	●			●	
Knives and drilled plate			●		
Grinding group		●		●	
Milled grater roll		●			●
Pressure, handle, grater mouth				●	