

## Modular Super-Flake Ice Machine up to 2500 kg

Other models in this range:  
MF 46 - MF 47 - MF 56  
MF 58 Split - MF 59 Split - MF 66  
MF 68 Split - MF 69 Split  
MF 88 SPLIT



### Features

- Modular Superflake ice machine, production up to 2500 kg in 24 hours
- Semi-hermetic compressor
- Choice of air, water or remote air-cooled condensers
- Stainless steel auger and freezing cylinder (evaporator)
- Equipped with an electromechanical control panel
- Ice breaker made in specially strengthened alloy, allowing for greater extrusion pressure to deliver a dryer quality of ice (85% dry)
- Long-lasting stainless steel ball-bearings
- Current protection on gear motor and safety coupling between gear box and auger
- Low-water pressure switch
- Ice level thermostat for machine shut down
- Stainless steel side panels in scotch-brite finish, rounded corners for enhanced ease of cleaning and aesthetics
- Side panels are removable on all four sides to ease maintenance and after-sales service operations
- Top cover in PS
- Ice chute with extension
- Reduced height to ease installation
- CFC Free R-404A Refrigerant

### Optional Features (special order):

- Anti-scale, anti-algae water filtration system
- KICMAREXT0001 ice chute extension 90cm
- KICMARDOUBL02 double ice chute 65cm
- Infrared ice sensor
- KITTIMERSET01 weekly timer



PS plastic cover



Standard Ice Chute included

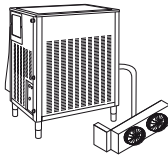

MF 86 ASR Remote Condenser



KICMAREXT Extension



MF 86+UBH2250  
(sold separately)

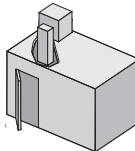

MF 86+B3200  
(sold separately)



MF 86+B4600  
(sold separately)



MF 86+SIS1350  
(sold separately)



MF 86+ITS2250  
(sold separately)



MF 86+ITS2250/ITS3250  
(sold separately)

### MF 86 Technologies



	+C° -C°	24h		21°C: 15°C		W D H [WxDxH mm] 1080x780x1255	
		[kg]	[lb]	[kg]	[lb]		
MF 86 AS		2500	5512	2250	4960	[WxDxH inches] 42 1/2 x 30 11/16 x 49 6/16	
MF 86 WS		2500	5512	2250	4960		
MF 86 ASR	Remote Air	2400	5291	2250	4960		
						 [V/Hz/ph] 400/50/3N Version AS aircooled also available in 230/60/3	 R 404A

This product qualifies for the following listings:



Residual umidity content 15%

Super-flake ice, extruded around 0° Celsius, retains only 15-18% of residual umidity, making it relatively dry and compact.

**2** Years Warranty

Subject to certain limitations and exclusions

Certified ISO 9001

[www.scotsman-ice.it](http://www.scotsman-ice.it)  
[www.scotsman-ice.com](http://www.scotsman-ice.com)

Models and specifications are subject to change without notice.

Other models in this range:  
 MF 46 - MF 47 - MF 56  
 MF 58 Split - MF 59 Split - MF 66  
 MF 68 Split - MF 69 Split  
 MF 88 SPLIT

## Modular Super-Flake Ice Machine up to 2500 kg

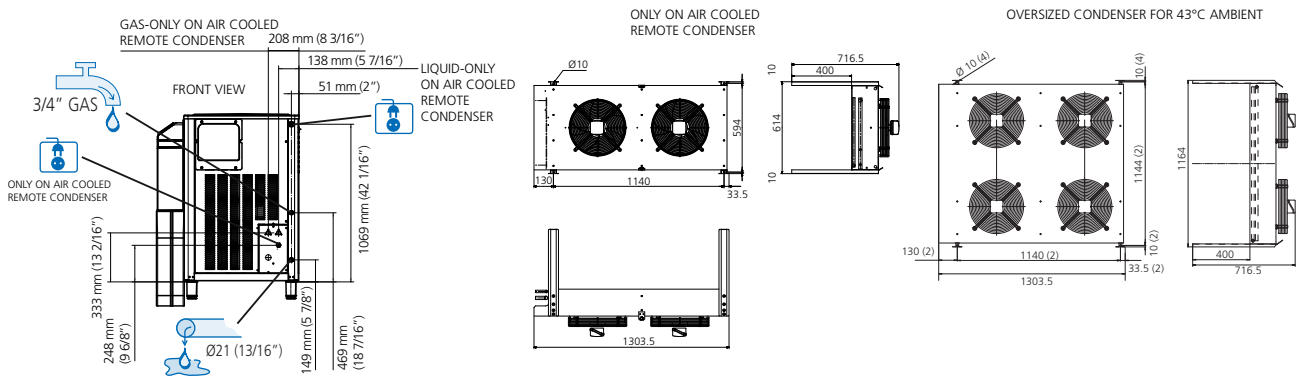
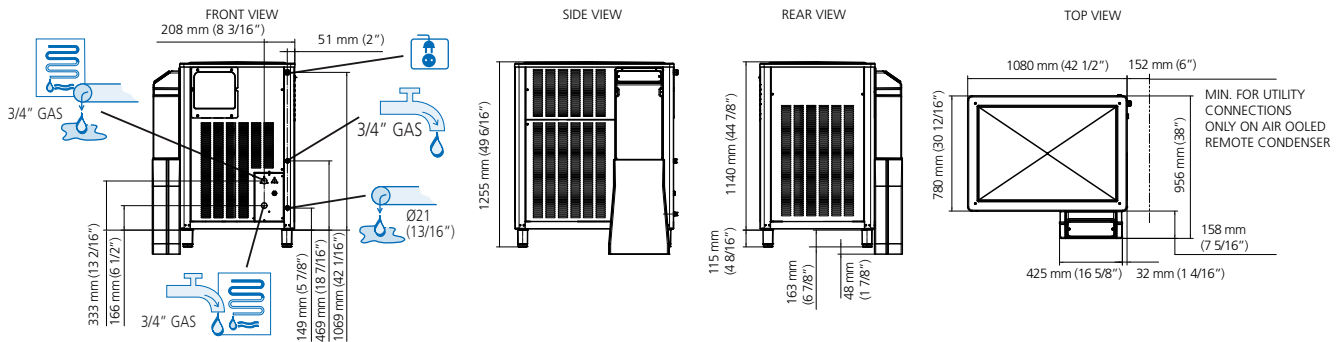

### MF 86 AIR COOLED

°C / °F	50° / 10°	60° / 15°	70° / 21°	90° / 32°
10°	2500	2330	2160	1820
50°	5512	5137	4762	4012
21°	2400	2250	2100	1800
70°	5291	4960	4630	3968
32°	2050	1950	1850	1650
90°	4519	4299	4078	3638
38°	1780	1710	1640	1500
100	3924	3770	3616	3307

### MF 86 WATER COOLED

°C / °F	50° / 10°	60° / 15°	70° / 21°	90° / 32°
10°	2500	2250	2050	1580
50°	5512	4960	4519	3483

Minimum 10°C (50°F)	Maximum 43°C (110°F)
5°C (41°F)	38°C (100°F)
-10%	+10%
1 bar 14 psi	5 bar 70 psi

						32°C / 90°F	21°C / 70°F							
	Icon	[Btu/h]	[W]	[Ømm²]	[W]	FUSE	100 kg	[kWh - 100 kg]	[l/h]	[gal/h]	[kg]	[lb]	[kg]	[lb]
MF 86 AS	Air Cooled	34120	10000	5 x 2,5	6250	25 A	7,4	7,4	79	21	390	859	411	904
MF 86 WS	Water Cooled	34120	10000	5 x 2,5	6250	25 A	7,4	7,4	1750	462	371	816	392	862
MF 86 ASR	Remote Air	34120	10000	5 x 2,5	6250	25 A	7,4	7,4	79	21	350	770	371	816