



## Storage Cabinets with Door



### Key Features

- Supplied upon adjustable stainless steel feet or castors
- Storage cabinet supplied with door
- 2mm thick 304 grade stainless steel hob
- Laser cut hob allows edge to edge joining of units
- Stainless steel external panels with Scotch Brite finish
- Dynamic Link System Compatible



Integrated linking system allows quick and easy installation to create a continuous cookline.

UK Patent No. 2540131

### Model Diagram (mm)

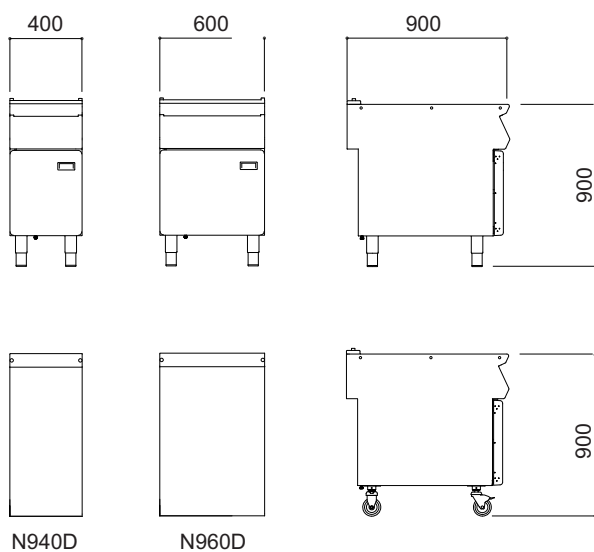

### Accessories

- Front rail
- Side cover plate
- Kick plate
- Castors

### Short Form Specification

Unit to be storage cabinet with door. Supplied upon adjustable feet or castors. Exterior panels are Scotch Brite finish stainless steel. Right-angled edges allow flush joining of units.

### Weights

|                        | N940D               | N960D               |
|------------------------|---------------------|---------------------|
| Weight (kg)            | 40                  | 53                  |
| Packed weight (kg)     | 48                  | 61                  |
| Packed dimensions (mm) | 450 x 970<br>x 1090 | 650 x 970<br>x 1090 |