



DISHWASHER AX-100BC 230/50/1

Rack size 500x500mm and door clearance 430 mm.

1303313



WARE WASHING
PASS-THROUGH DISHWASHERS

SALES DESCRIPTION

Sani-Control: guaranteed disinfection. Constant high temperature rinse system for optimal disinfection. Exclusive Hydroblade™ washing arms: maximum effectiveness. 3-stage filtering system.

Sani-Control guarantee

- ✓ GUARANTEED DISINFECTION in compliance with standard DIN 10534.
- ✓ THERMAL LOCK function: Ensures that rinsing will be carried out at the ideal temperature to disinfect the dishes.
- ✓ CONSTANT HIGH TEMPERATURE RINSE system for optimal disinfection.
- ✓ The PRESSURE PUMP guarantees effective high-pressure rinsing
- ✓ WRAS certified.

New recessed bodywork

- ✓ Ergonomic design with rounded corners to prevent the accumulation of dirt and facilitate cleaning.
- ✓ Compact tank volume (50% water saving compared to the previous range).

Hydroblade™ washing arms

- ✓ Redesigned nozzles for greater washing performance.
- ✓ The “monoblock” design delivers durability and resistance to impacts.
- ✓ 30% savings in water consumption during rinsing compared to the previous range.

3-stage filter system: surface, tank and extraction

- ✓ Keeps the washing water in optimal conditions to maintain constant washing performance.

Designed to last

- ✓ “Flow” opening mechanism: allows the hood to be raised with less effort

- ✓ High load capacity 43 cm: suitable for GN 1/1 and Euronorm
- ✓ Stainless steel surface filters for greater stability and resistance during intensive use

Warewashing, made simple

- ✓ TEMPERATURE DISPLAY
- ✓ Control panel with IP65 humidity protection.

You will never WASH ALONE

- ✓ Tech-Services: our team of technicians will help you so that your machine is always ready for use.
- ✓ Design Services: tell us what your needs are and we will advise you.
- ✓ 60 years of experience and know-how at your disposal.

INCLUDES

- ✓ Detergent Dispenser. val in process 09/2021)
- ✓ Drainage pump with level sensor. Proactive tank water renewal.
- ✓ Type-A air break (WRAS approved)
- ✓ Rinse aid pump.
- ✓ 1 glasses basket.
- ✓ 1 mixed basket (plates).
- ✓ 1 cutlery basket.

OPTIONAL

- Automatic resin regeneration water softener with salt detector.

ACCESSORIES

- Tables for dishwashers P/X/S (pass-through model)
- Manual water softeners
- Automatic water softeners
- 500 x 500 mm. baskets
- Inserts & supplements
- Central sorting tables
- Double connection central
- sorting table
- Prewashing tables for pass-through and rack conveyor dishwashers
- Connecting tables for Pass-Through dishwashers and rack conveyors
- Reverse Osmosis device OS-140P

SPECIFICATIONS

Basket dimensions: 500 mm x 500 mm
Maximum glass height: 430 mm

Cycles: 3
Cycle duration: 120 / 180 / 210 “
Production baskets/hour: 30 / 24 / 17

- ✓ Boiler capacity: 12 l
- ✓ Wash tank capacity: 25 l
- ✓ Water consumption/cycle: 2.8 l

Loading

- ✓ Pump: 750 W / 1.0 Hp
- ✓ Tank: 2500 W
- ✓ Boiler: 6000 W
- ✓ Total loading: 6750 W

Electrical supply: 230 V / 50 Hz / 1 ~ (30 A)

External dimensions (WxDxH)

- ✓ Width: 648 mm (: -- mm)
- ✓ Depth: 756 mm (: -- mm)
- ✓ Height: 2000 mm / 1508 mm

Wash temperature: -- °C
Rinse temperature: 87 °C





DISHWASHER AX-100BC 230/50/1

Rack size 500x500mm and door clearance 430 mm.



1303313

Net weight: 112 Kg
Noise level (1m.): -- dB(A)

760 x 860 x 1960 mm
Gross weight: 123 Kg

Crated dimensions

WARE WASHING
PASS-THROUGH DISHWASHERS

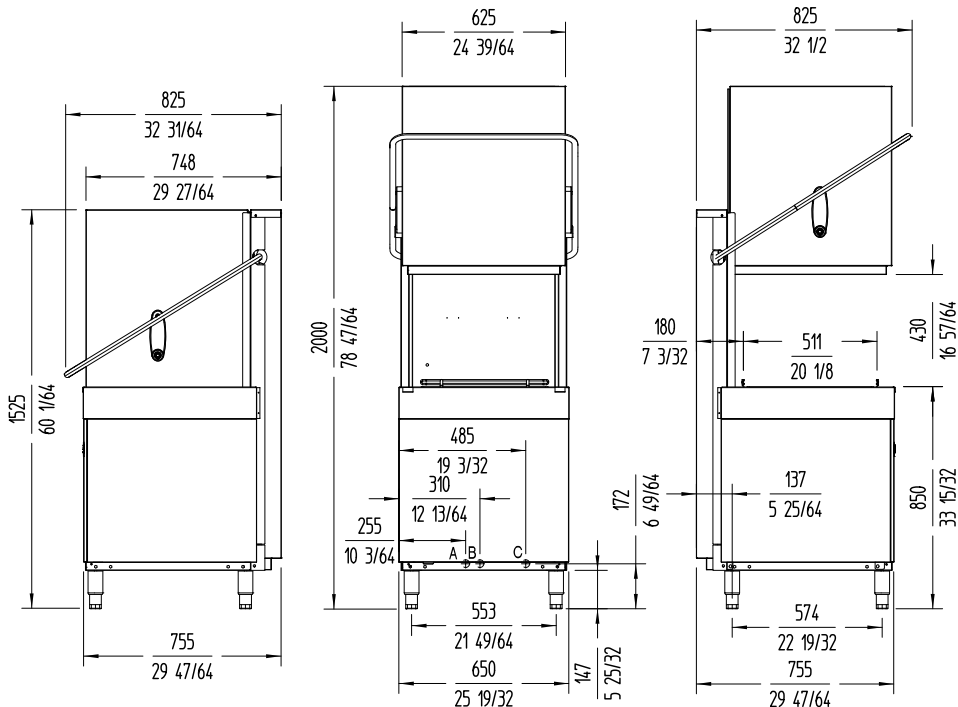

A: Entrada de agua 3/4" GAS.
B: Tubo de desagüe ø30 mm.
C: Cable conexión.



www.sammic.co.uk
Food Service Equipment Manufacturer
Unit 2, Trevanth Road
Troon Industrial Park
LE4 9LS - Leicester
uksales@sammic.com
Tel.: +44 0116 246 1900



Project	Date
Item	Qty
Approved	

product sheet
updated 12/04/2022