

Model:
PB50A

Prodis PB50A Bright Cube Under Counter Ice Maker
46 kg/24h Production | 15 kg Storage



General Information:

The Prodis PB Series is a range of precision ice-making tools engineered for the modern mixologist and premium hospitality environments. Each unit is designed to produce the signature “Bright Cube,” characterized by its exceptional clarity and high density. This is achieved through a sophisticated horizontal spray manifold system that freezes water in thin layers, eliminating air bubbles and impurities to create ice that is virtually invisible when submerged in a drink.

The functional density of the Bright Cube ensures a reduced surface area-to-mass ratio, allowing the ice to melt significantly slower than standard cubes. This preserves the integrity and flavor profile of premium spirits and complex cocktails by preventing over-dilution.

Ergonomic & Intelligent Design

Designed for high-volume service environments, the series features a space-saving sliding bin door mechanism that disappears into the unit’s chassis. This allows for unobstructed access to the ice reservoir even in narrow back-bar walkways. Furthermore, an integrated intelligent airflow system with frontal ventilation allows these machines to be installed flush against adjacent cabinetry, offering true “zero-clearance” capability for venues where under-counter real estate is at a premium.



KEY FEATURES

- **Crystal-clear “Bright Cube” Ice Production:** Creates premium, slow-melting ice through a high-precision spray system for superior drink presentation.
- **Intelligent Connectivity:** Equipped with Bluetooth for seamless My Ice App integration, allowing for remote status monitoring and cycle management.
- **Capacitive Touch Control:** A sleek, modern interface featuring programmable production cycles and integrated scheduling.
- **Premium AISI 441 Construction:** High-grade stainless steel build with modern rounded corners for superior durability.
- **Integrated Automatic Cleaning:** Features a dedicated sanitisation programme to maintain the highest hygiene standards with minimal manual intervention.
- **Frontal Ventilation:** Specifically designed for built-in applications, allowing the unit to be seamlessly integrated into bars where space is at a premium.
- **USB Service Port:** Provides easy access for technicians to monitor performance data and perform essential software updates.

TECHNICAL & OPERATIONAL FEATURES

- **Precision Production System:** Utilises a high-precision spray system to produce fully formed, crystal-clear ‘Bright Cubes’ with rounded surfaces for a prolonged melt rate.
- **Capacitive Touch Interface:** Features a sleek, modern touch control panel for intuitive management of programmable production cycles and integrated scheduling.
- **Intelligent Connectivity:** Equipped with Bluetooth as standard for seamless integration with the My Ice App, allowing remote monitoring of machine status and production management.
- **Advanced Sensor Array:** Incorporates precision electronic sensors for the bin, evaporator, and condenser to maintain consistent ice production and protect core components.
- **Premium Construction:** Built with high-grade AISI 441 stainless steel and modern rounded corners for superior durability and high-end aesthetics.
- **Eco-Friendly Performance:** Charged with R290 hydrocarbon refrigerant, delivering up to 25% energy savings compared to previous generations.

INSTALLATION & MAINTENANCE

- **Built-In Optimised Design:** Features frontal ventilation specifically engineered to allow the unit to be built into custom cabinetry where space is at a premium.
- **Integrated Automatic Cleaning:** Includes a dedicated sanitisation programme to maintain high hygiene standards with minimal manual intervention.
- **Front-Access Maintenance:** Equipped with an extractable front-facing air filter for easy routine cleaning to ensure the machine operates at peak efficiency.
- **Hygienic Design:** Engineered with rounded internal and external corners to eliminate “dirt traps,” simplifying food-safety compliance.
- **Plug & Play:** Supplied with a 1.85m lead and moulded UK 13A plug for immediate installation.
- **USB Service Port:** Provides easy access for technicians to monitor performance data, view service history, and perform software updates.
- **Optional Ozone Sanitisation:** Eligible for an optional kit that automatically eliminates bacteria and viruses to ensure ice safety.

SPECIFICATION PB50A

DIMENSION & WEIGHT DATA

External dimensions (W x D x H mm)	500 x 580 x 690
Packaged dimensions (W x D x H mm)	560 x 600 x 850
Net weight	38 kg
Gross weight	47 kg

PRODUCTION & STORAGE DATA

Production kg/24h @ 10°C air & water temperatures	46 kg
Pieces per cycle	28
Ice weight	20 g
Storage capacity	15 kg / 750 pcs

ELECTRICAL & WATER DATA

Voltage	220-240/50/1N
Total power	480 W
Fuse	13 A
kWh/100kg	27.9 kWh
Litres per hour	3.8 litres

REFRIGERANT DATA

Refrigerant	R290
Refrigerant charge	70g
Heat expelled	1537 W
Air volume	185 m ³ /h
Compressor Wattage	1054 W
COP	2.2

OPERATING REQUIREMENTS

Ambient temperature range	10°C to 40°C
Water temperature range	5°C to 35°C
Water pressure	1 Bar (14 psi) to 10 Bar (140 psi)
Water conductivity	20µS to 500µS (Microsiemens)

Ice Production kg/24h

Air Temp.	Water Temperature			
	10°C	15°C	21°C	32°C
10°C	46kg	45kg	41kg	32kg
21°C	39kg	38kg	34kg	28kg
32°C	37kg	36kg	32kg	26kg
38°C	35kg	34kg	30kg	22kg

Standard Features



Front Venting



Hydrocarbon Refrigerant



Crystal Clear Ice Cubes



Automatic Cleaning



Capacitive Touch



AISI441 Stainless



USB Connectivity



App Ready

Optional Features¹



Extended Feet



Ozone Sanitisation



Drain Pump



WiFi Connectivity



RTC Nano-Tech Evaporator



Water Cooled Condenser

Dimensional Drawings

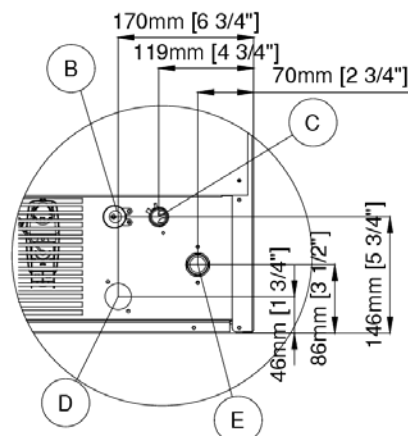
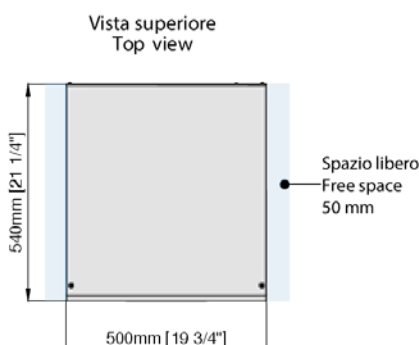
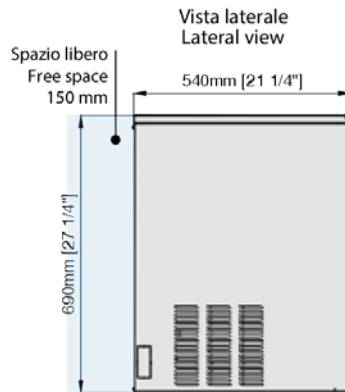
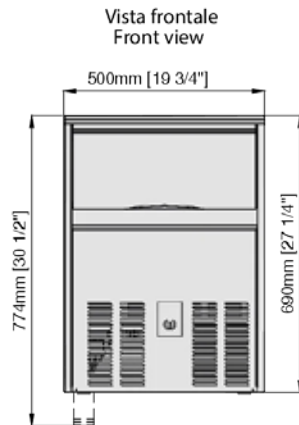

- B** Electrical cable supply
Ingresso alimentazione elettrica
- C** Water outlet connection
Attacco scarico acqua Ø 20 mm
- D** Water outlet connection
water condensation / Uscita acqua condensatore ad acqua Ø 20 mm
- E** Water inlet connection / Attacco entrata acqua - 3/4" G



Kit 4 Feet
Kit 4 piedini
Ø50mm H100-120 mm

(Opzionali-optional)

