



DISHWASHER UX-120SBCDV 230/50/1

Rack size 500x500mm and door clearance 440 mm. Double-skinned hood.

P/N 1303422



WARE WASHING
PASS-THROUGH DISHWASHERS

SALES DESCRIPTION

Sani-Control: guaranteed disinfection
Double-walled hood: insulation and energy efficiency
Exclusive Hydroblade™ washing arms: maximum effectiveness.
3-stage filtering system.
Steam condenser: environmental improvement and energy efficiency.

Sani-Control guarantee

- ✓ GUARANTEED DISINFECTION in compliance with standard DIN 10534.
- ✓ THERMAL LOCK function: Ensures that rinsing will be carried out at the ideal temperature to disinfect the dishes.
- ✓ CONSTANT HIGH TEMPERATURE RINSE system for optimal disinfection.
- ✓ The PRESSURE PUMP guarantees effective high-pressure rinsing
- ✓ WRAS certified.

Steam condenser

- ✓ Reduces the steam released into the installation by 75%.
- ✓ Factory-integrated condenser module, no installation required.

New recessed bodywork

- ✓ Ergonomic design with rounded corners to prevent the accumulation of dirt and facilitate cleaning.
- ✓ Compact tank volume (50% water saving compared to the previous range).

Double-Walled (Ultra ISO)

- ✓ Double-Walled Structure: thermo-acoustic insulation to attenuate the sound level and improve energy efficiency

Hydroblade™ washing arms

- ✓ Redesigned nozzles for greater washing performance.
- ✓ The “monoblock” design delivers durability and resistance to impacts.

- ✓ 30% savings in water consumption during rinsing compared to the previous range.

3-stage filter system: surface, tank and extraction

- ✓ Keeps the washing water in optimal conditions to maintain constant washing performance.

Designed to last

- ✓ “Flow” opening mechanism: allows the hood to be raised with less effort
- ✓ High load capacity 44 cm: suitable for GN 1/1 and Euronorm
- ✓ Stainless steel surface filters for greater stability and resistance during intensive use

Premium warewashing

- ✓ Soft start: progressive start-up of the washing pump to protect fragile items.
- ✓ Colour LCD Display: intuitive communication of the machine status by means of messages, colour codes and icons.
- ✓ Dedicated cycles: selection of the ideal washing programme using icons.
- ✓ Adaptable: allows the main parameters of the machine to be adjusted to the needs of each user.
- ✓ TEMPERATURE DISPLAY
- ✓ Wash Plus+ function: increases the intensity of the wash cycle for greater cleaning performance
- ✓ Control panel with IP65 humidity protection.

You will never WASH ALONE

- ✓ Tech-Services: our team of technicians will help you so that your machine is always ready for use.
- ✓ Design Services: tell us what your needs are and we will advise you.
- ✓ 60 years of experience and know-how at your disposal.

INCLUDES

- ✓ Detergent Dispenser. detector.
- ✓ Drainage pump with level sensor. Proactive tank water renewal.
- ✓ Automatic resin regeneration water softener with salt
- ✓ Rinse aid pump.
- ✓ 1 glasses basket.
- ✓ 1 mixed basket (plates).
- ✓ 1 cutlery basket.

OPTIONAL

□ .

ACCESSORIES

- Tables for dishwashers P/X/S (pass-through model)
- Manual water softeners
- Automatic water softeners
- 500 x 500 mm. baskets
- Inserts & supplements
- Central sorting tables
- Double connection central sorting table
- Prewashing tables for pass-through and rack conveyor dishwashers
- Connecting tables for Pass-Through dishwashers and rack conveyors
- Reverse Osmosis device OS-140P

SPECIFICATIONS

Basket dimensions: 500 mm x 500 mm
 Maximum glass height: 430 mm
 Cycles: 6
 Cycle duration: 60/90/100/150/210 “
 Production baskets/hour: --
 Boiler capacity: 12 l





DISHWASHER UX-120BCDV 230/50/1

Rack size 500x500mm and door clearance 440 mm. Double-skinned hood.



P/N 1303422

Wash tank capacity: 25 l

Consumption and savings

- ✓ Water consumption/cycle: 2.8 l
- ✓ Automatic saving mode in: 25 '
- ✓ Automatic switch-off: 120 '

Loading

Pump: 1000 W / 1.3 Hp

Tank: -- W

Boiler: 9000 W

Total loading: 9000 W

Electrical supply: -- V / -- Hz / -- ~ (-- A)

- ✓ Width: 650 mm (: -- mm)
- ✓ Depth: 755 mm (: -- mm)
- ✓ Height: 2035 mm / 2035 mm

Net weight: 161 Kg

Wash temperature: -- °C

Rinse temperature: 87 °C

Net weight: 161 Kg

Noise level (1m.): <70 dB(A)

Crated dimensions

760 x 860 x 2050 mm

Gross weight: 172 Kg

External dimensions (WxDxH)

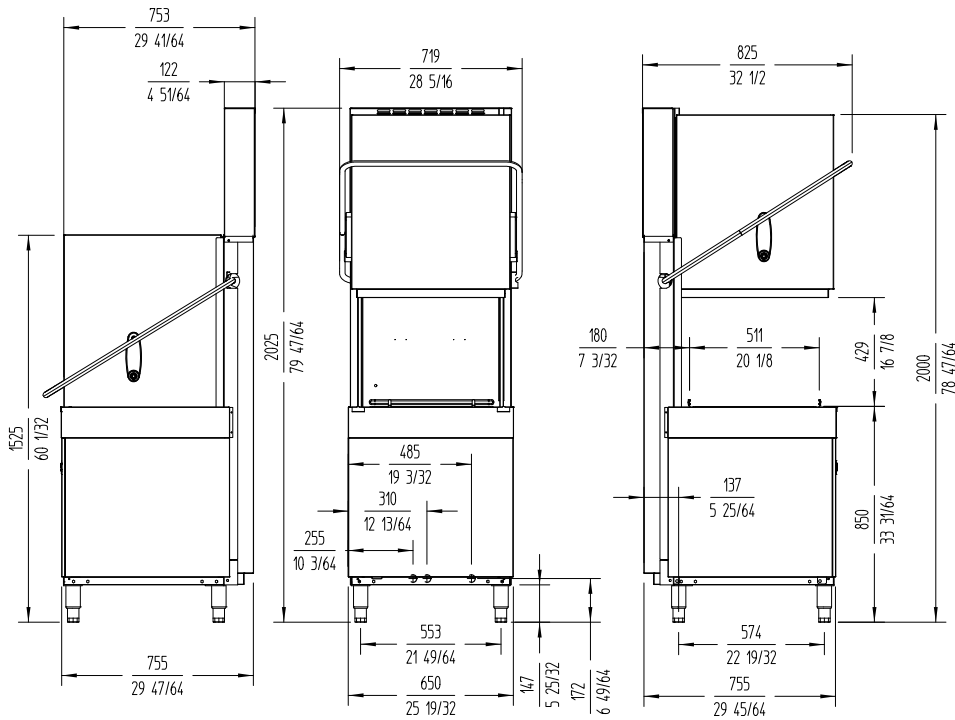

WARE WASHING
PASS-THROUGH DISHWASHERS



www.sammic.co.uk

Food Service Equipment Manufacturer

Unit 2, Trevanth Road

Troon Industrial Park

LE4 9LS - Leicester

uksales@sammic.com

Tel.: +44 0116 246 1900



Project

Date

Item

Qty

Approved

product sheet
updated 17/02/2022